

AN ABSTRACT OF THE DISSERTATION OF

Karen E. Bledsoe for the degree of Doctor of Philosophy in Science Education presented on March 16, 2007.

Title: How Do Engineering Students Develop and Reason With Concepts of Electricity Within a Project-Based Course?

Abstract approved: _____
Lawrence B. Flick

Reform in science education has often emphasized task-based learning as an instructional method to improve student understanding and retention of concepts, and to promote the development of reasoning and problem-solving. Yet studies assessing student knowledge at the beginning and end of a task-based class show mixed results. Students in task-based science and technology courses may gain greater long-term retention of knowledge than their traditional counterparts, though immediate gains may be comparable. Curriculum developers and educators express concerns that the costs of developing and implementing task-based instruction may not justify the results. Yet the question of whether students learn more in a task-based setting than a traditional setting is difficult to answer without fully understanding how students learn in a task-based context. Toward this end, this study presents a tentative model of learning in task-based contexts.

A phenomenological perspective was employed to examine conceptions held by first-year undergraduate electrical engineering students around current, voltage, and resistance in simple and complex circuits. The study also examined how the students' prior knowledge interacted with their reasoning skills as these students engaged in a project based laboratory component of an introductory electrical engineering course. Students entering the course with low prior knowledge and high prior knowledge were selected for

the study. Seven volunteered as participants and completed the study. Three were assessed as having low prior knowledge of electrical concepts, and four had high prior knowledge.

Subjects were interviewed near the beginning and after the end of an electrical engineering course that included a project-based laboratory. Interviews were analyzed for subject content knowledge. The subjects were observed performing in lab as they carried out various tasks using TekBots™ robotic kits. Dialogue between the subjects and others in the lab, including the researcher, was analyzed for evidence of reasoning skills and how the subjects used their knowledge and mental constructions when engaged in problem-solving.

Subjects displayed a wide range of conceptions, including alternative conceptions and conceptions that matched the target concepts as presented in the lecture section. As expected, students entering with low prior knowledge had many alternative conceptions and undeveloped ideas about electricity. Reasoning skills in lab were analyzed using a hierarchy presented by Driver et al. (1996). Subject reasoning ability, from phenomenon-based at the lowest to model-based at the highest, related less to prior knowledge of electrical concepts than it did to prior experience in mathematics classes. Thus one of the subjects who entered the class with little prior knowledge but high ability in mathematics was able to complete the tasks successfully, while another subject with high prior knowledge but low ability in math struggled through each of the tasks. These findings were used to refine a model of task-based learning that describes student knowledge and other factors brought to a task, the interaction between meaningful knowledge (that which is used spontaneously) and inert knowledge (that which is known, but is not

applied spontaneously to the task), and questions how inert learning is activated to become meaningful.

©Copyright by Karen E. Bledsoe
March 16, 2007
All Rights Reserved

How Do Engineering Students Develop and Reason With
Concepts of Electricity Within a Project-Based Course?

by

Karen E. Bledsoe

A Dissertation

submitted to

Oregon State University

in partial fulfillment of
the requirements for the
degree of

Doctor of Philosophy

Presented March 16, 2007
Commencement June 2007

Doctor of Philosophy dissertation of Karen E. Bledsoe presented on March 16, 2007.

APPROVED:

Dr. Lawrence Flick, representing Science and Mathematics Education

Dr. Lawrence Flick, of the Science and Mathematics Education Department

Dean of Graduate School

I understand that my dissertation will become part of the permanent collection of Oregon State University libraries. My signature below authorizes release of my thesis to any reader upon request.

Karen E. Bledsoe, Author

ACKNOWLEDGEMENTS

The author expresses sincere appreciation to those who have made all this possible: to Dr. Larry Flick, my major professor; to Roger Traylor, the ECE instructor who put up with me for an entire term; to my research subjects, without whom this would not have been possible; to my committee members, which included Dr. Larry Enochs, Dr. Shawn Rowe, Dr. Mark Wilson, and Dr. Barbara Taylor; to Dr. Edith Gummer, for early guidance on assessment and qualitative research; to Dr. Nam Hwa Kang, for a last-hour rescue; to Dr. Emily van Zee and the students of her graduate seminars who contributed to some of the early data analysis; to Dr. Maggie Niess for endless encouragement and opportunities for employment; to the graduate students of the Science and Mathematics Education Department who have heard bits and pieces of this project for quite some time; to Dr. SueAnn Bottoms, for being there; and finally but not least of all, to my family, especially my husband Glen and my son James, for their endless encouragement and support.

TABLE OF CONTENTS

	<u>Page</u>
Chapter 1: Introduction	1
Task-based learning	1
Problem statement.....	4
Electrical and Computer Engineering and the TekBots Program.....	6
A proposed model of task-based learning.....	7
Purpose of the research	13
Significance of the Study.....	13
Chapter 2: Review of the Literature.....	16
Introduction.....	16
Student conceptual change within task-based learning	17
Concept development.....	17
Transfer of concepts.....	33
Emergent factors	39
Student reasoning within task-based learning.....	41
Development of hypothetico-deductive reasoning	41
Model-based reasoning	61
Transfer of reasoning skills.....	68
Emergent factors	73
Metacognitive skills.....	75
Emergent factors	81
Student concepts about electricity	82
Energy.....	82
Electrical current.....	92
Concepts of current.....	93
Current in simple circuits.....	98
Models for more complex circuits	102
Voltages in circuits	105
Emergent factors	107
Chapter 3: Design and Method	109
Design of the Study.....	109
Context: TekBots™ program model.....	109
Context: ECE 112 course description.....	111
Participants.....	112
Theoretical framework.....	114
Phenomenology as a research perspective	114
Phenomenography as a research tool.....	116
Identifying cognitive effects	119
Conceptual change	119
Reasoning strategies.....	122

TABLE OF CONTENTS (Continued)

	<u>Page</u>
Method	127
Data collection	130
Phase I: Participant selection	130
Phase II: Describing student’s initial concepts and reasoning.....	133
Phase III: Observing dynamics of change	136
Qualitative analysis of data.....	139
Constructed categories of knowledge	139
Analysis of use of knowledge during reasoning: concept mapping	141
Analysis of student reasoning	148
Chapter 4: Results	151
Introduction.....	151
Constructed Categories of Knowledge	152
Primary concept: nature and function of batteries	153
Battery is a repository of current	154
Battery is a voltage source	155
Battery supplies voltage which causes current	156
Primary concept: Nature and function of light bulbs.....	158
Light is the result of a chemical reaction between electricity and chemicals in the bulb.	158
Light is the result of a conversion of electrical energy to light (and heat) energy.	159
Primary concept: the nature of current.....	161
Current is material or quasi-material	162
Current is energy.....	164
Primary concept: Voltage	165
No concept of voltage	167
Voltage is current or is like current.....	168
Voltage is a measure of strength, size, or force of current	169
Voltage is pressure or “push”	170
Voltage is potential energy	172
Primary concept: Resistance	175
Resistance is holding back current.....	177
Resistance is a restriction of current flow.....	179
Resistance is the dissipation of energy	180
Models of Circuits.....	182
Simple, series, and parallel circuits.....	183
Linear model	185
Circular sequential model	186
Transitional	192
Non-sequential interrelational model.....	199
Branching circuits	203
Brightness should change because one bulb gets both batteries.....	204
Brightness should not change because the switch creates two independent circuits	206

TABLE OF CONTENTS (Continued)

	<u>Page</u>
Brightness should not change because there is essentially no current across the switch	208
Summary	210
Subject Use of Knowledge During Reasoning	213
Subject AM	214
Subject YZ	222
Subject MJ	230
Subject KR	241
Subject JF	251
Subject AK	260
Subject TA	269
Summary	280
Quality of Student Reasoning	285
Subject AM	285
Subject YZ	287
Subject MJ	289
Subject KR	292
Subject JF	294
Subject AK	296
Subject TA	298
Summary	299
Chapter 5: Discussion and Limitations	301
Introduction	301
Guiding and Emergent Themes	302
Phenomenological categories of knowledge	302
Batteries	303
Bulbs	305
Current	306
Voltage	308
Resistance	310
Models of circuits	311
Branching circuits	313
Factors related to student reasoning	315
Meaningful learning	318
Revised model of task-based learning	321
Implications for future research	326
Limitations	327
References	332
Appendix: Electrical Concepts Inventory	338

LIST OF FIGURES

<u>Figure</u>	<u>Page</u>
1. A diagram of learning based on Whitehead's (1929) concepts of inert and meaningful learning.	8
2. A proposed model of learning within task-based curricula, based primarily on Whitehead (1929) and Bransford, et al. (1993).	9
3: Osborne and Freyberg's (1985) models of current in simple circuits. A. Unipolar, B. Clashing Currents, C. Attenuation, D. Scientific. Shipstone (1984, 1985) adds a fifth model, a Sharing model, which applies to circuits with several bulbs or other components connected in series.	94
4. The Doll's House task, adapted from a diagram in Duit (1985). In the task, subjects were asked to make bulbs A and B light up simultaneously when one switch was flipped, and C light up separately when the second switch was flipped.....	104
5. An assembled TekBot™ robot with optional whiskers	110
6. Circuit board used in the interviews, consisting of three bulbs in holders, four resistors (two 1 ohm resistors and two 4.7 ohm resistors), a brass switch, and two battery packs.	134
7. Diagram of the arrangement of elements on the circuit board used in the interviews.	135
8. Diagram shown in problem 6 on the survey form, which proved problematic for most students.....	203
9. Concept map for AM, initial interview.....	215
10. Concept map for AM, Observation 2.....	217
11. Concept Map for AM, exit interview.....	220
12. Concept map for YZ, initial interview	223
13. Concept map for YZ, Observation 2.....	225

LIST OF FIGURES (Continued)

<u>Figure</u>	<u>Page</u>
14. Concept map for YZ, Observation 3.....	226
15. Concept map of YZ, exit interview.....	228
16. Concept map for MJ, initial interview	231
17. Concept map for MJ, Observation 1	234
18. Concept map for MJ, Observation 2.....	235
19. Concept map for MJ, Observation 3.....	237
20. Concept map for MJ, exit interview	239
21. Concept map for KR, initial interview.....	242
22. Concept map for KR, Observation 1.....	244
23. Concept map of KR, Observation 2.....	246
24. Concept map for KR, exit interview.....	249
25. Concept map for JF, initial interview.	252
26. Concept map of JF, first observation	254
27.: Concept map for JF, second observation.....	256
28. Concept map for JF, exit interview.....	258
29. Concept map for AK, initial interview	260
30. Concept map for AK, Observation 1	263
31. Concept map for AK, Observation 2	265
32. Concept map for AK, exit interview.....	268
33. Concept map for TA, initial interview.....	270
34. Concept map for TA, Observation 2.....	273
35. Concept map for TA, Observation 3.....	276

LIST OF FIGURES (Continued)

<u>Figure</u>	<u>Page</u>
36. Concept map for TA, exit interview	278
37. Schematics from Section 2 of the ECE 112 lab manual for an exercise in measuring current directly and indirectly.	320
38. Revised model of task-based learning	322

LIST OF TABLES

<u>Figure</u>	<u>Page</u>
1. Topics and concepts covered during the lecture and lab portions of ECE 112.	113
2. Typology of characteristics of student epistemological reasoning about scientific concepts. Adapted from Driver et al., 1996.	126
3. Subjects selected for the study, identified by initials, their gender, stated ethnicity, prior coursework in which they recalled learning electrical concepts, prior experience in working with electrical systems or electronics, and the score on the survey out of a possible 24.	132
4. Relationship between emergent themes and data sources.	139
5. Distribution of student concepts across the conceptual categories of knowledge around the nature and function of batteries. Full explanation of the categories is in the text. "1" indicates the initial interview, "2" the final interview.	157
6. Distribution of student concepts across the conceptual categories of knowledge around the nature and function of light bulbs. Full explanation of the categories is in the text. "1" indicates the initial interview, "2" the final interview.	160
7. Distribution of student concepts across the conceptual categories of knowledge around current. Full explanation of the categories is in the text. "1" indicates the initial interview, "2" the final interview.	165
8. Distribution of student concepts across the conceptual categories of knowledge around voltage. Full explanation of the categories is in the text. "1" indicates the initial interview, "2" the final interview.	175
9.: Distribution of student concepts across the conceptual categories of knowledge around resistance. Full explanation of the categories is in the text. "1" indicates the initial interview, "2" the final interview.	182

LIST OF TABLES (Continued)

<u>Figure</u>	<u>Page</u>
10. Distribution of student models around simple circuits. Full explanation of the categories is in the text. “1” indicates the initial interview, “2” the final interview. Subject MJ is shown as having two initial models because the linear model showed up on her survey form, but she had discarded it for a circular sequential model by the time of the first interview.....	202
11. Distribution of student models around branching circuits. Full explanation of the categories is in the text. “1” indicates the initial interview, “2” the final interview.....	210
12. Summary of AM’s knowledge about the target electrical concepts (circuits, voltage, current, resistance) across the term.	221
13. Summary of YZ’s knowledge about the target electrical concepts (circuits, voltage, current, resistance) across the term.	230
14. Summary of MJ’s knowledge about the target electrical concepts (circuits, voltage, current, resistance) across the term.	240
15. Summary of KR’s knowledge about the target electrical concepts (circuits, voltage, current, resistance) across the term.	251
16. Summary of JF’s knowledge about the target electrical concepts (circuits, voltage, current, resistance) across the term.	259
17. Summary of AK’s knowledge about the target electrical concepts (circuits, voltage, current, resistance) across the term.	269
18. Summary of TA’s knowledge about the target electrical concepts (circuits, voltage, current, resistance) across the term.	280
19. Summary of the reasoning employed by subjects during lab activities.....	300
20. Summary of level of reasoning related to mathematical experience and prior knowledge among the seven subjects.....	317
21. Summary of success at lab tasks related to math ability and prior knowledge among the seven subjects.....	318

How Do Engineering Students Develop and Reason With Concepts of Electricity Within a Project-Based Course?

Chapter 1: Introduction

Students at all educational levels possess a wide range of mental constructs relating to natural phenomena (Wandersee, Mintzes, & Novak, 1994). Even college students who begin a course of study in their chosen major may arrive with alternative conceptions regarding the subject in which they are interested. For example, first-year chemical engineering students often possess conceptions regarding energy (Ebenezer & Fraser, 2001; Liu, Ebenezer, & Fraser, 2002) that appear inconsistent with scientific models and resemble naive conceptions held by younger students and non-engineering majors (Watts, 1983). Reasoning ability among students of the natural sciences can also vary widely, and can affect students' ability to move from alternative conceptions to scientifically-acceptable conceptions (Westbrook, et al., 1990; Lawson, et al., 1993).

A number of teaching strategies have been developed to address student alternative conceptions, to facilitate conceptual change in the direction of scientific concepts, and to promote reasoning skills. Among these strategies are task-based curricula.

Task-based learning

Task-structured curricula are those that are organized not as a systematic progression through content topics, but rather are anchored in a task, problem, or goal, requiring

students to learn in and reason across multiple traditional content areas. Students move through a task rather than a conceptual space. Much of task-structured learning takes place within a social context, which appears to be important in fostering conceptual change. Change is more likely when students are required to reveal, explain, elaborate, and defend their positions and ideas within a group. Revision occurs as students articulate their ideas, and conflict with other students produces dissatisfaction with their ideas (Petrosino, 1998; Sherin, 2004). Learning is enhanced when students struggle with problems, mastering concepts along the way, rather than learning concepts in a rote fashion and then applying the information to sample problems (Norman & Schmidt, 1992). As students apply new knowledge, however, they do not always apply it well. In studies on medical students engaging in task-based learning, student explanations were both more elaborate and more error-prone (Patel, et al., 1986; 1990; 1991).

Problem-based learning (PBL), one form of task-based learning, has been widely applied in professional training in medicine, law, engineering, and business. Learning through problem-solving serves as a cognitive apprenticeship in professional fields. Medical expertise, for example, develops gradually as students learn and apply content knowledge to clinical settings. PBL is used to integrate science knowledge and clinical knowledge to develop clinical reasoning skills (Barrows & Tamblyn, 1980).

PBL fosters hypothesis-driven learning and active learning strategies, both of which depend on prior knowledge within a wide range of curricular topics, and require the use of generic problem-solving skills. One drawback is that PBL undertaken with weak prior knowledge can lead to inappropriate application of new knowledge that is poorly

understood. In contrast, during content-driven learning, students make generalizations from many examples, requiring the use of strong (content-specific) problem-solving skills that can lead to poor knowledge as to how the content should be applied in real-world problems, as well as poor learning transfer. Content-driven learning does not require deep analysis, and can result in irrelevant correlations and incorrect assumptions. (Petrosino, 1998; Weidner, 2000; Sherin, 2004)

A large body of research exists on PBL within medical curricula; indeed, PBL as it is usually defined in educational research literature began in medical education. Most of the research, however, focuses on outcomes: primarily test scores, but also student and instructor attitudes toward the task-based curricular structure. Only a small portion of the literature examines student cognitive processes and conceptual change within the context of problem-based learning. Much of the cognitive research that has been reported was carried out with undergraduate and graduate medical, legal, and business students who can be expected to have extensive prior knowledge on which they can draw when solving problems. Much less is known about how students with a weak knowledge base reason and learn within PBL courses.

Cognitive research suggests that students draw on their knowledge base when solving problems, and that a strong knowledge base relates to successful problem-solving (Anderson, 1987). K-12 students and college undergraduates enrolled in classes outside of their majors may lack a sufficient knowledge base to successfully engage in the hypothesis-driven learning that is an integral part of problem-based curricula.

Problem statement

Task-structured curricula are anchored in a task, problem, or project, requiring students to operate and reason across content areas, rather than work through a predetermined series of content topics. The utility of task-structured curricula has been the subject of a great deal of research, most of which has come to ambiguous conclusions (Albanese & Mitchell, 1993). On tests of content knowledge, students taught in the traditional manner often have a slight advantage over those taught in a task-based manner (for example, Saunders, et. al, 1990), though in many studies comparing task-based and non-task-based curricula, the test score differences between the two groups are insignificant (for example, Enarson & Cariaga-Lo, 2001). However, students who learned their content in the context of a task may retain that knowledge longer (Breton, 1999), or be better at applying the content to a real-world problem (Vernon & Blake, 1993). In many settings, most notably in medical education, problem-based learning is viewed as a cognitive apprenticeship to the medical profession, training students to solve clinical problems before they enter the clinical setting. For students, however, the real gateway to the medical profession is a professional examination of medical content knowledge, and if they feel that problem-based learning puts them at a disadvantage on the exam, they may resist and resent engaging in problem-based learning (Enarson & Cariaga-Lo, 2001).

The inconclusive results of studies on the outcomes of task-based learning, and possible negative consequences, have not prevented reform efforts from promoting problem-based and project-based learning as ideal methods to help children learn science concepts. Because there can be high costs involved in implementing task-based curricula,

including monetary costs and the investment of time, instructors may want to know whether the methods are truly advantageous, or if the methods are, as critics may claim, actually harmful.

The results of these studies also leads some researchers to believe that, “Does task-based learning improve test scores?” is the wrong question to ask — or at least is overly-simplistic. Task-based learning is a very different way of learning from traditional lecture-practice-test teaching, and creates different cognitive demands. Students who engage in problem-based learning often do better than traditional students on tests that involve problem-solving, which is to be expected since problem-solving was a part of the daily experience of problem-based learning students (Hmelo, 1998).

That students engaged in task-based learning may be thinking, reasoning, and experiencing conceptual change differently than students in other learning contexts seems a reasonable hypothesis. Capturing these differences is often difficult, as conceptual models and reasoning skills require more than a survey or standardized test to measure. Furthermore, any discussion of generic “students” is oversimplified. Students enter a task-based course with a wide range of prior knowledge in the various content areas needed to complete the task. They often have to work in groups where their collective knowledge is of greater importance than their individual knowledge, and may, through the group, achieve tasks of greater complexity than each member could achieve individually.

A better question to ask, then, may be, “How do students learn within task-based contexts?” More specifically, “How do students learn content knowledge and reason with

content knowledge within a task-based setting?” Answering this question creates a rich description of student learning, mental representations, conceptual change, and reasoning that occurs as students struggle with solving problems or completing tasks, as well as the dynamics involved in the social construction of knowledge. The results of many studies around these questions may then be compared with studies involving similar questions about students learning by didactic methods.

Electrical and Computer Engineering and the TekBots Program

Electrical and Computer Engineering (ECE) students, like all students, enter a program of study with a wide range of prior knowledge in all subjects, including the subject in which they intend to major. A project-based electrical engineering course requires students to apply their knowledge of electricity, electronics, and problem-solving in order to complete a set of engineering tasks. A reasonable assumption might be that the more a student knows about electrical concepts, the better and more facile that student will be at completing the required projects, and the better that student will be able to troubleshoot problems while working on the project.

On the Oregon State University campus, beginning ECE students enroll in ECE 112: Introduction to Electrical and Computer Engineering during winter term. The laboratory portion of this course is project-based, with students working with a TekBots™ robot kit, which the students purchase. Labs are designed around assembling the basic robot platform and making it work. Problem-solving in the form of troubleshooting is an inherent part of the lab exercise as students often find that their first attempts at

assembling a working system fail even when the lab includes detailed assembly instructions.

Success in the laboratory requires a combination of physical skills (such as soldering and manipulating small electrical components), applying electrical concepts (such as concepts about circuits, current, voltage, and resistance), and applied problem-solving (diagnosing a problem and finding a solution). It might be predicted that students with a strong knowledge of electrical concepts and prior experience in working with microelectronics would have an advantage on the laboratory tasks. Conversely, students with poor knowledge or lack of prior experience might be handicapped, and thus would encounter more difficulties as they attempt to complete the lab. This study will examine students at these two extremes of knowledge and experience, and document how they assimilate new information, reason within the task-based environment, and apply their knowledge to the task.

A proposed model of task-based learning

Bransford, et al. (1993), in developing a description of problem-based learning, cited a model proposed by Whitehead (1929) In Whitehead's model (Figure 1) knowledge that a student brings to a task consists of prior knowledge related to the subject and direct instruction regarding the task. What emerges is a separation of inert from meaningful learning. Whitehead defined "meaningful learning" as that which the individual values and uses spontaneously in daily life, as opposed to "inert knowledge," which may be recalled when asked for, such as on an exam or in an interview, but is not used

spontaneously. Applied to task-based learning, meaningful learning would be that which a student spontaneously applies to a task, while inert learning would be that which a student may recall on an exam.

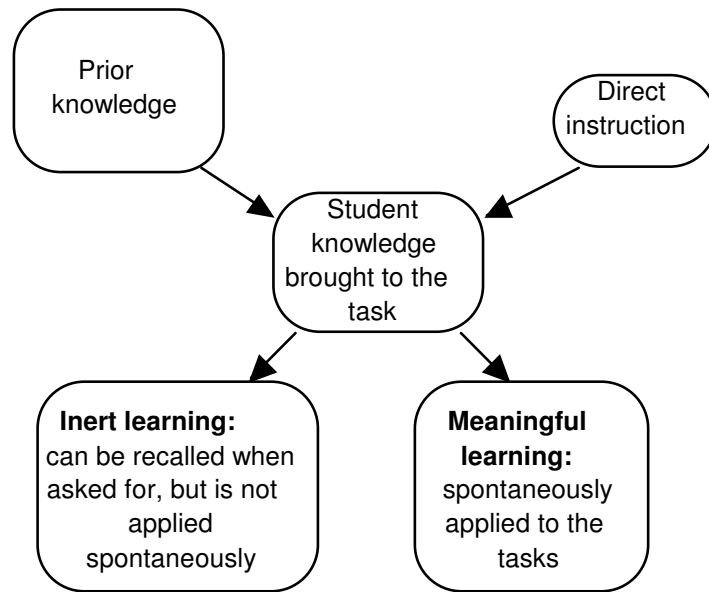

Figure 1: A diagram of learning based on Whitehead's (1929) concepts of inert and meaningful learning.

Bransford, et al., in discussing Whitehead's propositions in the context of the acquisition and transfer of knowledge during anchored instruction, argued that task-based instruction is more likely than didactic instruction to result in the acquisition of meaningful knowledge, stating, "...knowledge is less likely to remain inert when it is acquired in a problem-solving mode rather than in a factual-knowledge mode" (Bransford, et al., 1993, p. 116). Bransford proposed that meaningful learning applied to tasks is retained, and may be applied to further tasks. The implication is that the body of

meaningful knowledge will grow through practiced problem-solving, and that the problem-solving context fosters the transfer of knowledge to new problems.

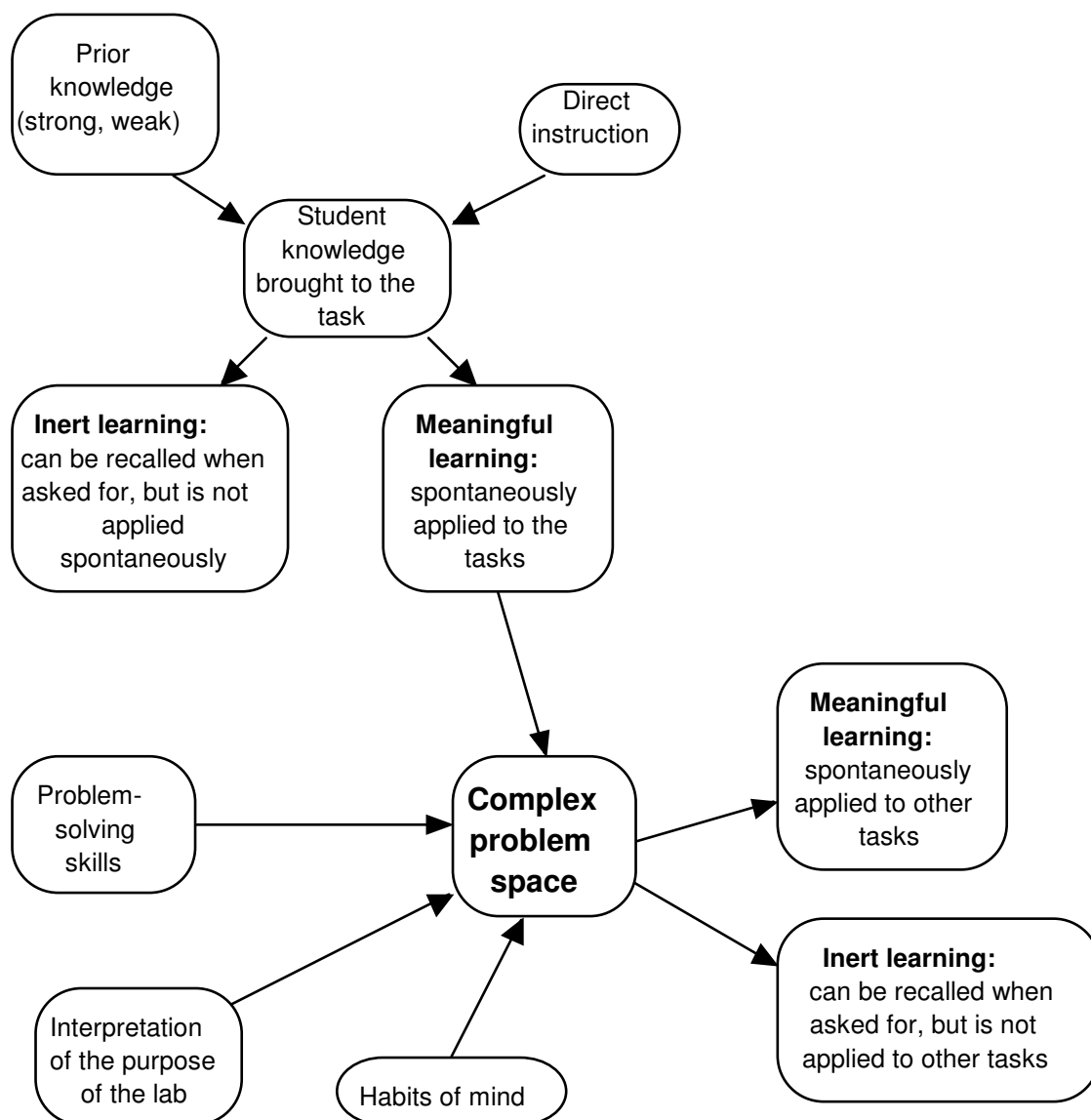

Figure 2: A proposed model of learning within task-based curricula, based primarily on Whitehead (1929) and Bransford, et al. (1993).

Both Whitehead's original model and elaborations argued by Bransford et al. are incorporated into the model in Figure 2. This model proposes that meaningful knowledge may be discerned in two instances when students learn new concepts and are asked to apply their knowledge to a task. The first occurs as students enter the problem space. Students bring with them a complex array of knowledge, beginning with their prior knowledge upon entering a course. This prior knowledge may be strong or weak in the area of the phenomenon to be grappled with in the task. As noted earlier, strong prior knowledge of a phenomenon is strongly related to successful problem-solving (Anderson, 1987). In addition, students may learn new knowledge in a class setting before approaching the problem, depending on how the curricular tasks are arranged.

The knowledge that students apply directly to the task can be identified here as "meaningful learning." This is knowledge that students use without being prompted to do so. "Inert learning" is that learning that students have acquired and may be able to reproduce on a test, but that does not appear during problem-solving or is not applied to other tasks unless students are prompted to do so by an instructor. The selection of knowledge by the student reflects student values regarding that knowledge, and may also reflect a student's understanding of how the knowledge relates to the task.

This model also proposes that entering the complex problem space are a number of other factors. Besides knowledge, students bring a set of problem-solving skills. While this may be considered a type of knowledge, here it is separated so as to distinguish knowledge of problem-solving from knowledge of content. The students' individual interpretations of the purpose of the activity may affect how the student approaches the

task. For example, in a study described by Osborne & Freyberg (1985), students who correctly interpreted a laboratory task as creating an electrical device to test the conductivity of different substances approached the task differently from the students who believed the task was about getting a light bulb to light up every time. The latter misinterpretation led a pair of students to create a circuit with a short in it that lit every time the switch was pressed, regardless of what material was being “tested” for conductivity.

Students also bring their habits of mind to the task. Here “habits of mind” is a broad category that includes thinking skills, the willingness to see a task through, the willingness to ask for help, any tendencies to depend upon others, and a student’s self-efficacy toward learning the subject matter. Habits of mind may influence how students approach a task and whether a student will give up or press on when faced with a difficult problem. Though habits of mind were not operationalized and examined directly in this study, they were included in this model as a factor that may be of importance. Data that were collected during the study did include indirect support of the probable importance of this category of factors, and suggest that this category may need to be unpacked and examined further.

The complex learning space constitutes another learning environment in which students not only apply knowledge, but construct new knowledge. What emerges from working with the task will be the student’s knowledge, now transformed. There will again be meaningful learning, which is spontaneously applied to other tasks. There will also be inert learning, which will not be applied to future tasks but can be recalled if a

student is asked to recall it, as on an exam. These knowledge sets are not necessarily the same as those that went into the task. New knowledge has been added, and what was inert before may become activated through prompting, applied, and found to be valuable and meaningful. The implication, however, is that both bodies of knowledge will increase with each opportunity to engage in task-based learning.

These last boxes on the model should not be interpreted as terminal points; rather, the model diagrams an iterative process. Meaningful learning that emerges from the complex problem space will be applied to the next problem, which in turn will result in new meaningful and inert learning in a process that may continue throughout a person's lifetime.

At some point, doubtless, some portion of the inert learning may be activated and become meaningful learning, perhaps through further instruction to reinforce the knowledge, or by a learner's spontaneous connection between a current problem and recollection of old knowledge. This process was not been added to this initial model as it was outside the scope of the current study. However, data from the study suggest that this may be a critical factor in understanding the use of knowledge during task-based learning. An understanding of this process could contribute greatly to the understanding of task-based learning and to the development of effective task-based curriculum.

Purpose of the research

The purpose of this research was to contribute to a coherent description of learning in task-based settings. Out of that goal came three primary goals for that guided the development of this study:

1. To document, analyze, and trace changes in students' conceptions and reasoning for students with low prior knowledge and students with high prior knowledge while students are engaged in a project-based engineering laboratory.
2. To compare conceptual changes and reasoning between students who enter the program with strong knowledge of energy, electricity, and circuits and students who enter with weak knowledge.
3. To observe and document learning that becomes meaningful for students and changes in the body of meaningful learning throughout an electrical engineering course in order to test and refine the proposed model of task-based learning.

These goals were then operationalized as a set of guiding questions that were used in developing a set of research protocols. As the research proceeded, however, the questions changed and additional questions emerged from the data that were significant to the development of the model. These guiding questions and emergent questions will be discussed in Chapter 3.

Significance of the Study

When a course of instruction moves from a content-structured approach to one guided by a larger task or problem, students find themselves confronted by a different

slice across the content, since task-structured approaches tend to address content across a range of disciplines. Even within the more narrowly-defined task of solving problems in microelectronics, students bring to the task a wide range of knowledge, experience, and approaches to problem-solving. Controversy exists over whether a task-structured environment is better for student learning, or if it can actually handicap students and delay their understanding of concepts and development of reasoning (Albanese & Mitchell, 1993).

Neither an analysis of content of the course nor a measure of content recall at the end of the course compared with content known at the beginning is sufficient to describe how the content is understood and used by the learner. The current emphasis on standardized tests notwithstanding, meaningful learning consists not in a collection of facts that are recalled when asked for, but in the spontaneous application of that knowledge to everyday situations and tasks (Whitehead, 1929).

Producing detailed accounts of meaningful learning within a task-based context, however, is difficult, though it is vital to understanding whether these types of curricula can achieve their specific learning goals. Of particular concern is the bootstrapping problem described by Sherin, et al., (2004), who note:

Indeed, there are some very serious reasons to worry whether any particular task-structured curriculum can achieve its learning goals, and lead to rigorous content understanding. In this paper, we want to draw out and emphasize one particular reason for worry, what we call the

bootstrapping problem: How can we expect students to work on problems and issues that cut across multiple disciplines if we have not already provided them with a solid foundation in these disciplines?

This study is a contribution to the small but growing body of literature that attempts to describe the processes of student learning and reasoning within a task-based context in order to understand learning processes within these types of learning environments.

Chapter 2: Review of the Literature

Introduction

This chapter discusses the literature on conceptual change and student reasoning within task-based (TBL) learning, and current research on student concepts around energy, electricity, and electrical circuits. A synthesis of these two bodies of literature supports the case for examining how student development of electrical concepts occurs in a task-based learning context, and how student knowledge and concepts influence reasoning around electrical engineering tasks.

Anderson (1987), using a production system model of learning, states that the active application of knowledge causes the learner to develop production systems in which knowledge is encoded into more robust and longer-lasting frameworks than would be found in passive learning contexts. A reasonable assumption to draw from this statement is that TBL, as an active learning context, should produce robust conceptual development and better knowledge retention, and may in turn support better reasoning around a problem or task.

Student conceptual change within task-based learning

Concept development

One of the earliest studies to examine conceptual change during problem-based learning was a descriptive study by de Grave, et al. (1996) that looked in depth at cognitive processes during problem analysis. Because PBL is perceived as a strategy to create cognitive change, primarily through cognitive conflict that results from the disagreement between individual student knowledge and the problems the students work on, a reasonable hypothesis is that PBL should lead to measurable conceptual change, and that conceptual change should be an observable process. However, conceptual change is for the most part an intraindividual process. de Grave and others used a stimulated recall process to uncover student thinking, reasoning, and concept formation during problem-solving.

The subjects of the study were five second year medical students who were experienced in PBL, and had analyzed problems in tutorial group meetings twice a week for two years. The students were videotaped as they analyzed a problem case involving a factory worker with a painful finger, leading to a diagnosis of an uncommon disorder characterized by inflammation of and occlusion of small arteries and veins in the limbs.

The group was videotaped during their analysis of the problem, a process which lasted about 20 minutes. Immediately after the session, the students were led to interview rooms, where they watched the video of the session. Trained student interviewers asked the subject to recall their thinking during the problem analysis. These sessions were audiotaped. Both the audiotapes and videotapes were transcribed and coded.

The stimulated recall procedures revealed far more information about cognitive processes during learning than analysis of verbal interactions alone. While the verbal interactions revealed causal reasoning among group participants, other cognitive processes, such as theory building and meta reasoning, were revealed far more in the stimulated recall. One reason for this is that during verbal interactions, usually only one person speaks at a time, but all learners may be thinking, questioning, reasoning, or holding ideas in abeyance as they remain silent.

From analysis of the stimulated recall tapes aligned with the videos of verbal interactions, a pattern of dealing with anomalous data emerged, leading to insights into conceptual change during discourse. One student in particular demonstrated this pattern strongly. On entering the discussion of the case, student A was committed to an initial diagnosis of sepsis. During the discussion, other students presented conflicting data from the case itself and from prior knowledge. Student A's reaction was at first to hold these data in abeyance. As the conflicting data were accepted, student A gradually accepted a new theory which was constructed in the course of the verbal interaction, leading to a change in student A's concept of the case.

The protocol led to insights into factors affecting how learners react to anomalous data during the process of problem-solving. Prior knowledge was a strong factor that emerged frequently as the students drew on their background knowledge to construct explanations. Similarities between cases they had seen previously and the case at hand, such as a red streak that might indicate sepsis, some students to an initial diagnosis that proved incorrect, but was nonetheless difficult to let go of initially. Because commitment

to initial diagnoses was not strong, students were able to give up their initial ideas fairly easily.

Characteristics of the alternate theories also influenced student response to anomalous data. Specifically, the availability of an alternate explanation, the mechanism of the explanation, and the quality, especially the scope, simplicity, and fruitfulness, of the explanation all contributed to the student response to anomalous data and a willingness to consider other explanations. The deeper the commitment to an alternate theory, and the more plausible and fruitful the theory appears to be, the more difficult it is to facilitate conceptual change.

A third factor was the characteristics of the anomalous data itself. The source of the data was particularly important in this group, and the group members were sophisticated enough in their problem-solving experience to question the credibility of the sources of information as members contributed ideas. Ambiguity of data also entered into the discussions. Problems, such as medical cases, may contain ambiguous data leading to multiple interpretations among group members, which in turn leads to increasing opportunities to confront anomalous data.

A fourth and final factor uncovered in this study is the choice of strategies employed by the learner in processing anomalous data. Deep processing tends to lead to conceptual change. The students in this study, with considerable background knowledge in the sciences and two years experience with problem-solving, were able to use deep processing skills in analyzing the problem. Younger or less experienced learners may not have these processing skills at their disposal.

This study looked only at the analysis phase of problem solving within a problem-based curricula. The cognitive processes uncovered can extend throughout the problem-solving process, and may lead to further conceptual change as the learner processes information and evaluates explanations. The study suggests that conflict created during verbal interaction was sufficient stimulus to create cognitive conflict, leading to conceptual change. One problem in interpreting the results is determining what exactly created cognitive change: the problem-solving process, or the social interaction?

Weidner (2000) examined patterns of concepts among medical students taking a neuroanatomy course, comparing students in a problem-solving context with those in an information-gathering context. One purpose of this study was to isolate the problem-solving aspect of PBL from other factors known to affect learning, such as small-group processes, discussions, and other social learning aspects. Among the multiple questions investigated in the study, the following had relevance to the current review:

- Does one context promote acquisition of domain knowledge and concepts more than the other?
- Do these instructional contexts result in different knowledge organizations as measured by Pathfinder networks?
- How stable are the Pathfinder networks that are generated under each of the contexts?
- How do novice knowledge organizations emerging from each context compare to those of experts?

- Are there differences in the retention of concepts based on the context in which they are learned?

Weidner's subjects for the study consisted of 22 out of 24 medical students enrolled in a Human Functional Neuroanatomy course that met eight hours per week. Of the 22 students who agreed to take part in the study, 21 completed the delayed-phase (delayed post-test) portion of the study. After developing two PBL cases based on cranial nerve anatomy, the author divided the class into pairs. Six pairs received a Problem-solving (PS) version of the first case, while the remaining pairs received an information-gathering (IG) version of the same case. For the second case, the contexts (PS vs. IG) were switched for each pair. In the PS context, students were given a case involving an imaginary patient who displayed several symptoms. Students used a commercial multimedia computer neuroanatomy atlas to investigate the symptoms, form an understanding about the underlying neuroanatomical structures, and develop a diagnosis. In the IG context, students were given a list of questions to answer using the same multimedia program. The questions related to the same anatomical structures that the PS students would be led to. Student pairs worked independently with the software to complete the units.

Prior to each instructional unit, students were given an instructor-designed matching and multiple-choice test on the relevant cranial nerves and their functions. The author also had students evaluate relationships between 15 terms relevant to each topic. The student-perceived relationships were analyzed for Pathfinder Associative Networks using the Knowledge Network Analysis Tool (KNOT), a multivariate analysis program

designed to analyze and create graphical representations of associative networks. The same instruments were used in a post-test following the two units. A delayed post-test was administered six months after the learning phase. In the delayed phase, seventeen of the students completed the assessments in the researcher's presence. The remaining four were mailed packets which they returned by mail or fax.

In addition to assessing the students, the researcher also had the instructor complete the word relationship assessment. This was used as a comparison between an "expert" and "novices" in assessing cognitive changes during instruction.

There was no significant difference between students in PS and IG groups on the pre-test scores. As might be hoped, all students showed significant learning gains on the post-test. Students who learned in the IG context, however, showed slightly higher gains than the PS students, and had higher correlation scores on their PFNET, indicating a higher initial agreement with the "expert" model than the PS context students achieved.

Over time, however, the PS students appeared to have the advantage. While there was little significant difference between PS and IG learning contexts on the delayed post-test, students who learned the material in the IG context showed more knowledge decay than those who learned in the PS context. PFNET correlations remained more stable for knowledge learned in a PS context than knowledge learned in an IG context.

Besides learning context, prior knowledge appeared to be a factor in knowledge retention. Differences on the pretest scores were not statistically significant across the class; nevertheless, students who scored at the higher end of the range on the pretest

showed more knowledge retention on the delayed post-test than those who scored initially at the low end of the range.

The subjects in the Weidner study were neuroanatomy students who can be expected to have a high degree of relevant prior knowledge, though the amount of knowledge varied somewhat across the group. A second study involving learners with high prior knowledge involved college-level instructors in a workshop where they were learning to use EVOLVE, a computer simulation of microevolution that employs Hardy-Weinberg principles. Soderberg and Price (2003) observed two sessions of 3-hour problem-based lessons taught by a professor who had used the program frequently in class. The EVOLVE program allows students to manipulate selection, genetic drift, and migration (gene flow) to observe effects on a population over time.

The professor selected for the study was asked to pose a question he would use in the class, then solve it himself in a think-aloud session. The researchers also conducted interviews with five undergraduate students to uncover typical misconceptions that students may hold about selection, microevolution, and genetic drift as the students used the computer software.

During the observed workshops, the professor posed the following problem to the participants: Does evolution of a dominant allele proceed faster than that of a recessive allele with a comparable phenotype? As students struggled with the concept of evolution of an allele, the professor clarified the question to, “What is the effect of increasing the selection pressure? What is the effect when you have selection operating more strongly on a population?” Through back and forth discussion with the professor, the question was

further simplified to, “Does selection against a dominant allele eliminate it faster than selection against a recessive allele?”

The students were then presented with a scenario involving a population of birds with long wings (dominant trait) or short wings (recessive trait). Some of the birds are blown off course and are stranded on an island far from the mainland. The professor guided the students through the initial manipulation of the program as they explored the effects of population size and selection factors on the change in gene ratios over time. Each time the students entered new data, the professor asked them to hypothesize the outcomes, forcing students to recognize and confront their own preconceptions.

The workshop instructors demonstrated some of the same misconceptions that the interviewed undergraduate students had shown. The belief that selection is always a negative pressure, that allele frequencies at equilibrium are always 50:50, and that runs of a given model will be identical if no changes are made to the parameters (which ignores genetic drift and views selection as deterministic) were the most widely-held misconceptions that emerged as instructors manipulated variables in the program. As lesson proceeded, students shifted from thinking about genetics from individual or familial level to populational level, a framework necessary to problem-solving in population genetics and microevolution.

In this study, the experienced professor’s protocols in using the EVOLVE program to solve a problem and to develop an understanding of population genetics enabled the professor to bring out and confront assumptions and misconceptions about population genetics. The professor’s goal in this lesson was to get students to understand that the

term “dominant” describes the relationship between two alleles, and can’t be determined by the frequency of the phenotype or the allele, nor by the fitness of the allele. The professor’s explicit and unambiguous use of genetics terms contributed to his goal. While the effects of the program and the professor’s pedagogy were not measured quantitatively, the researchers indicated that both had contributed to the learners’ conceptual change over the course of the lesson.

Unlike the independent teams in the Weidner study, the workshop students received considerable scaffolding from the instructor, and engaged in a great deal of discourse with the larger class. Scaffolding provided by the instructor was a critical factor in the lesson. The professor asked students, after entering parameters, to make predictions about what would happen. Students were to visualize what the graph would look like. This forced the students to confront their assumptions instead of just “finding out what happens.” While students did experience conceptual change in this study, as the medical students in Weidner’s study did, the design of the Soderberg and Price study demonstrates the importance of parsing out multiple variables in the learning context before drawing conclusions about any one factor. In this instance, while conceptual change took place, it is difficult to know which factors had the greatest influence: the problem-solving context, the professor’s scaffolding, use of the technology, or the class discourse. Most problem-based learning, however, is more student-centered, as was seen in the Weidner and the de Grave, et al. study.

The learners in the Soderberg and Price study were adults with experience in teaching population genetics; hence the learners began the exercise with prior knowledge of the

subject and the ability to engage in metalearning around the topic. What happens with students who are much younger, for whom metacognition and abstract thinking are difficult?

Westbrook and Rogers (1996) examined changes in conceptual understanding and reasoning processes in ninth grade high school students enrolled in a physical science course. The students were studying properties of matter, and were engaged in a unit on flotation. The purpose of the study was to examine whether the concepts that students hold are affected by generating and testing hypotheses. Of the 63 students who were enrolled in the classes, 21 completed all of the assessments and were absent no more than two days during the unit.

The authors proceeded from a Piagetian viewpoint, stating that concrete thinkers more likely to maintain alternate conceptions after instruction than abstract thinkers, possibly because concrete thinkers lack the logical reasoning abilities needed for the process of considering the deficiencies of their own hypotheses and the merits of competing scientific hypotheses. Without these abilities, students can't evaluate the merits of scientific explanations and find them plausible and fruitful. The authors hypothesized that students who are concrete thinkers and cannot think reflectively, and who require the manipulation of concrete materials for conceptual development, are unlikely to change their thinking as a result of being told about common misconceptions. It is more reasonable to believe that students will need laboratory opportunities to test their own hypotheses.

The students learned about flotation in problem-based laboratories. Though the exercises bore more resemblance to inquiry than to problem-based learning, the task-based nature of the lessons provided some useful insights into conceptual change problem-solving.

Prior to the unit, the researchers administered Lawson's Classroom Test of Scientific Reasoning (CTSR) to measure "development" in Piagetian terms, and the 36 item Test of Integrated Process Skills (TIPS) to examine students' abilities to identify variables, identify and state hypotheses, assess operational definitions, design investigations, and graph and interpret data. Changes in student understanding of flotation monitored using concept maps and word sorting activities. Word lists were generated from students' own hypotheses about flotation. Students completed these three times: prior to the study, after a class discussion on data related to density and activities about volume and displacement, and after the discussion over students' experiments with floating. Of the 21 students who complete all assessments, five were concrete thinkers, thirteen were "transitional", and three were formal thinkers. Thirteen were able to use the concept of the conservation of volume in answering questions on the instrument related to flotation, while eight could not.

The students were then presented with a problem: why do some things float while others do not? The open-ended nature of the problem question allowed students to formulate and test hypotheses regarding factors affecting flotation. As students generated hypotheses, their alternative conceptions around the concept of flotation emerged. Student-generated hypotheses that came out in a class discussion included weight, the

amount of air in the object (“hollowness”), mass, density, properties of the water itself, shape, ability to hold water, temperature, and volume.

During an instructional period that followed, students were asked to examine the word list generated earlier and categorize the words into two groups: things explaining floating and things that do not explain floating. Students also drew concept maps using words from the word list.

Students then entered the exploratory phase of the unit. In this phase, students designed simple experiments to test their hypotheses. The majority of students chose to test either weight or shape as a factor affecting flotation. Students manipulated pieces of modeling clay and dropped the clay into water to see whether it floated or not.

Following the exploratory phase, students were given the word sort and concept map tasks again, and the results of these tasks were analyzed for evidence of conceptual change.

Eleven of the students tested the weight hypothesis, beginning with the assumption that the weight of the object affected its ability to float. The students tested pieces of clay of different weights to see if they would float or not. Of those eleven, only one identified weight as a factor on the final word sort, whereas of the nine students who did not test weight identified weight as a factor. A Chi-square test of the results showed that the difference was significant ($p=.05$). Hypothesizing and direct testing appeared to have helped these students change their thinking about weight as a factor affecting flotation, as indicated by comparisons of the first and final word sorts.

The results were different, however, for students investigating shape as a factor. There were no significant differences on the final word sort between students who tested shape and those who did not; rather, selection of shape as a factor in flotation correlated closely with the students' ability to use the conservation of volume in their answers. While the conservation of mass is classified as concrete thinking on the CTRS, conservation of volume requires formal thinking. The role of shape also involves volume, mass-volume ratio, and mass-volume ratio of air contained inside the object, all of which are difficult concepts for students to understand and to hold in their memories simultaneously while developing hypotheses and explanations.

While developmental factors may have affected understanding, the ability to formulate and test hypotheses also appeared to be a factor. In one investigation, for example, students shaped clay into a pancake shape, a ball-shape, and a cube. In all three cases, the clay always sank. The students did not think to shape the clay into a hollow or boat-shaped object. The investigative experience led to a conceptual understanding that persisted after class discussions. Whether this is due to developmental factors, faulty hypothesis testing, or both is difficult to discern.

One factor that could influence the learned outcomes of a PBL course is the bootstrapping problem, described in a paper by Sherin, Edelson, and Brown (2004). The bootstrapping problem is a problem of prior assumption on the part of the curriculum writers or the instructor. In designing task-structured curricula, the designers must make critical decisions about where to include explicit instruction regarding a concept and where to assume the students understand a particular concept and are ready to build upon

it. These assumptions are necessary; otherwise curricula would grow unwieldy with repeated instructions of basic concepts. Further, the learning goals of a unit dictate the depth of knowledge required for any particular concept. As instructors teach a PBL unit, they must make decisions regarding their own students: How deeply do they need to understand a concept in order to understand the problem and its solution? What parts don't they need to understand? Instructors must make assumptions regarding both the depth and the diversity of their students' prior knowledge.

Sherin and colleagues examined the effects of the bootstrapping problem, asking: When instructors make critical decisions about where they need to explicitly teach concepts and where they can make do with students' existing understanding, are those assumptions about existing understanding valid? What happens in individual cases where student understanding does not fit what was assumed?

To examine these questions, Sherin and colleagues studied a classroom of middle school students who were engaged in a PBL unit on global warming. The students needed to explore the phenomenon of global warming to be able to answer the following questions:

1. How could we tell if the Earth were getting warmer?
2. What might be causing global warming?
3. What are the predicted implications of global warming for individual countries and what responses should they pursue?

To gather information necessary to answer these cross-discipline questions, students carried out a number of exploratory activities, including measuring temperature variation

within the school over time, examining historical temperature data, studying temperature maps of the earth, using computer software to learn about the effect of solar light on the earth, studying databases of human impact on the earth, and examining several prediction models about the effects of global temperature change and carbon dioxide levels.

Lessons regarding the effect of solar radiation on the earth and lessons on the greenhouse effect relied on intuitive understandings of the nature of light and of energy. The curriculum assumed that students would know that light radiates from a central source, and that it covers a large area with less intensity the greater the distance from the light source. The project also assumed that the students would have mastered some basic concepts about the Earth and the solar system, including the concepts that the Earth and the sun are both essentially spherical and are separated in space by a large distance.

The researchers carried out clinical interviews with selected students before and after they participated in the Global Warming Project curriculum. Students were asked a series of questions about light and about the earth and the sun. To examine their understanding of the relationship between solar radiation and earth temperatures, students were asked to explain why Florida tends to be warmer than Alaska, and why summers are warmer than winters.

Most students, when asked what would happen if a lamp held near a wall were moved away from the wall, thought that the light would spread out, which is reasonably consistent with the scientific model. Some believed that the rays would become dimmer. The idea of light “spreading out” affected their concepts of how the earth is warmed.

Some students believed that the sun's rays struck the earth only at the equator, then "spread out" from there, becoming dimmer and cooler.

Students who were the exceptions, whose understanding was not consistent with a scientific model, provided useful insights into the bootstrapping problem. One student, Dedra, used a sphere of illumination model to explain what would happen if a lamp were moved away from a wall. Dedra believed that the illuminated area would become smaller rather than larger. Her concept of light as a sphere, whose contact with the wall grows smaller as the lamp moves back, is inconsistent with a radiating model. Dedra also believed that when a light switch is turned on, the light bulb illuminates instantly, with no delay. While this may be consistent with children's observations, which are not always discerning, it is inconsistent with a scientific model. In both cases, Dedra had prior understandings that affected her ability to understand light as something that travels. In the course of her participation in the PBL unit, her understanding about "instantaneous" illumination changed slightly, but her sphere of illumination model did not.

Another student, Mitchell, believed that the equators are warmer than the poles because they are closer to the sun. His mental model included a concept of scale distances that was inconsistent with the scientific model. This concept did not change significantly during the unit, which could have interfered with Mitchell's understanding of the global warming.

These students whose alternative conceptions were little altered by their participation in a PBL curriculum point out the need for more work to understand the extent to which the bootstrapping problem undermines the success of PBL curricula. While it is

reasonable to expect teachers to make some assumptions about some conceptual knowledge — for example, a teacher should not have to go to the extreme of having to teach concepts of object permanence which we can assume were learned in infancy — individual curricula need to be examined for underlying assumptions regarding student conceptual understanding to determine whether the assumptions are borne out. Further, a more work is needed to look across task-structured curricula in order to develop a broader account of the learning process, including concept formation and problem-solving skills, that occur within these curricula.

Transfer of concepts

Because learning in PBL takes place in the context of a problem, concern arises over whether the concepts learned can be generalized to other settings. Indeed, implicit in most teaching practices is the assumption that a concept, once learned, can be abstracted from the context in which it was learned and applied within other contexts (Brown, Collins, & Duguid, 1989). However, knowledge application is a complex process. Situated cognition suggests that context is intertwined with knowledge, in that features of a context radically alter the way in which knowledge is represented, which hampers the process of transfer.

Levinson and Murphy (1997) examined the issue of conceptual transfer from a different angle. Rather than looking at whether concepts learned in a PBL setting transfer to other settings, they looked at whether students who learned scientific concepts in a traditional classroom transferred their knowledge to a task-based classroom. Results of

this study are germane to the discussion of the effects of knowledge that follows this section.

The study took place in England, where the curriculum includes a program of Design and Technology (D&T). The program specifically states that students should be able to apply skills, knowledge, and understanding from other subjects to D&T. This implies that knowledge should transfer from one domain to another, and assumes that concepts taught in science are generalized enough to be applied spontaneously elsewhere.

However, the D&T curriculum is not coordinated with other curricula, including science. For example, students learn about voltage in science class at age 15-16, but use voltage in D&T lessons much earlier, ages 11-14. Furthermore, despite expectations of curriculum designers that knowledge will transfer, D&T teachers assume that students will not arrive in their classes with the concepts, and that scientific knowledge will have to be taught on an as-needed basis.

The authors studied twelve Year 8 (12 - 13 year old) students enrolled in a D&T class. In the unit under study, students were given the task of designing a moisture sensor. The sensor could be designed to light up in response to dryness, as in a sensor for a potted plant, which involved the use of a resistor that would break the circuit between two wire probes when the voltage reached a particular level, as when the probes were inserted into moist soil. Alternately, the sensor could be designed to detect wetness. An example of such a sensor might be a device that would buzz when a bathtub was full. Students had to design and solder a circuit board for their selected sensor. The circuit board provided a

different model of a circuit than they had encountered in their science classes, a difference that the technology teacher did not make explicit.

During the first three weeks of the 7-week unit, students were taught about circuits, but in a way disconnected from the project. The emphasis of the lessons was on names of components, with a discussion of what components do, but not in relation to the moisture sensor.

As students began the design phase of the unit, the selected students were interviewed to determine their level of knowledge about electrical circuits. Knowledge of circuits was not a stated outcome of the project, but students did need to understand an electric circuit to understand how their moisture probes worked. During interviews, students were asked to make a small light bulb light up using equipment they would have seen in a science class: light bulbs, wires, and batteries. Students were asked how the circuit worked, and asked how they would make the bulb shine more brightly. They were shown items and asked if the items would conduct electricity or not. Students were asked to explain the purpose of soldering the joints in their circuit boards, to determine whether they related the boards to prior lessons about circuitry. Given an LED bulb, they were asked to explain its function, the difference between an LED and a light bulb, and explain how they would connect the LED in their circuit. Finally, students were asked to discuss a sensor in terms of input, process, and output to examine how well students tied their knowledge to the task they had been given. The coded responses fell into four categories:

Weak: Unable to make test circuit even with prompting, did not draw on prior knowledge when explaining task.

Unlinked: Constructed text circuit and had prior knowledge of circuits but did not relate it to the task when questioned.

Linked: Able to make the test circuit, had considerable prior knowledge, and used the knowledge for some explanations about their tasks.

Sophisticated: Able to make the test circuit, had considerable scientific knowledge, used the knowledge as explanations about aspects of the task, could identify and explain a range of problems.

The authors also conducted multiple classroom observations during the unit, videotaping the classes for later transcription and analysis. Four target students were selected for further interviews throughout the unit. Student-teacher and student-student dialogues were transcribed and analyzed for concept development, and student behaviors were analyzed as a means of detecting application of their knowledge to the design task.

During the interviews, all students showed some crucial misunderstandings of how circuits worked. Explanations of circuits tended to be decontextualized from their moisture probe projects. When asked about electricity in circuits, students talked about “it” going around and around without a clear idea of what “it” was. Some said “it” was electrons, but their model was a water flow model, which was not surprising since the teacher used a similar model when teaching about circuits. Some who did relate their knowledge to the moisture probe thought that moisture would go through the meter, perhaps influenced by the water-flow model of electricity presented in class. Students used terms such as “message,” “moisture,” and “voltage,” almost interchangeably, and spoke of electricity “pouring” through their circuitry. Student explanations were mostly at

a superficial systems level; that is, students could explain what happened in their circuits, but they could explain neither why nor how. One student with sophisticated knowledge gave good explanations of electrical circuits, but did not understand the role of resistors and other components in designing the probe. This student's knowledge was sophisticated enough, however, that he was able to recognize his own lack of understanding.

Through classroom observations and informal interviews as students worked on their designs, the authors uncovered a general trend of disconnect between the scientific knowledge, taught at the start of the unit and in earlier science classes, and the students' technological design decisions during the design phase of the unit. The disconnect was exacerbated by students' level of knowledge of circuits. Students with a sophisticated knowledge of circuits were generally successful at designing appropriate probes and could give reasonable explanations for their design choices. For example, two boys who showed the strongest understanding of circuitry were able to explain that for a probe to detect moisture in a potted plant, the soil needed to provide a continuous medium between the paired probes. Dry soil did not provide the continuous medium required, so the probe would not light when the soil was dry. A female student who did not have good understanding, however, had difficulty designing a probe to measure condensation on a window. The probe required a pad, not two rigid probes, to be successful, but though this student knew that a continuous medium of impure water was needed to create a circuit, the knowledge did not influence her design. She chose rigid rods as probes, as did a male student who was trying to design a probe that would hang on a washing line and sound a

buzzer if there were rain. In both cases, the rigid probes extending from the sensor were inappropriate for probes designed to detect rain or condensation, and both designs failed. The two boys with sophisticated knowledge, by contrast, had recognized the problems inherent in designing probes to detect rain, and for this reason had decided to design a plant moisture probe that used rigid probes inserted into the medium. One student with poor knowledge, who also designed a plant moisture probe, argued that her probe was designed to measure dryness, not moisture, and was unable to apply her limited knowledge of circuits to explain how moisture affected the probe's function.

In testing their probes, students also demonstrated disconnect between knowledge and its application. In the first design lesson, the teacher demonstrated that touching the two rigid probes together completed the circuit, as did touching both probes to a moistened finger. He then showed that the circuit could be made to work in reverse, so that the bulb would not light when his finger was moist, but would light when his finger was dry, which would be the desired case in probe for measuring moisture in a potted plant. The demonstration was short, taking only a few minutes, and did not include an explanation of the role of a transistor switch in the second part of the demonstration.

When students tested their probes, they followed the same set of testing procedures as the teacher had demonstrated, whether the test was appropriate or not. For example, if touching the probes together did not make the bulb light, then there was a fault in the circuit. On seeing this, however, students would still continue to the second test using moistened fingers, and were unable to explain why. Their testing procedures were ritualized, copying the teacher's demonstration without applying the procedures to their

knowledge. Even the students with sophisticated knowledge carried out the procedures exactly as demonstrated. In fact, one of the students with sophisticated knowledge attempted to test his plant moisture probe by holding on to one probe rod while his friend held the other. When questioned, he admitted to the researcher that he really didn't understand what was going on. Students who were questioned were able to describe the two parts of the procedure that had been demonstrated, but only said that the tests showed them that the circuit was working. They were unable to grasp that the two parts were two different tests.

Situated cognition effects may have a strong effect on the ability of students to apply knowledge learned in one context to a problem in another. However, the Levinson and Murphy study was performed on students whose knowledge of electricity was at the novice level compared with, for example, college-level electrical engineering majors. More study would be needed to determine how much of the problem of transfer was due to the students' level of conceptual knowledge, and if a deeper conceptual understanding learned across multiple contexts can help students abstract the knowledge and better transfer it to other contexts.

Emergent factors

Two factors strongly affecting conceptual change emerge from the papers in this section. Prior knowledge is a powerful factor. Students draw on their background when analyzing problems, and students who have seen similar problems before or who have related knowledge have a cognitive advantage. Those with high knowledge levels tend to

remain at high levels compared with their classmates. Chan and Bereiter (1992) found similar effects in high school students outside of a PBL setting when confronted with anomalous data, in this case a statement about natural selection that conflicts with common misconceptions about selection. Students with low knowledge tended to assimilate parts of the statement into existing knowledge, ignoring parts and distorting others to make the statement fit their own ideas. Students with high knowledge tended to recognize the conflict with their pre-existing ideas and attempted to fit their ideas to the new knowledge.

Related to prior knowledge is development. Students with deeper processing skills are better able to reason within a problem-based setting and better able to develop new concepts than their peers. Students who are less able to formulate hypotheses and less able to reason are more likely to be satisfied with their prior conceptions. Similar conclusions are found in studies on student reasoning outside of PBL. For example, Lawson, et al. (1993) found in a study on college biology students that hypothetical-deductive reasoning ability, a construct that Lawson aligns with Piagetian developmental stages, was a critical factor in conceptual change.

The factors of development and prior knowledge, then, are not unique to problem-based situations; however, studies in other settings support the idea that these factors, important in other contexts, are likely to be important within a PBL context as well. The question arises, then: does PBL offer any unique advantage to assist students in raising their knowledge and developmental or reasoning levels? The deGrave, Weidner, and Soderberg and Price studies all suggest that social interactions, a common factor in PBL

curricula, may assist students by increasing opportunities for cognitive conflict and through scaffolding offered by peer example and more formally by instructors. Chan and Bereiter (1992), however, arranged their study to compare conceptual change in students who worked alone and students who worked in pairs or groups, and found no significant conceptual change in students who interacted with their peers, but slightly significant change in older students who worked in a peer conflict condition, a condition in which students were presented with statements conflicting with their prior conceptions and worked together in processing the statements. High conflict combined with social interaction may be a factor that fosters conceptual change.

Student reasoning within task-based learning

Development of hypothetico-deductive reasoning

An early study to examine and describe reasoning skills in PBL contexts was a comparative study conducted by Patel, Groen, and Norman (1991) at two Canadian medical schools. One school was using a conventional curriculum (CC) in which students studied the basic science in lecture classes for the first year and a half, then were given clinical exposure. The second school had adopted a PBL curriculum format (PBLC) in which students were introduced to clinical problems from the beginning of their training, and basic science teaching was integrated within the context of the problems. The authors sought to describe the reasoning processes used by students at various stages in their

medical school career, and how manipulating the order in which problems and background information are presented might alter their reasoning.

Prior to this study, two of the researchers published a study examining the relationship between reasoning strategies and medical expertise (Patel, Groen, & Arocha, 1990). Using a rule-based model drawn from artificial intelligence research, the authors proposed that forward reasoning, proceeding from background data to hypothesis generation, is characteristic of expert clinical reasoners, and is most effective when the problem is well-structured. Backward reasoning, in which an hypothesis is employed to generate data or to guide the search for data, is characteristic of novice reasoners, and is most effective in situations where the problem is ill-structured. Among medical practitioners examined in the study, forward reasoning tended to lead to more accurate diagnoses than backward reasoning.

Patel, Groen, and Norman applied this model to medical students engaged in PBL and non-PBL curricula. Groups of students at three levels of training were selected at each school (CC and PBLC). Beginners were those within their first six months of study. Intermediate students were in the middle of their medical training. For CC students, this corresponded to their early exposure to clinical settings. Senior students were those in their final year.

The researchers prepared four texts for use with the study. The first text was a clinical case involving a young man suffering from acute bacterial endocarditis with aortic insufficiency. The case described symptoms of the disorder and possible causes, including puncture wounds on the arms (signifying drug use), abnormal heart sounds,

hemorrhage in one eye. The other three texts were basic science texts described physiology of fever, circulatory dynamics, and microcirculation, all of which relate to stages of development of the disorder and could explain underlying causes.

Two basic quasi-experimental designs were used. In the first, students from both schools were presented with the basic science information first, then given the clinical problem. In the second, students from both schools were presented with the problem first, then given the underlying scientific information.

In the first phase of the study, six students from each of the three levels at both schools were selected, a total of 36 students. The students first read the science texts, then were given the clinical case text. Students were asked to give a diagnosis and to explain the underlying physiology of the case with respect to the science texts.

In the second phase of the study, twelve students in each of the three levels at both schools were selected, a total of 72 students. The students were given the clinical case to read first and asked to explain the underlying pathology (spontaneous explanations). The students were then given the three scientific texts to read and asked again for an explanation of the problem in relation to the new information (biomedically primed explanation).

Student responses were recorded and transcribed, and the transcriptions were coded with reference to three types of propositions: those present in any of the three basic science texts, those present in the clinical text, and those not present in any text, classified as inferences. These could include personal knowledge or experiences, or clinical knowledge.

The responses were used to generate a semantic network for each student. Each network was compared to a reference network that contained the causal mechanisms of acute bacterial endocarditis using the information in all texts. The “nodes” in the networks consisted of propositional statements made by the students, while “links” were the relationships between the propositions. Links were classified as causal (backward directed) or conditional (forward directed if-then statements). The directionality was important in determining the reasoning used by each student. Causal links, constituting backward reasoning, generally describe how the pathology causes the symptoms, leading away from a diagnosis; that is, from the diagnosis to the facts. Conditional links, typifying forward reasoning, move from observable facts through explanations to a final diagnosis. Backward reasoning is a characteristic of hypothetico-deductive reasoning, which begins with stating an hypothesis and leads to a search for facts supporting or refuting the hypothesis. Though backward reasoning is taught explicitly as scientific reasoning and is essential for hypothesis testing, forward reasoning is frequently associated with “expert” reasoning in problem-solving studies, while backward reasoning is more often associated with “novice” problem-solvers.

When given the scientific data before the problem, PBLC students tended to use more causal (backward) links in their explanations than did the CC students. They also gave more elaborations as part of their answers. Beginning PBLC students stated more science propositions and clinical propositions than did senior PBLC students. Beginning CC students on the other hand used more science propositions and *fewer* clinical propositions

than did senior CC students. This may correspond to the CC curriculum structure, since beginning students would not have had any exposure to the clinical setting.

When given the problem only, PBLC seniors used more forward reasoning initially as they gave their spontaneous explanation of the clinical problem, then used both forward and backward reasoning as they provided further explanations. Beginners and intermediate students gave more coherent answers than the senior students, in part because the senior students saw more possibilities and made more conjectures. All PBLC students made more inferences than the CC students. Beginners and intermediates made mostly basic science inferences, whereas the seniors made more clinical inferences. Beginning CC students demonstrated very naive understandings of the disease process compared with senior students, which was expected given the structure of the CC curriculum. Though CC students used more scientific information than PBLC students in their spontaneous explanations, they did not necessarily use it more accurately. CC seniors showed more global coherency in their answers than PBLC seniors, and this was at least partly due to the greater willingness on the part of PBLC seniors to draw more inferences and speculations. PBLC seniors used local coherency in the subcomponents of their answers, but did not tend to tie the subcomponents together for global coherency. Overall, CC students used more forward reasoning in their explanations than PBLC students.

When presented with the scientific texts following the spontaneous explanations, all students used both texts in formulating their primed responses. PBLC students showed decreased global coherency in their responses as they tried to incorporate the scientific

information, with more local coherency. This was partly explained by the use of unresolved alternatives in their answers, which CC students did not use at all. PBLC students continued to use more backward reasoning than CC students. While CC beginners used inferences in their explanations, CC seniors used very few. PBLC students at all levels used inferences. CC students tended to use more forward reasoning in their explanations than PBLC students, even after reading the science texts, and showed fewer attempts to explain details of their problem solutions using the data from the science texts. The CC students tended to compartmentalize the information, using only clinical text data to explain the clinical problem and leaving out the science data. The authors speculated that this might relate to the structure of the CC curriculum, in which clinical experiences are separated from the basic science courses.

In general, both PBLC and CC students were able to spontaneously use forward reasoning, which is associated with “expert” problem-solving. PBLC students, however, tended to engage in more backward reasoning than forward reasoning. This seems a reasonable outcome, however, since these students were employing the hypothetico-deductive model that they were explicitly taught in their curriculum. More experienced PBLC students used more forward reasoning than the beginning students, but the appearance of forward reasoning in PBLC students appears to be delayed compared with CC students, perhaps because of the explicit use of backward reasoning during problem-solving in their coursework.

PBLC students appeared to be more willing to form inferences, alternative explanations, and unresolved alternatives than CC students. They were also more able to

integrate science information with clinical information to solve problems, which resulted in use of both forward and backward reasoning as the students looked to the scientific data to explain what was seen in the clinical case. PBLC students at all levels used about the same amount of clinical data in their explanations, suggesting that they learned and applied a methodical approach to clinical problem solving starting very early in their training.

The authors imply that use of backward reasoning, associated with naive problem solving, is a handicap to PBLC students, citing a work by Sweller and others (1983), in which students learning mathematics switched spontaneously from backward reasoning to forward reasoning after a great deal of practice working with physics problems. As students switched the direction of their thinking, they omitted steps in the reasoning chain, a characteristic of expert reasoning. In the same study it was also found that prior training in backward, hypothetico-deductive reasoning interfered with the development cognitive changes on which forward-directed thinking depends. Patel, et al. (1990) also analyzed factors that interfered with the use of forward reasoning, including task structure and prior knowledge. The authors found that backward reasoning replaces forward reasoning when facts are tested for their consistency against the problem solution, which may be similar to what the PBLC students were doing as they incorporated facts from the science texts into their explanations. CC students, who tended to compartmentalize information, tended not to explicitly relate the science facts to the clinical problem. It could be, then, that the PBLC students' apparently greater use of backward reasoning was an artifact of their more explicit use of all facts available to a

case, as well as their greater willingness to propose multiple hypotheses. Furthermore, as was shown in the De Grave, Boshuizen, and Schmidt paper (1996), student mental processes are not always evident from their verbal responses during problem solving. Asking students to engage in elaboration after the fact, and explain what they were thinking during their reasoning process, could reveal underlying mental processes that were not considered in Patel, Groen, and Norman's study. Lemieux and Bordage (1992) suggest that something more than linear processing occurs during clinical reasoning. A structural semantic analysis of clinical reasoning by medical students and experts revealed that experts had a wider network of knowledge to draw upon when making a diagnosis, and therefore had a deeper mental representation of the problem to begin with.

Hmelo, Gotterer, and Bransford (1994) also looked at reasoning processes that PBL students engage in, in part to develop measures that can be used to assess reasoning, and in part to replicate the findings of Patel et al. using a paper-and-pencil instrument. Hmelo and colleagues predicted that PBL students would engage in more hypothesis-driven reasoning than non-PBL students, because hypothetico-deductive, or backward, reasoning is taught in PBL coursework. They also predicted that hypothesis-driven reasoning should result in more coherent explanations, where coherence is defined by the length of the reasoning chain produced. Longer reasoning chains are associated with expertise in problem-solving, implying that expert problem solvers are using more inferential reasoning and can tie more facts together as they reason about problems. Novices have shorter reasoning chains, possibly resulting from more fragmented

representations of the problem. Novices may, in fact, have trouble recognizing a problem altogether.

The study was a quasi-experimental study, involving self-selected groups. Twenty PBL students were chosen from an elective PBL class. Twenty non-PBL students were selected from a different elective class. These students has never taken the PBL class. In each condition, half of the students were in their second year of medical school, and half were three months into their first year.

The PBL elective was structured such that eight students met two hours each week with a facilitator. Students were given a case history to diagnose, with some information on which to begin diagnosis, but the information was insufficient to develop a complete explanation. The group had to evaluate and define aspects of the case to gain insight into the underlying causes of the disease process. Students collected more information from the facilitator and generated learning issues (topics about which the group decided more information was needed). The group members divided the learning issue tasks among members, who sought more information before the next class by going to the library, the internet, or consulting with experts. At the next meeting, they shared the information and further analyzed the problem. Non-PBL students did not have the equivalent experience in their coursework.

The study case regarding childhood diabetes was presented to both sets of subjects in four segments: presenting the case, history, physical examination, and laboratory data. At the end of each segment, students explained in writing the underlying causal mechanisms to account for the problem. At the end of the entire case, students explained what they

would want to learn more about to better understand the case and how they would go about meeting their learning needs. Artifacts were collected and coded for reasoning strategies, coherence, learning self-assessments (learning issues), and learning plans. Two raters, working independently of one another, reached 92% agreement when coding the artifacts.

Coding revealed that PBL students were significantly more likely than non-PBL students to use hypothesis-driven reasoning ($p < .001$). Non-PBL students were more likely to use data-driven reasoning. Second year non PBL students were more likely than second year PBL students to use other relations in their reasoning ($p < .05$). These results suggest that PBL students were able to transfer their reasoning strategies learned in class to the study problem.

While second-year non-PBL students realized that there were connections between the data and their hypotheses, they did not make clear what these connections were. PBL students were able to incorporate data into longer reasoning chains than non-PBL students, demonstrating greater coherence ($p < .01$).

Hmelo and colleagues, then, take a different view of backward, or hypothesis-driven reasoning, than do Patel and others. In the Hmelo, et al paper, hypothesis-driven reasoning was associated with more flexible knowledge and problem-solving, and a greater willingness to explore the problem. Differing definitions of “coherency” make comparisons of coherence difficult. Patel et al. looked at global and local coherence, where global coherence is the internal consistency of the overall explanation, and local coherence refers to the consistency within the portion of an explanation that explains a

specific part of a clinical problem. An explanation may have local coherence without global coherence if it explains individual components without tying them together. A globally coherent explanation ties together all subcomponents of the problem. Either global or local coherency could result in long reasoning chains, which may explain the differences between the two papers on the point of coherency of explanations.

Hmelo, et al. (1997) returned to the problem of directional thinking in PBL in another study on medical students, supporting the 1994 findings. In this study, 20 medical students who had participated in an elective PBL class and 20 who had taken a different elective were compared. The students were then given a text-based assessment, consisting of a story of a diabetic child. The case was presented sequentially within the text, presenting the initial complaints, the child's history, results of a physical exam, and the laboratory data. After reading each segment, the students explained in writing the underlying causal mechanisms that would account for the data presented. At the end of the assessment, students wrote about what they would need to know in order to better understand the problem, and how they would go about finding this information. The students were tested in small groups, but each student completed the assessment individually. Following data collection, the data were coded for coherence of explanation, reasoning strategies, integration of science concepts into their explanations, and the learning strategies they suggested. Coherence was assessed by the number of relational operators chained within a written explanation. Sections were scored individually for coherence, then averaged. Reasoning strategies were assessed as hypothesis-driven (backward-chain), data-driven (forward-chain), other relations, or unjustified assertions.

Use of science concepts was coded from each subjects' individual explanations, including any statements referring to anatomy, physiology, biochemistry, microbiology, or pathology. Student learning plans were assessed according to the types of learning resources students mentioned, such as textbooks, other science books, experts, or journals.

Results revealed that PBL students were more likely to use hypothesis-driven reasoning, a result consistent with the earlier Hmelo, et al. study (1994) and Patel et al., (1991). Furthermore, PBL students were able to transfer the hypothesis-driven reasoning that they had learned within the PBL class to solving the case. PBL students were able to generate explanations that were significantly more coherent than non-PBL students, incorporating more scientific knowledge in support of their hypotheses.

PBL students were also shown to be more self-directed in their learning strategies, and were more likely to use a combination of resources, whereas non-PBL students were more likely to rely almost exclusively upon diagnostic handbooks as resources.

Hmelo explored reasoning in PBL again in a 1998 paper, again working with early-career medical students. In this study, 76 students were selected from two different schools: one offering a PBL elective course (School A), the other offering an entire PBL track (School B). At both schools, volunteer students were chosen from PBL and non-PBL classes. Despite the self-selective nature of the samples, baseline equivalence scores, including MCAT scores, GPA, prior health care experience, age, and initial performance on the first problem-solving task in the sequence of tasks given in the study showed no significant difference between the PBL and non-PBL groups at the start of the study,

though there were some differences between schools. Context, however, rather than schools, was the basis of comparison in the study.

The problem Hmelo addressed in this study was that medical expertise is often studied in expert-novice studies. However, little is known about the changes in clinical reasoning that students undergo during their medical training. To address this problem, Hmelo examined changes in reasoning strategies during the first year of medical school, and compared the effects of PBL and traditional curricula on the development of reasoning skills. The hypotheses driving the research were:

- All students should develop more accurate diagnostic hypotheses as their scientific knowledge increases.
- All students should develop more coherent explanations. PBL students should have an advantage because PBL may accelerate the development of elaborate causal networks.
- PBL students should be more likely to use hypothesis-driven reasoning than non-PBL students, since this is the kind of reasoning that is taught in PBL classes. All students should use fewer unjustified assertions over time.
- All students should be able to use more science knowledge in their explanations over time. PBL students should be more able to access basic science information in the context of a problem since they are learning science in problem-solving contexts and have learned that science is a problem-solving tool.

To test these hypotheses, Hmelo created a problem set, selecting from problems that School A used in evaluation, and problems that School B had used in the PBL track but had retired. A hypertext computer program was developed to administer the problems in segments: presenting complaint, past medical history, physical exam, lab tests, additional information. After participants completed each segment, they were to type in possible mechanisms for the patient's complaint and how they would go about evaluating hypotheses about the complaint. The program recorded responses and response time. Students were given a short warm-up problem during time 1, then given the problems. Subjects participated at three times through the school year: Time 1 (August-September), Time 2 (November-December), Time 3 (March-April). Each participant was given two problems per session, with school A or school B problems distributed equally.

The results were saved in an electronic file and quantitatively coded, according to the following scheme:

- Accuracy: inclusion of one accurate diagnostic hypothesis among the set of hypotheses generated. Scored as 0 (completely incorrect), 1 (neither fully correct nor fully incorrect, often due to incorrect subordinate answers), or 2 (fully correct).
- Coherence: assessed as the number of relational operators chained in an explanation, and a measure of clinical findings accounted for in that chain.
- Reasoning strategies: data-driven, hypothesis-driven, unjustified assertions.

Data were analyzed with a 2 x 2 (condition x school) ANOVA for baseline equivalence, and a mixed ANOVA to analyze remaining data. Initial scores on the first problem set were essentially equal between contexts.

Analysis revealed that PBL students demonstrated greater improvement in accuracy than non-PBL students. This was partially attributed to problem-specific experience, based on agreement or disagreement with the statement, “I have worked with at least one case that is very similar to this case.” It was probable that PBL students had more opportunity to learn problem-solving than did the non-PBL students, and their learning was demonstrated in the assessments.

PBL students improved more than non-PBL students over time on the maximum reasoning chain and on the number of clinical findings accounted for in their explanation, showing that PBL students increased their coherence more than non-PBL students. Since Hmelo’s definition of coherence differs from that of Patel, Norman, and Groen, comparisons between these studies are difficult. However, the PBL students in Hmelo’s study were able to incorporate more scientific data into their answers than were non-PBL students, showing more integration and less compartmentalization of their knowledge. This may have been due to the way science was used in PBL courses: as a tool for problem-solving and for constructing explanations.

PBL students used more hypothesis-driven reasoning over time than did non-PBL students, which is an expected finding considering that PBL students are taught hypothetico-deductive reasoning. Their use of unjustified assertions decreased over time

more than did the non-PBL students. For both groups, data-driven (forward) reasoning was used as a supplement to other reasoning strategies.

Based on the reasoning used by PBL students and the content of their responses, Hmelo concluded that the students were not simply reasoning by analogy from specific similar cases; their reasoning seemed to be based on their mental models of science concepts. Though PBL students had more experience with solving problems around clinical cases, both PBL and non-PBL students had little actual clinical experience. Because scientific knowledge was presented in the context of problem-solving for PBL students, these students were more able to integrate their conceptual knowledge into their solutions. They relied more on hypothesis-driven reasoning, but this did not put them at a disadvantage. This kind of reasoning can have advantages when the knowledge structure of the problem-solver consist mostly of scientific mechanisms, such as when the problem-solver has limited clinical experience and limited exposure to actual or prototype cases.

For hypothesis-driven reasoning to be effective, students need their attention directed to the aspects of the problem relevant to the goal. PBL students received such scaffolding within the context of their classes, either from the facilitator or from group members. As they proceeded through a problem, PBL students were encouraged to think about problems in the context of the underlying scientific principles, not simply as a set of features (“clues”) that lead to a solution.

Hmelo believed that the modeling that the facilitator presented could be a factor in the PBL students' success at problem-solving, and suggested investigating modeling as well as discourse learning and student-student instruction as factors.

Hmelo's first-year medical students were in the same category as the "novice" problem-solvers in the Patel, et al. study. The greater use of hypothesis-driven reasoning by PBL students in the Hmelo study agrees with the Patel et al. conclusions about novice learners under the "problem followed by science text" context. What is interesting here is that these "novice" PBL problem-solvers showed more improvement on accuracy and coherency than did the non-PBL students. While Patel et al. downgrade PBL students for using backward reasoning, that same reasoning served students well in solving problems in Hmelo's study. The study would need to follow the reasoning patterns of the students as they progress through their medical school career in order to make a full comparison with the Patel et al. study.

What happens when learners are truly novice reasoners, as when school children use reasoning skills to solve ill-structured problems? Petrosino (1998) examined reflection and revision skills and students' changing concepts about inquiry in a group of at-risk middle-school students engaged in a problem-based astronomy unit. Petrosino noted that in teacher-centered science classrooms, the bulk of classroom interactions is taken up with seatwork, with very little inquiry or experimentation. Labs tend to be verification or technical skill labs, which follow prescribed procedures. Petrosino proposed that classroom practices that highlight inquiry and scientific reasoning give students opportunities to reflect on their reasoning in the context of authentic problems, increasing

students' abilities to reason. "Hands-on" or "learning by doing" practices imply that physical manipulation of objects is sufficient; however, if such activities are short, rare, or unrelated, students gain little from them. A problem-based curriculum, on the other hand, increases the opportunities for students to work "hands-on," while engaging their reasoning skills around the materials they are manipulating.

The study involved 23 middle school students, grades 5 and 6, enrolled in an eight-week summer school session. Most of the students had failed their science coursework the prior school year. The summer course used a curriculum involving designing a mission to Mars, anchored with a "Mars Challenge" video. At the start of the course, students were challenged to think about the problems involved in planning a manned mission from Earth to Mars and back again. After watching the video, students assumed roles such as Medical Officer, Supply Officer, Designers, and others.

Part of the unit revolved around building model rockets, using the Estes™ "Big Bertha" kit, a rocket model that allows for design modifications, including various styles of nose cones. Students built and launched the rockets, recorded flight data, and analyzed the data on classroom computers. Students were to find ways to improve the design to achieve maximum height and performance. This engineering design problem served as a vehicle for teaching about inquiry for this study.

At the beginning course, shortly before the end, and several weeks after the course, students were interviewed to uncover their concepts of inquiry. Students were presented with contrived lab data and materials and were asked to make sense of the data and of the experimental logic. Students were given a story about a researcher who studied erosion,

and conducted experiments in which rocks were weighed before and after shaking in a tumbler. During the interviews, students were also asked to make hypotheses about the altitude of their model rockets related to the design, including the number of fins, painted or unpainted, and nose shape.

In the initial interview, only 16% of the students could figure out what the rock-tumbling experiment was about. Slightly over half of the students mentioned one variable, but could not relate the variable to a question. All but one of the students found it difficult to interpret the data. Overall, the students had difficulty relating the procedures of the experiment to relationships and occurrences in the natural world. The author concluded from initial experiments that the representational aspect of experimentation was a difficult challenge for the students.

As part of the Mars unit, students worked in design teams to design their rockets. They actively borrowed ideas from other teams, since this was not a competitive scenario and teams were encouraged to share information. The design-based goal of the unit gave students a strong motivation to collect and analyze data. The teacher coordinated the launches, and asked students to spend time before the launch reflecting on what data they would need to gather. The teacher also posted questions on the internet for students to answer, including descriptions of experiments that had been carried out incorrectly, which students were to critique.

As the course progressed, the author noted the students' discourse around the launches changed. At the initial launch, students described the activity as, "We're gonna shoot off some rockets." Several weeks later, students getting ready to launch were able

to give detailed descriptions of what they needed to do in order to collect necessary data. At one point, the students noticed another class preparing to launch model rockets, and asked them why they weren't measuring how high their rockets went, suggesting that the students in the PBL class had already internalized the need to collect data, and that there were aspects of model rocketry that were worth knowing.

The final interviews, conducted near the end of the unit and several weeks after the class in order to observe short-term retention, showed that most students had moved from direct observation of specific events to making inferences about relationships between rocket model features and the height the rockets reached. Complex design features, especially additive effects, were difficult to perceive. Students who had initially believed that multiple rockets were needed in case one broke later understood the need to compare experimental and control models. Students who initially believed that model rockets weren't of much value to learning about full-sized, working rockets moved to an understanding the utility of models in science and in engineering design. Few students at the start were able to suggest ways to refine an experiment to gain additional data. By the final interview, nearly all of the students interviewed were able to suggest ways to revise an experiment.

Petrosino concluded that middle-school students, even at-risk students with low scientific knowledge and low reasoning abilities, can learn about the nature of experimentation through guided practice. Students do not, however, acquire these skills simply from exposure to labs, especially labs where students carry out a prescribed procedure and then move on. The students in the study, when presented with a real-world

problem in a social learning context, were able to engage in spontaneous data-gathering and complex reasoning. There were limits, however, perhaps imposed by development, by lack of prior knowledge, or by the short time in which they were involved in the course. The students in the study by the end of the eight weeks still had difficulty relating multiple factors together in discussing what factors affected rocket performance.

The Westbrook & Rogers (1996) study on student concepts about floating, already described, supports the idea that development may be one limit imposed on younger students' abilities to reason around a problem. Students who were unable to mentally conserve volume were unable to discern the relationship between an object's shape and its ability to float. Students shaped clay into three shapes: ball, cube, and flat. Each time the clay sank. Had students thought to shape the clay into a boat, their final conclusions might have been different. These students believed that clay was too "heavy" to float, in spite of class discussions about water displacement, and so believed that clay would always sink. Their developmental level — concrete reasoning on a neo-Piagetian measure — limited their ability to grasp the concepts even in an inquiry-based, social learning context.

Model-based reasoning

Nersessian (1992; 1999) argues that hypothetico-deductive reasoning is not the only type of reasoning that scientists engage in, nor is it the only type of reasoning that results in scientific progress. Modeling practices and model-based reasoning are productive methods of scientific discovery and of conceptual change in science. Nersessian uses

Johnson-Laird's (1983) definition of a mental model in terms of an analogy, describing a mental model as a structural analog of a real-world or imaginary phenomena. As an analog, a mental model "embodies a representation of the spatial and temporal relationships among, and the causal structures connecting the events and entities depicted and whatever other information that is relevant to the problem solving task." While philosophy has traditionally embraced logic and deductive reasoning as the most significant path in scientific progress, hypothetical-deductive reasoning fails to fully describe and explain the creative reasoning processes that scientists and science students engage in.

Model-based reasoning encompasses the use of analogical reasoning, imagistic reasoning, and thought experiments which have played central roles in the construction of new scientific knowledge throughout the history of science. For example, Darwin's theory of natural selection as outlined in *On the Origin of Species* begins with setting up an analogy between the selective breeding of pigeons and the selective forces of nature. Niels Bohr created an analogy between planetary motion and the motion of sub-atomic particles in orbit around other particles in creating the Bohr orbital model of the atom. Faraday's images of lines of force around a magnet formed a central image in his reasoning about magnetic attraction. Thought experiments led Galileo to construct testable hypotheses about gravitational attraction, and were at the heart of Einstein's work on general relativity. While examples such as these are well documented, they have received little attention from researchers attempting to analyze the methods of science

(Nersessian, 1997). Yet the construction of analogies, images, and thought experiments remains at the periphery of philosophical discussions of scientific reasoning.

Driver, et al. (1996) developed a typology of student reasoning in science that described a hierarchy of reasoning skills that lead to model-based reasoning. The hierarchy is constructed of three reasoning types: phenomenon-based reasoning, relation-based reasoning, and model-based reasoning.

In phenomenon-based reasoning, inquiry is viewed as a process of observing and describing a phenomenon, either one encountered in nature or created in the lab. Student attempts at explanation take the form of descriptions, reiterating what was seen rather than hypothesizing about underlying mechanisms, nor is the student able to distinguish between a description and an explanation.

Relation-based reasoning occurs when students understand the need to control or plan observations, and when students attempt to correlate variables. Explanations take the form of descriptions of correlated features of a phenomenon, and students may choose one variable as a causative factor. The student distinguishes between observations and explanations, and views observations as “better,” because a theory can be “proven” through direct observation.

Model-based reasoning arises from mental models, constructions, and theories about a given phenomenon. Students recognize that the model or construction must be evaluated on the basis of empirical evidence, and that the relationship between evidence and model is fluid. Theories and models are conjectural, and explanations derive from a theoretical

position. In fact, an explanation need not rely on observations at all, but arise from a theoretical position.

Kawasaki, et al. (2004) used the Driver, et al. hierarchy of reasoning to examine the development of theory building and modeling among third and fourth-grade students. Using discourse analysis, the researchers examined transcripts of conversations with students who were engaged in a study on sinking and floating. The researchers worked with a classroom teacher in developing a curriculum based on research on children's development of the concept of density. Students worked in organized groups that rotated through three sets of three activities each. Activities involved ordering objects according to weight and volume, making predictions about whether given objects would sink or float and giving explanations for their predictions, testing predictions, then explaining the results. During the unit, students were introduced to the use of terms such as prediction and theory, using "theory" in terms of a broad explanation for many related phenomena that they observed.

At the start of the unit, the majority of students employed phenomenon-based reasoning, demonstrably unable to separate the concepts of observation and explanation. For example, one child, when asked for an explanation, referred back to prior experience with floating objects:

Teacher: Any other theories about why you thought something would
sink or float?

Ivan: We thought the wood would float because if you THROW a stick into the water it would go splash and then rise to the surface.

Teacher: So that's sort of like Zeke's theory about wood floating, or is that different?

Charlie: Kind of. A little.

Ivan: 'Cuz you can go throw sticks and they'll go straight under the water and then they'll just come shooting out.

Teacher: So you've seen wood float before.

Ivan: Yeah. (p. 1309)

While this was a developmentally reasonable place to start, students soon discovered that a reiteration of descriptions of observed objects floating and sinking never answered the question of *why*. Yet even when the difference between observation and explanation was made explicit by the researcher in conversations with students, many students still offered descriptions as explanations. Instruction from the teacher and correction from other students led to toward relation-based thinking. Because instructional expectations were clear, students knew they had to answer *why* questions with something other than further observations or experimental results, and strove to find an explanation. Further, students began to understand that they were seeking one explanation for all of the observations they had made:

Paul: Well, I think this was already said, but you didn't really have one theory for every single one, because you're supposed to have something like...

Mark: Mollie was saying something about how we had one theory.

Paul: Because you're supposed to have one theory for all six. (p. 1310)

Student understanding of the need for one unifying theory helped them move from relation-based to model-based reasoning. Student discussions that demonstrated model-based reasoning included the comparison of different theories to discuss their merits as explanations. For example, students often began with the idea that weight was a factor in whether something sank or floated. A weight-based theory was eventually discarded by most students on the basis of evidence, in favor of a density-based theory. Because the weight-based theory is compelling, some students continued to use it, either inadvertently from habit, because they were not yet satisfied with a density-based theory.

Hal: And it's fresh water so it'll...

Liz: And it weighs a little more, oh yeah, weight wouldn't matter.

Hal: And that was for the fresh water, so salt water would sink.

Mollie: It's going to float because...

Alan M.: If the paper clip is bigger and weighs more...

Leo: No, it doesn't matter about weight. It doesn't matter about weight.

Mollie: It's the density of it. (p. 1314)

By the end of the unit, students had a much stronger idea about scientific models and theories serving as conjectural explanations. They could form predictions about new presentations of phenomena, such as computer-based simulations of sinking and floating and representations of density, and apply their tested models to the new problems as they developed explanations based on their theoretical positions. Model-based reasoning does not imply that all students used the scientifically-accepted model; however, most students found that alternative models were less satisfactory as explanations for their observations.

That model-based reasoning can occur with alternative models was demonstrated in a study by Leite and Afonso (2004). In this study, 38 pre-service physical science teachers were assessed for their conceptions around air pressure. The teachers were given a survey which presented three scenarios related to air pressure: a balloon stretched over the mouth of a bottle, a burning candle under a bell-jar in a container of water, and an shelled boiled egg placed on the mouth of a bottle. In each case, the teachers were asked three questions about each scenario. Each question asked them to either predict, explain, or predict and explain the results of changes in the system if, for example, the bottle with the balloon were heated, or more candles were added to the bell jar, or the bottle with the egg were cooled. Teachers were asked to provide full written explanations for each of the questions.

The majority of teachers demonstrated model-based reasoning on the bottle-and-balloon questions, but relation-based reasoning on the remaining questions. However, not all model-based reasoning drew on scientifically-acceptable models. Mechanisms within model-based reasons offered by the teachers for the balloon problem included chemical reactions caused by the heat and forming hydrogen, and expansion of the particles themselves due to heat. Model-based explanations that involved kinetic energy of particles were closer to the scientifically-accepted model, but varied in the degree of completeness. A complete model, by the researcher standards, included air temperature, kinetic energy of particles, collisions between particles, a relationship between collisions and pressure, and the inflation of the balloon.

Transfer of reasoning skills

Transfer of knowledge, concepts, and skills is problematic at all levels of learning. Numerous factors can provide barriers to transfer, including the compartmentalization of knowledge into rigid subjects or disciplines, over-simplification of concepts, or presenting ill-structured knowledge as well-structured, as though all the questions have been answered. Some researchers, in fact, doubt whether transfer even exists, theorizing that knowledge is entirely context-dependent (Brown, et al., 1989). If PBL supports the development of concepts and reasoning skills, can its ill-structured problems, complexity, and social interactions also support transfer of reasoning skills?

Pederson and Liu (2003) examined the transfer of reasoning skills in 6th graders participating in a PBL unit, hypothesizing that PBL may help facilitate transfer, because

in PBL, knowledge is presented contextually and is usually not oversimplified. They also hypothesized that modeling a problem-solving process would help students learn the process and be able to transfer it more effectively. Students in three classes participated in the study, a total of 66 students.

The teaching medium for the unit was a program called *Alien Rescue*, a hypermedia program in which students take the role of young scientists aboard an international space station. Their job was to rescue alien life forms and place them in suitable worlds based on their life needs. Near the start of the activity, students received a distress call from an alien ship and, given what they learned about the six species of aliens aboard the ship, they had to find suitable planets and moons for the species to live on.

The program included an “expert tool,” with pop-up videos of an expert scientist engaged in the same task. Four videos corresponded to four segments of the program. Three versions of the “expert tool” were used: a modeling condition, in which the expert engages in think-aloud problem-solving using the tools available in the simulation; a didactic condition, in which the expert explained the tools and gave tips for using them effectively; and a help condition, in which the expert explains how to use the tools, but does not give advice on how to use them. A transcript of the expert video, however, showed that in the didactic condition, some scaffolding of the reasoning process behind choosing tools occurred as the expert explained what information was still missing. The three conditions were distributed randomly between the three classes participating.

Students worked individually at their computers to complete the unit, but were encouraged to share information. Social interactions around the unit were informal and sporadic. They worked on the unit daily for 45 minutes each day, for a total of 14 days.

Following completion of the unit, students were given a paper-and-pencil transfer problem. Students were asked to determine which of three locations would provide the best habitat for a species of endangered salamander that had to be moved from its native stream due to pollution. Students were given incomplete information and had to generate a list of questions regarding the information they needed to solve the problem. Separately, the researchers developed a model list of appropriate questions against which the student questions were compared. The next day, students were given answers to their questions. They then had to come up with a solution to the problem and give a rationale for their solution. The questions were rated according to their appropriateness to the problem. Rationales were scored according to the features relevant to the modeled method of problem solving, including supporting details, connection between details, and persuasiveness of the rationale.

The number of questions asked by students in all groups was nearly the same. However, both the modeling and the didactic condition significantly increased appropriate questioning over the Help condition. Modeling produced slightly more appropriate questions than the didactic condition, but not significantly so.

While both the modeling and didactic groups could ask useful questions, the modeling group had the advantage in developing a rationale for their solution. Scores for the

modeling group were significantly higher than the didactic group and the help group. The didactic group scored significantly better than the help group.

The authors concluded that learning information in the context of a PBL unit that included modeling of a problem-solving process increased student abilities to develop problem-solving skills and to transfer those skills to other problems. Modeling helped students develop appropriate questions and avoid irrelevant questions, and to link information together into a persuasive rationale for their problem solutions.

The authors recognized an important limitation to this study: the transfer problem was very similar to the *Alien Rescue* problem and was delivered immediately after the unit was completed. The problem was a case of near-transfer in the short-term, but tells the reader little about far-transfer and about the students' abilities to retain their problem-solving skills over longer periods of time. A longer-term study would be needed to determine whether problem-solving learned in a 2 1/2 week unit is retained for longer periods of time, and how these skills could be reinforced over time.

Transfer of reasoning skills in medical students was addressed in a short paper by Bédard, Tardif, and Meilleur (1996) as part of a longitudinal study on the development of reasoning skills in a PBL-based medical curriculum. Because the primary function of a physician is clinical reasoning, it is crucial that medical students develop sufficient proficiency with clinical reasoning that their reasoning skills can transfer from their training experience to their professional experience.

The authors followed six students for two years of their medical school training, beginning in their second year. In both years, volunteer students were given written

clinical problems to be solved, and were asked to carry out a “think-aloud” procedure as they worked. The volunteers were given several simple mathematics and geographic problems first, in order to practice the “think-aloud” protocol.

Following the protocol training, students were given a clinical problem to solve. Each unit of information in the problem, usually a sentence in length, was presented on a separate page. Information included the patient’s history and data from a physical exam, including lab work. Volunteers were asked to think out loud as each piece of information was presented. Their responses were recorded, then later analyzed for propositions and hypotheses.

The same problems were given to two experienced physicians who served as experts. These experts carried out the same think-aloud protocol, and their responses were analyzed. Results served as a template against which to compare student responses.

Both expert and student responses were analyzed for problem-solving protocols employed by the volunteers. The analysis categorized the range of concepts in the explanations and assertions regarding each concept, as well as a global description of the thinking processes that emerged, including any conclusions or explanations offered and hypotheses generated during the problem-solving process. Hypotheses, or preliminary diagnoses, were categorized for each segment of the problem to track how hypotheses changed as the volunteers were presented with new data.

Volunteers were able to transfer a hypothetico-deductive model of problem-solving from their pre-clinical training to the clinical problems. Among the hypotheses that the volunteers generated early in the problem was the principle hypothesis appropriate to the

diagnosis. Second year students, who were presented with a simpler problem than the third year students, identified the main hypothesis as the most probable hypothesis five times out of six. Third year students had more difficulty pinpointing the principle hypothesis out of multiple possible hypotheses, but their problem was more complex, and several hypotheses were appropriate.

The authors conclude that PBL serves as an appropriate and useful cognitive apprenticeship for clinical practitioners. Practice problem-solving during coursework allows students to develop and abstract problem-solving skills, which they can later apply to similar problems in a clinical or simulated clinical setting. However, the paper-and-pencil problem presented bore a close resemblance to the students' curriculum in that it was a simulated problem, not involving a real patient whose life may be altered by a misdiagnosis. Does performance on a paper-and-pencil problem, with its inherent detachment and abstractness, predict how a clinician will perform in actual clinical practice?

Emergent factors

Controversy exists around the significance of hypothesis-driven (backward-chain) and data-driven (forward-chain) reasoning. Patel et al. (1991) assert that backward-chain reasoning is associated with novice thinking, and forward-chain reasoning is associated with expert reasoning. Hmelo (1998) and Hmelo, et al. (1994, 1997) disagree. While forward-chain reasoning may be associated with expertise, backward-chain, or hypothesis-driven reasoning is a flexible tool that is appropriate to apply to problems

when the reasoner lacks data or is working in unfamiliar cognitive territory. Furthermore, hypothesis testing is a driving force in science. The use of more scientific knowledge in the explanations is an indication of coherence in the Hmelo, et al. studies, whereas Patel, et al. associated a willingness to explore ideas and make connections with a lack of global coherence. While Patel, et al. associate a switch from backward-chain to forward-chain reasoning with a move toward expert reasoning, an alternative explanation for these findings is that the subjects were not verbalizing or otherwise communicating their entire reasoning process. A strong knowledge base may allow subjects to completely internalize reasoning processes, so that the hypothesis-driven portion is far less evident to the researcher.

In younger students, development of reasoning skills can be facilitated through scaffolding, though it may also be limited by development. Petrosino's 1998 study showed that even at-risk students who had failed traditional science classes and had failed to develop an understanding of the reasoning process within their lab experiences were able to increase their reasoning ability and their understanding of inquiry within a task-based science course that involved design and problem-solving.

While transfer of reasoning skills is problematic, modeling of the reasoning process and scaffolding within activities can help with transfer (Pederson & Liu, 2003). As students gain further practice in problem-solving, they increase their ability to abstract the problem-solving skills and apply them to other problems (Bédard, et al., 1996).

Metacognitive skills

Related to the development of reasoning skills and self-motivated learning are metacognitive skills — the ability of students to consider their own thinking and learning, to recognize their own thought processes, and to recognize what they do not know and need to learn. Three papers in this section describe how students' metacognitive skills developed within problem-based curricula.

Shepherd (1998) employed a problem-based teaching method to facilitate the development of critical thinking skills and metacognitive skills in elementary school students. Shepherd developed the method, termed the Probe Method, and used it in a 4-5 blend classroom during a social studies unit. Using the Cornell Critical Thinking Test as a measure of critical thinking skills, Shepherd compared the critical thinking skills of students in two classrooms: one employing the probe method, and one employing a didactic method.

Two teachers volunteered for the study; one whose classroom served as a control condition, the other who was trained in the Probe Method for two weeks before the unit began.

The Probe Method was an intervention designed to facilitate student thinking about an ill-structured problem. Using the method, the teacher guided the students through the process of:

- Identifying the problem.
- Introducing issues related to the problem.
- Understanding the complexity of the problem.

- Determining multiple factors that may influence the problem.
- Reading and collecting information on factors related to the problem.
- Discussing information gathered.
- Critically analyzing information gathered in small groups.
- Summarizing the most important information.
- Presenting the information to larger group.
- Reading and collecting additional information as needed.
- Discussing new information.
- Discussing possible solution.
- Summarizing in written paper the solution selected.

The researcher observed the experimental class each day that the Probe Method was being used to observe how it was actually implemented, and made frequent observations of the control classroom to record activities that the students were participating in.

Both classrooms were engaged in a 9-week unit on architecture. The experimental classroom was given an additional question: “How can we provide suitable housing for all the people in the world?” Students broke into groups to research different assigned countries, using the Internet and print media as sources of information. The control classroom studied architecture without a problem question, and was taught using lecture, small group activities, project work, reading, and writing assignments. Students worked both independently and in small groups to complete assignments. As they gathered data, they recorded their findings in journals and posted some of the information on an online bulletin board that the researcher maintained.

Statistical analysis showed no significant difference between the two groups of students on the CCTT prior to the 9-week unit. Following the unit, comparisons of pre- and post-tests showed that while the control group had no significant gains, the Probe Method group showed a significant increase in their critical thinking skills as measured by the test ($p = .001$). A t-test also showed a significant difference between the control and the experimental groups on the test, with the experimental group scoring significantly higher ($p = .0032$).

Observations, and analysis of student assignments, journal entries, and bulletin board entries, showed that students were confused by the method at first, and were often unsure of what they were supposed to write down. Some Probe activities had to be modified because of the difficulty level, such as searching the Internet independently. Students also took more time than was expected to find data. The teacher helped facilitate data gathering by creating a data sheet to help focus student efforts at the beginning. As students collected their initial data, they reported their findings on the online bulletin board, and contributed to a class home page with links to sites they'd found useful. This assisted other students, and the synergy created by mutual support increased the efficiency of data gathering as the unit proceeded.

As students proceeded through the unit, their journal reflections revealed that they found the problem to be more complex than they'd realized at first. They expressed a new-found appreciation for the complexities of a world-wide housing problem. Student CCTT scores supported these data, leading to the conclusion that students were developing better critical thinking and metacognitive skills through problem-solving.

One confounding factor to this study, however, was guided student use of the Internet. Students in the control classroom did not use the Internet to gather data. Students in the experimental group not only collected information from the Internet, but also communicated with the experimenter and each other via a class web page, and used the Internet to assist one another by posting helpful web sites. Availability of networked computers put a larger body of information at the fingertips of these students, and the resulting increase in information-gathering may have contributed to the results. However, this may reflect what other studies have found: that problem-solving ability rests depends in part upon the learner's knowledge pertaining to the problem.

As another means of examining metacognitive effects, Hueston, Mallin, and Kern (2002) examined learning issues that were generated during problem-based learning among medical students. Learning issues are those questions and statements that students generate as guidelines for their study and their investigations. An examination of student-generated learning issues gives some insight into student awareness of their own knowledge and what knowledge they believe they need to acquire in order to solve the problems presented.

The study was carried out at a medical university where the curriculum requires students to complete 4-week clerkships in family medicine. At the time of the study, one of the clinical sites was preparing to alter the curriculum, from a didactic, lecture-based curriculum to one involving a series PBL cases. Students had already chosen their clerkship sites among several clinical sites offered, and did not know that one offered a

new PBL curriculum. Throughout the year, students rotated through the sites, gaining clinical experience and knowledge in different settings.

The students at the study site attended a reduced number of lectures, and were presented with five required PBL cases and a sixth optional case. Students worked in groups with a tutor to diagnose their cases.

Most of the students involved (90%) had received a traditional, lecture-based medical school curriculum prior to their clinical experience. A smaller group had spent their first two years in a parallel curriculum that included PBL modules.

Data were collected for every rotation through the study site during one academic year. As students worked on solving their cases, faculty tutors collected the learning issues that students generated and forwarded them to the authors.

Analysis showed that most learning issues dealt with diagnostic questions, as might be expected given that the cases were all clinical problems involving diagnosis of a patient's symptoms. Subcategories within the diagnostic questions did not change significantly over time.

Two issue categories that did change significantly were those related to scientific questions and those related to medical decision-making issues. Students in the earliest rotations tended to create more learning issues around questions of scientific knowledge than students in the last rotations. The opposite trend was seen with medical decision-making issues. These were less common learning issues in the early rotations, and more common in the later rotations, either because the issues were not addressed, or because students became more aware of decision-making issues as they gained experience in the

clinical settings. The change for both types of issues was very small, however, and the low numbers of students involved must be considered.

While Hueston and colleagues examined third-year medical students, another study by van den Hurk and others (2001) looked at first-year medical students and examined the quality of learning issues that these students generated. For learning issues to serve as guides for problem-solving, the issues must be formulated such that they provide direction for the inquiring student, and suggest the extent of the study that must be conducted in order to understand the problem. The authors, drawing on prior research, determined that a useful learning issue 1) contained a keyword pointing to the topic to be studied 2) is formulate concisely and clearly and 3) is unambiguous for all members of the group.

Learning issues were collected from medical students during their first two tutorial meetings in a PBL course. One student in each group was asked to write down the issues students generated and agreed upon during the problem-solving sessions. The issues were then analyzed for the three qualities that the researchers had determined were key. As part of the analysis, students who had already completed the course were asked to rate the issues, and their scores were averaged.

While the learning issues generated increased slightly in quality from the first problem to the second, overall the quality of the learning issues was low. Individual issues did not usually, however, score low on all three qualities at the same time. Most issues contained a keyword, but in some cases a keyword was all that was provided. Conciseness and unambiguity were the most difficult qualities for first-year students to

capture, indicating that their ability to formulate sophisticated questions had not yet developed and that they were not skilled as self-directed learners. These students did not have prior experience in a PBL curriculum, which may have contributed to their lack of ability to form well-structured questions.

These findings were echoed in Hmelo, et al. (1997), where first-year PBL students tended to produce fewer hypothesis-driven learning issues than second-year PBL students. The second-year students relied entirely on hypothesis-driven learning issues to drive their explanations of further research. Furthermore, PBL students were more likely than non-PBL students to use a wide variety of learning resources to address their learning issues. Non-PBL students tended to turn almost exclusively to diagnostic handbooks in order to diagnose a case. PBL students were more willing to expand their learning around the case.

Emergent factors

The more experienced students are with problem-solving, the more aware they become of the complexities of a problem and the better they become at making decisions about gathering information. The elementary students that Shepherd (1998) studied were as capable as the medical students in the Hueston, et al. (2002) study and the Hmelo (1997) of increasing their ability to see the complexity of the problem and increase their critical thinking skills around problem-solving.

Practice also changes the focus of student awareness around the problem. Early in their experience with PBL, the medical students in the Hueston, et al. (2002) study

focused more on scientific knowledge, but as they gained experience, their focus shifted to problem solving, i.e. medical diagnosis with an increased awareness of the complexities of the problem.

Student concepts about electricity

Electricity is difficult for all learners to understand. Electricity itself is an abstraction, and involves multiple abstract concepts relating to molecules, electrons, potential energy differences, and similar concepts that are unfamiliar to most people. Learners who are new to a subject usually approach the subject with concrete thinking; hence many learners, and many science curricula, approach electricity with a concrete model of fluid flowing through tubes or hoses. While this model helps students make successful predictions about simple electrical circuits, it can introduce or support alternative conceptions that give students misleading ideas about electricity and electrical circuits that can affect their reasoning about complex circuits and the components of a circuit.

This section does not include an exhaustive list of papers on electrical concepts, as that would become overly repetitious. Instead, using several important articles as a guide plus additional supporting research, this section will review what is known about student alternative conceptions around energy, current, and electrical circuits.

Energy

Underlying the concept of electricity is the concept of energy. Students often use the terms “energy,” “force,” “electricity,” “power,” and “current” interchangeably (Watts &

Gilbert, 1983; Shipstone, 1985; Trumper, et. al., 2000), indicating an intuitive sense that electricity has something to do with energy, though students may be unclear about the relationship. Therefore it is worth examining student concepts of energy, as these may influence student ideas about electricity.

Watts (1983) carried out an interview study in order to describe concepts of energy held by nine students ages 14 through 18. All students had taken general science, and the older students had taken physics. Watts used a set of picture cards that included a human figure pushing a box uphill, a test tube in which a chemical reaction was taking place, a melting cube of ice, a battery, bulb, and switch in a circuit, a power station, and a human figure seated at a table eating a meal. Students were asked whether any of the pictures illustrated their concepts of energy, and to explain why. Most students believed that at least some of the pictures, but not all, showed energy, and all held at least some alternative conceptions regarding energy. Watts categorized their responses into a series of eight frameworks, which have been used by later researchers as well:

Framework 1: Human-centered energy. Energy is associated mainly with humans, and descriptions are largely anthropomorphic. For example, one student said about the picture of the human figure pushing a box up a hill: “The person’s got a whole lot of energy in that one... but, er, once the box is there it can’t *do* anything so the box definitely hasn’t got any energy... whereas the person can walk away back down.

Framework 2: Depository model. Watts also refers to this as the “source of force” model. In this model, students describe some objects as having energy or “force”

and having the capacity to be recharged with energy, and others needing it.

Energy in this model is a causative agent. One example of a student quote that expresses this model is, “Well, the battery’s *got* energy and the bulb *needs* it, and the wires... well, they’re just ordinary wires, aren’t they?”

Framework 3: Energy as an “ingredient.” Here energy is seen as dormant ingredient inside of things and needs a trigger to release it. Students speak of energy less in terms of storage and more in terms of reactions that trigger its release. For example, students may speak of food giving a person energy when it is eaten, or may argue that energy is not stored in coal but is “sparked off” when the coal is burned.

Framework 4: Energy is obvious activity. For many students, movement is strongly associated with energy. An object that is “just sitting there,” in the student’s mind, has no energy, while a falling object or a moving person does. Students who indicated that the chemical reaction had energy focused on the solution bubbling and frothing as evidence of the presence of energy.

Framework 5: Energy is a product. Unlike views that energy is an ingredient or process, some students saw it as a short-lived waste product. One student remarked about the picture of the chemical reaction, “They [the chemicals] might change... in which case they’ll release some of their energy and produce heat.”

Framework 6: Energy is functional. Here energy is viewed as fuel, but with limitations. Most students restricted their concepts of energy to technology, such as the power station or descriptions of appliances, where energy was seen as the

fuel to run electrical appliances. Energy is also viewed in a framework of utility, as in this response to the question of whether the box, in the drawing of the figure pushing a box, has any energy: “No, because the person’s doing all the work pushing it upwards... if *that* had any energy it could help him.”

Framework 7: Flow-transfer model of energy. In this model, energy is seen as a kind of fluid. Students uses terminology that is common in scientific textbooks, wherein energy “flows,” is “put in,” “given,” “transported,” “conducted,” and so on. This model was strongly associated with electricity.

Scientific model: Energy is a construct, a relationship within physical phenomena. It is often described as the ability to do work, a phrase that probably had a strong influence on students who exhibited Framework 6. The scientific model is so purely abstract that it should not be surprising that students use more concrete explanations.

A 1985 study by Bliss and Ogborn on energy concepts in 13-year-old girls supported Frameworks 1 (“human-centered”) and 4 (“activity”) in Watt’s model. The students were shown a series of pictures that included a growing plant, a man playing soccer, a radiator, a room, a sailboat on the water, a girl eating, a lighted lamp, a statue, a television set, and a train in motion. They were asked if energy were needed in any of the subjects pictured. The word “need” in the question could have been problematic, and may have influenced some of the responses, as the authors noted in the article, surmising that the wording of the question may have affected students holding the “activity” framework who believe

that the activity itself produces energy (in this mindset, the soccer player does not “need” energy, he creates it). The subjects viewed animacy as important when deciding what things “needed” energy, and animacy took precedence over movement. Things that were alive were perceived as needing energy, including the potted plant, which did not display movement. All students described the statue as not “needing” energy, because they are not alive and do not move.

Eleven of the 25 students interviewed chose the plant as “needing” energy, and of these, six spontaneously named the sun as the source of energy. All but one of the remaining five named the sun when asked for a source of energy, though students may also include soil and water as source of energy that are needed for growth, where growth is seen as the primary function for which plants need energy.

Students who selected inanimate objects as needing energy divided their ideas of energy between objects that radiate heat or light and those that “just work.” Hence the radiator and the lamp were viewed as needing energy, while the television and the radio were not.

Similar results were found in a cross-grade, cross cultural study by Liu and Tan (2004), who looked at concepts of energy among students in grades 4, 8, and 12 in Canada and China. Students were asked to respond in writing to two open ended questions, one asking students to list terms that they thought were related to energy, and the other asking them to write sentences clarifying the meaning of terms and relationships between terms. While the authors used their own coding scheme, the categories were similar to those of Watts (1983): energy related to human needs, as human strength, as a

source, as a flow of fuel, as an ingredient, as motion, existing in different forms, as a measurement unit, as something that can be transformed, as a potential ability or capacity, and energy conservation. The additional categories were implemented to categorize scientifically-acceptable models as well as alternative models.

In both countries, the majority of students at all ages understood that energy had different sources, which the authors equated to the “depository” model. Students also recognized that energy came in different forms. Older students in both countries used a flow or “fuel” model to describe energy. Older students were also inclined to discuss energy as the cause of movement or change. Very few students described energy as the potential or capacity to do work, despite the fact that physics is part of the national Chinese curriculum starting in grade 8.

The majority of Chinese students equated energy with human strength and potential, particularly in grade 4, while fewer than 22% of Canadian students used this model. There was a slight decrease in the number of Chinese students from grade 4 to grade 12 who equated energy with human activity, but this was in part because there was such a high percentage of students in grade 4 who thought in these terms. Only grade 12 Canadian students were likely to describe energy in terms of units of measurement. Grade 12 Chinese students were more likely than any other category of students to discuss the transformation of energy from one form into another.

Longitudinal analysis showed very little change in alternative conceptions about energy. The idea that energy is related to materials that are “used up” (the “ingredients” framework of Watts) increased among Chinese students from grade 4 to grade 8. The

concept that energy can be transformed or conserved dropped slightly for all students across the grades, and both concepts were held by only a minority of students.

Most students demonstrated a mixture of scientific and alternative conceptions. Even when concepts changed, the change was not a wholesale exchange of alternative for scientific views. Parts of the student explanation might change from an alternative to a scientific model, while other parts may remain firmly in place.

Trumper, Raviolo, and Shnersch (2000) applied Watts' frameworks and the pictures from the Bliss and Ogborn study to a cross-cultural study comparing energy concepts among preservice primary school teachers in Israel and Argentina. Besides looking at the picture cards, subjects were also asked to write their first three associations with the word "energy" and to write sentences linking those associations to energy, and to predict the height reached by a ball released on a frictionless roller coaster.

In general, all students confounded the concepts of energy, force, electricity, heat, light, power, and current. The "depository" and "product" frameworks were most commonly held by all subjects, and most of the subjects viewed energy as a kind of material. However, there were interesting cross-cultural differences as well. Most Israeli teachers associated energy with movement, while most Argentinean teachers did not. Most Israeli teachers spoke about energy being needed to do something, while most Argentinean teachers did not. Most Israeli teachers did not believe that energy was limited to living things, while most Argentinean teachers strongly associated energy with animacy. Israeli teachers were more likely to reject the degradation of energy and believe

that energy is conserved in energetic systems, while Argentinean students accepted the idea during the science course but appeared ambiguous about it in the interviews.

The authors cited several factors that may have resulted in these differences. First, the Argentinean teachers in the study lived near a nuclear power plant, and often engaged in discussions of energy sources and energy conservation, as well as discussions about the plant itself. In the interdisciplinary science course in which all the Argentinean pre-service teachers were required to enroll, students were exposed to topics that were not in the Israeli curriculum, including the use of energy in daily life, conservation of energy (in terms of “wasting” or “not wasting” household energy sources, which could influence their ideas of energy degradation), the potential energy of inanimate objects, and energy transformations, including photosynthesis.

Trumper (1998) also looked at Israeli preservice teachers, but took a longitudinal view. Students were enrolled in a 4-year preservice program for future high school teachers. The subjects were 25 students who intended to be high school physics teachers. At the end of the program, students received a B.Sc. degree in Physics and a teaching certificate. Students were assessed for their concepts of electricity at the end of each year, using the illustrated cards used by Bliss and Ogborn (1985), and questions about a jumping bug toy used in a study by Gilbert and Pope (1986). Watts' (1983) framework was used to categorize student concepts.

Most of the students in the first year had concepts of energy as a substance or a concrete entity rather than an abstraction. Most also held the idea that there must be

movement for energy to be present (“activity” framework), and that energy is needed to do something (“functional” framework).

Over the course of the four years, there was a significant shift away from the “activity” framework and toward a model that recognizes that different bodies possess or store energy. Students also showed a trend toward a model of conservation of energy, with 32% describing energy as conserved in the first year to 72% in the fourth year. However, the idea of energy as an abstraction remained very low throughout all four years. The number of students who rejected the “activity” framework went from 4% in the first year to 44% in the fourth year. However, students who accepted the “functional” increased from 16% in the first year to 52% in the fourth year, possibly because of learning the familiar concept of physics, that energy is the capacity for doing work. There was very little change in the number of students who equated energy with force, nor was there significant change in the number of students who believed that energy as found only in living things. The number of students who demonstrated this framework were very low throughout the study.

Ebenezer and Fraser (2001) and Liu, Ebenezer, and Fraser (2002) examined concepts of energy in college-age first-year chemical engineering students. In interviews in both studies, students were shown beakers of different substances: sodium chloride, sodium hydroxide, sodium thiosulfate. The interviewer added water to each beaker and asked the student to hold it, so that each student felt whether there was a temperature change. Sodium chloride exhibited no discernible change, while sodium hydroxide was strongly

exothermic and sodium thiosulfate was strongly endothermic. Students were asked to explain what was happening.

Student ideas about energy in chemical solutions fell generally into four categories:

- 1) People supply the energy (by stirring)
- 2) Water gives off energy
- 3) Salt gives off energy
- 4) The reaction gives off energy (Breaking bonds takes in or gives off energy, forming bonds gives off energy. No students stated that forming bonds used up energy.)

Most students identified energy as “the ability to do work” and stated that energy is converted, can exist in different forms, and cannot be destroyed, all conforming to textbook definitions and expressed in terms close to a scientifically acceptable model.

But in regards to the solutions themselves, half of the students believed that energy to break bonds in salt crystals came from water, that water has energy, that adding salt “activates” the energy, and that it was the “activated” energy that broke apart the bonds in salt. Though the researchers used a phenomenological perspective and did not categorize the responses by a pre-existing coding scheme, these students showed a strong association with Watts’ “depository” and “ingredient” frameworks.

Also, despite recognition of vibrations of atoms, students did not believe that there was any kinetic energy in crystal lattices, but that kinetic energy was released when the bonds were broken.

Finally, researchers found that students did not use consistent models of energy across all three tasks. They viewed each task as a separate phenomena, unrelated to the others. Most students, in fact, used an entirely different model or combination of models to explain energy in the three different solutions.

The researchers proposed that using student models in the chemical engineering curriculum could help overcome students' confusion, if instructors made explicit the commonalities between exothermic and endothermic reactions. Students who look at the macroscopic level see three different reactions: no change, solution gets hot, solution gets cold. Instruction that looks at the three reactions at a molecular level could be used to point out the consistencies between the three seemingly different reactions.

Electrical current

Though students encounter electricity in their daily lives, few hold a scientific view of what electricity is or what it does. Most students hold one or more of a variety of alternative conceptions. Yet when it comes to making predictions about the behavior of components in a circuit, some of their alternative models work, leading them to predictions that prove to be correct (Andre & Ding, 1991). This is why moving students from alternative models to scientific models can be so difficult: observation of electrical circuits may reinforce some alternative conceptions.

Because most studies in this review examined multiple concepts around current and circuits, this section is divided into conceptual categories, with information from each paper divided between appropriate categories.

Concepts of current

The terms “current,” “electricity,” and “energy” are often confounded or used interchangeably by students across various studies (Shipstone, 1985). Students often take a material view of electricity, believing that electricity is a kind of fuel that emerges from the battery and that is “used up” by various components of a circuit (Osborne, 1981), leading to alternative concepts of current in electrical circuits.

Young students, who often equate “electricity” and “current,” appear to view current as a kind of substance that is stored in a battery, and hence the unipolar, or linear, model of a circuit as described by Osborne and Freyberg (1985) seems perfectly plausible. Students demonstrate a unipolar model when they attempt to connect a bulb to a dry cell with a single wire, viewing the dry cell as a source of the substance they call “electricity” or “current.” If getting that substance from the dry cell to the bulb is all that is needed, the unipolar model proves adequate. The model carries over into everyday experience: when shown a picture of a light socket that has no bulb, but only two bare wires sticking out of it, many children believe that there is “current” in the wires, because a person can still get a shock by touching them (Osborne, 1981). Some think that current “leaked” out of the wires, while some believe that “currents” flow around in the ends of the wires. Young children have considerable experience with electrical household appliances that, to a

child's view, have one wire coming out of them that is plugged into an electrical socket; hence a single wire connecting bulb and battery makes sense.

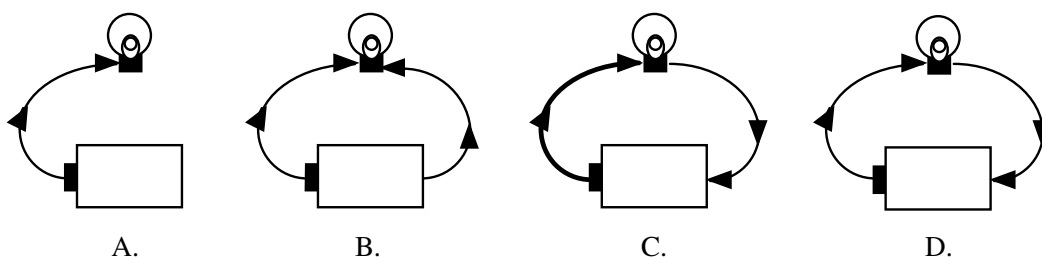

Figure 3: Osborne and Freyberg's (1985) models of current in simple circuits. A. Unipolar, B. Clashing Currents, C. Attenuation, D. Scientific.

Shipstone (1984, 1985) adds a fifth model, a Sharing model, which applies to circuits with several bulbs or other components connected in series.

Direct experience with wires, bulbs, and dry cells is usually adequate to dispel the unipolar model. On first experience with constructing circuits, students observe that wires must connect a bulb and a dry cell in a circular arrangement in order for the bulb to light up. However, their models of what actually happens in the circuit may explain what they see, but may be far from a scientific model of current. In a child's view, the circular nature of a circuit is what allows the perceived substance in the battery to "flow."

Osborne and Freyberg (1985) describe four models of current in a simple circuit (Figure 3), which have been supported by other researchers (for example, Butts, 1985; Psillos, Koumaras, and Tiberghien, 1988; Dupin and Johsua, 1987) to which Shipstone (1984, 1985) adds a fifth:

- 1) The Unipolar model, a linear model in which one wire is thought to be adequate to connect the dry cell to the bulb. Osborne (1981) notes that while experience shows students that a second wire is necessary, students often believe that the second wire does not play an active part, or serves as a “safety” wire. This is still in essence a unipolar model.
- 2) The Clashing Currents model, in which students believe that “something” (electricity, current, energy) moves from both the negative and the positive poles into the bulb and creates a reaction, causing the bulb to light.
- 3) The Attenuation model, in which students describe “something” moving in a circular path from a dry cell, through a wire, to a bulb, and back to the battery through a second wire. Students believe that the “something” moving through the wires is “used up” by the bulb, so there is less coming back from the bulb than there is going in. This is reinforced by their experience with common dry cell batteries: they know that the batteries weaken over time and have to be replaced, leading to the conclusion that something in the battery is used up or drained away.
- 4) The Shared Current model, which Shipstone describes, applies to circuits with more than one component, such as two more bulbs in series. In this model, “something” flows through all components of a circuit and is shared between all components (such as multiple bulbs in series), but is consumed by the components.

- 5) The Scientific model, in which current flows in one direction around the circuit, but is conserved.

These alternative models are not limited to younger students, however. All of these are common sense models that function to explain what can be observed in simple circuits and everyday experiences with electrical appliances. Through experience and teaching, students may learn more scientific models, but even science teachers may retain some of the more compelling concepts about current. Pardhan and Bano (2001) carried out a study on science teachers and found that all the teachers in the study held reasonably scientific views of some aspects of current: that current is the flow of electrons, that an electric circuit is a complete path for the flow of electrons, and that current flows from the positive pole of a dry cell through a circuit to the negative pole. However, a number of alternative conceptions were uncovered. About one-third of the teachers believed that current was “used up” by a bulb, and used similar language to indicate that they held an attenuation model of current. Most teachers thought that “resistance” meant that electrons slowed down or that some opposing force had been applied in the other direction. One-third of the teachers also believed that the more bulbs that were added to a series circuit, the more electrical current passed through the circuit because the bulbs “needed” more current.

When asked where their ideas had come from, teachers reported learning these some of concepts as physics students, while others were learned from life experiences, metaphoric use of terms, and from the physics textbooks used in class. The authors found

that the text that the teachers were using contained several alternative conceptions, so it is not to wonder that the teachers and the students, accepting the book as authoritative, accepted these alternative views.

In examining where students, teachers, and electrical engineers get their ideas about electricity and what models they employ, Stocklmayer & Treagust (1996) found that a fluid transfer model of electricity is used almost universally among science teachers and is quickly picked up by science students. While it is considered an effective model for teaching, and helps create metaphors that students can apply to real circuitry, most teachers recognize that a particulate model, which is also commonly used in high school textbooks, is more correct. Shipstone (1985) also notes that the majority of students interviewed use the flow of water as a metaphor to describe electricity. Interestingly, though, the electrical engineers who were interviewed used neither model, and saw electricity as “a field-like phenomenon, formed of endless loops.” The electrical experts considered the micro-view of electron transfer as too confusing.

The role of the battery was also problematic for many students. Cohen, Eylon, and Ganiel (1983) found that most high school students thought that the battery was the source of current, and that “current” was something material or quasi-material that was stored in the battery. Though they had been introduced to voltage in terms of the potential difference between the poles of the battery, they thought that the potential difference was the result of current and not its cause. Pardhan and Bano (2000) found that many physics teachers also saw the battery as a current-storage or electron-storage device, and that the current (or electrons) were used up over time.

Current in simple circuits

Discovering student conceptions about current in circuits presents several challenges. Vocabulary can be one barrier. Because students often use electrical terms such as current, electricity, force, and energy interchangeably, it is often difficult for researchers to discover what meanings the student applies to these terms (Shipstone, 1985). Another barrier is student understanding of the equipment used. Andre and Ding (1991) found that undergraduate college students who were unfamiliar with the inner construction of light bulbs, which might describe most students, were unable to create a working circuit when given a dry cell, two wires, and a bulb. This failure to produce a circuit was completely dissociated from the students' mental models of current and circuits.

In order to investigate the effects of the stimulus conditions of the study on student responses, Andre and Ding presented a series of tasks in which students were asked to create a circuit. The conditions ranged from a dry cell, one wire, and a bulb or buzzer, to a bulb in a holder with two obvious terminals, a dry cell in a holder with two obvious terminals, and two wires. The authors found that where two terminals were present in the components, the task was easier regardless of the models students held. Two visible terminals on the bulb holder seemed to suggest a simple one-to-one correspondence in students' minds with the two terminals on the dry cell, and they quickly connected the terminals with wires. Where buzzers were used, though, each end of the buzzer had to be connected to the correct pole of the dry cell in order to function, making the task slightly more difficult. On the "easy" conditions, students could apply any model of circuits

except a unipolar model and get a satisfactory result. On the “difficult” conditions (such as a bulb without a holder), even students with a scientifically accurate model might not be able to complete the circuit if the students did not know where the terminals were located on a bulb.

Thus direct experience does not always eliminate an alternative conception. As Shipstone (1985) notes, students who hold the clashing currents model can connect a dry cell to a bulb and produce a working circuit, thus confirming their mental model. Didactic instruction is usually required to replace the clashing currents model with one more scientifically acceptable.

Because the scientific view of current in simple circuits is difficult to form from hands-on experience, it is not surprising that some alternative conceptions around electricity are difficult to change. However, repeated instruction does make a difference. Shipstone (1984) examined student concepts around circuits in a study that incorporated middle school and high school students. None of the students used a unipolar model, suggesting sufficient experience with electrical circuits to know that the model did not work. Younger students in the study were more likely to use a clashing currents model than older students who had received more instruction. The attenuation model was also reduced, but by far less, as students tend to hold onto the attenuation model when describing the role of components in complex circuits, reinforced perhaps by their everyday experience with “dead” batteries and “burned-out” light bulbs.

Schauble, Glaser, Raghavan, and Reiner (1991) carried out a deeper analysis of students’ conceptions of individual components in a simple circuit, creating a hierarchy

of descriptive models of student views of electrical components and how they interact. The authors gave volunteer college students a “black box” task. They were shown small, unlabeled plastic boxes, each of which contained some part of a circuit. They were also given bulbs as current indicators, a board with sockets for a bulb and connector pins, and wires with connector pins for connecting the boxes with the board. Their task was to determine the identity of the unknown components, then to sort them into baskets labeled, “large battery,” “small battery,” “large resistor,” “small resistor,” “plain wire,” or “nothing,” and explain their reasoning.

Student models about the components and circuits in general varied according to two key factors. First was their beliefs about the objects of a circuit and the way in which those objects function. Students had several alternative conceptions about batteries and resistors that directly affected their views about what was in the boxes. Second was their ideas about interrelationships between components and what causes and effects were at work, as some students had difficulty talking about how one component might affect another.

From student explanations, the authors described four “levels” of understanding:

Level 1 — Simple local models (5 of 22 students) : a component worked or it did not work. Students did not go on to explain the functions of each component. They used only one “black box” component at a time. A typical conclusion was that batteries “worked” and other components did not. If the subjects did add more than one component, they focused on one component at a time and did not talk about how one component might affect another. These students

focused on positive outcomes: making the bulb brighter. They did not demonstrate the concept that one or more variables might dim the bulb.

Level 2 — Main and auxiliary additive causes (2 of 22 students): Students described two types of components: those that “work” and those that “help.” Resistors, wires, and even the empty box were regarded as conduits or “pipes” to help the batteries light the bulb. These students believed that causes sum to produce an effect, but one cause was considered the main cause and others were thought to be auxiliary. These students, as did the Level 1 students, focused on positive effects.

Level 3 — Additive causes plus negation (12 of 22 students): Students recognized both positive and negative outcomes as possibilities: a component can make the bulb brighter, dimmer, or fail to change it. This allowed students to recognize the role of resistors. Students named four functions for the four types of unknown parts; however, some students thought that the empty box was a kind of resistor, since they saw a resistor dim the bulb, then the empty box put it out completely, so they saw it as the same kind of function. Level 3 students didn’t recognize interactions between components. For example, they thought that a medium resistor should produce a particular bulb brightness, regardless of what else was in the circuit. Function of parts was interpreted relative to the perceived purpose of the system (teleological explanation).

Level 4 — Causal system (3 of 22 students): Students recognized that any outcome depended on the interaction of all variables in the circuit. They also

recognized that bulb brightness was not just an effect of the components, but also the wattage of the bulb, so that if they changed the bulb, the brightness might also change.

Models for more complex circuits

Shipstone (1984) notes that while students can generally master the basic principles of simple circuits, given instruction, complex circuits remain problematic. Students tend to analyze the components of a complex circuit separately and in sequence, again applying the attenuation model to their thinking: that is, those components that come “first” in the circuit use up more “current” than those that come later. They will often predict, for example, that in a circuit containing three bulbs in a series, that the first bulb will be the brightest and the last will be the least bright, regardless of any prior experience with everyday complex circuits, such as holiday lights. The attenuation model is also applied to resistors, and students assume that a resistor “uses up” the current, leaving less available to the circuit.

How these models change with age and experience was the subject of a cross-age study by Dupin and Johsua (1987), who examined concepts of complex circuits in students ranging from age 12 to college age. The subjects were given a multiple choice questionnaire which assessed their knowledge of current, and asked them to make predictions about changes to circuits.

The authors found that the attenuation model was highly persistent, strongest in the younger students, and persisting in about one-third of the college students. The authors

propose that the cognitive constructs that students form as they work with electrical equipment may be barriers to further understanding. The attenuation model seems logical and seems to “work” for students in spite of the fact that actual experience with models creates a cognitive conflict when students see that identical bulbs in series do not show varying brightness. Under instruction, students employ a fluid model for current. With persistent instruction, students learn and accept conservation of current. However, they improperly generalize conservation and perceive the battery as a current generator, delivering a constant current regardless of what components are in the circuit.

McDermott and van Zee (1985) examined college students’ concepts in explaining complex circuits. Only one-quarter of the undergraduate students in the study used a scientifically acceptable model to explain current in a simple circuit. The majority used an attenuation model, describing “current” or “electricity” as a material that is “used up,” and this had a direct effect on their concepts of current in complex circuits.

When making predictions about the brightness of bulbs in a complex circuit, acceptance of an attenuation model strongly affected the results. Most students predicted that the arrangement and order of components had a direct effect on other components or on the current in ways that contradicted actual results. For example, students predicted, as noted in Shipstone (1984) that the first bulb in a series would be the brightest because it “used up” most of the current. One task, in which students were to compare a single bulb in a simple circuit with two bulbs in a series circuit and two bulbs in a parallel circuit, only 15% predicted the correct relative brightness of all bulbs. The 243 that did not generated 30 different orders of brightness for the bulbs in the three diagrams, and most

of the explanations involved language around how components used up current. Adding ammeters or voltmeters to the arrangements or to written tasks did not help and was, in fact, problematic, because students were unfamiliar with the instruments and did not know how to interpret them. They also had a very weak grasp of the concept of voltage.

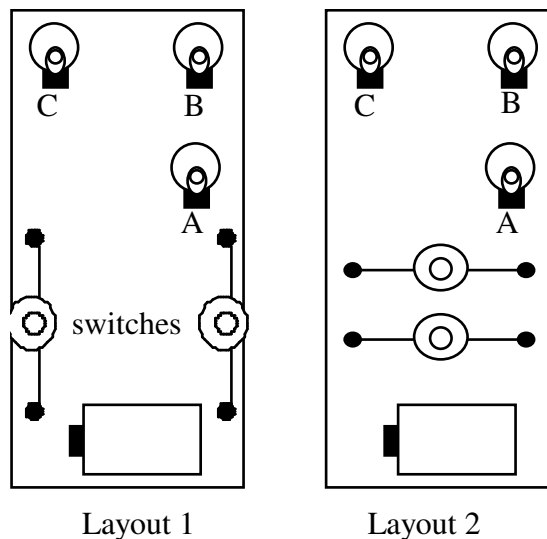

Figure 4: The Doll's House task, adapted from a diagram in Duit (1985).

In the task, subjects were asked to make bulbs A and B light up simultaneously when one switch was flipped, and C light up separately when the second switch was flipped.

The complexity of the task also had an effect on student success. Duit (1985) gave elementary students who were studying electricity the task of wiring a set of lamps for a doll's house. In the task, subjects were given a board with three bulbs, two switches, a quantity of wire, and a dry cell. Their task was to wire the board so that two of the bulbs lit up at the same time when one of the switches was flipped, but that the third would

light up separately when the other switch was flipped. Two different arrangements of the boards were used, as show in Figure 4.

Regardless of the board arrangement, none of the students in the study was able to successfully complete the task. The most common strategy was to link both switches and all bulbs in one series circuit. Some students wired the switches in parallel and the individual bulbs in parallel as well. In one such arrangement, the battery became warm when the bulbs were not glowing, indicating a short circuit across one switch, but the student could not apply that knowledge to correct the circuit.

Voltages in circuits

Few studies have been done on voltage, either as a concept in and of itself or within a study of other electrical concepts. In studies that have been done, however, the universal conclusion is that students of all ages do not understand voltage.

Psillos and Koumaras (1988) examined concepts of voltage in students ages 14-15. Students were given a simple questionnaire in which they were asked which of several terms was most familiar to them (volt, kilowatt, KWh, Ampere, Coulomb), and examples where they had seen the term “volt” used.

Students were most familiar with the terms “volt” and “kilowatt.” Most students knew that batteries carried labels indicating voltage, and that the term “kilowatt” appears on electric bills.

However, in trying to explain what “volt” meant, students demonstrated that though they had seen the term many times, they had little or no conception of its meaning. Most

students defined voltage either as the “something” that the battery contains, or as a unit of measurement of electricity, energy, or current, though they did not elaborate on these terms. Some students suggested that “voltage” indicates how much energy, current, or electricity various machines either have or consume. Some viewed voltage as the force, strength, or power, or the current or electricity that is generated in a circuit.

The authors suggest that students are far more familiar with current than they are with voltage. Most school curricula introduce electrical current before voltage, leading students to view current as the primary concept. Most curricula use a fluid model to explain current. Students learn this concrete model as the primary model of electricity. When voltage is later introduced through relationships with other variables, students view it as an elaboration, something “extra,” and do not grasp its significance. Because voltage is introduced in the context of batteries, students associated it primarily with battery terminals, and the view voltage as a property of batteries. In some cases, students view voltage as the result of current instead of voltage driving current. The authors propose that voltage should be introduced first as a primary concept in order for students to form a better understanding of the relationship.

Cohen, et al. (1983) also found that students believe current is the primary concept, and that voltage is merely a consequence of current rather than its cause, if indeed students distinguish between voltage and current at all. Shipstone (1984; 1985) found that most students confuse the two terms, and may believe that voltage is either a measure of current or is another word for current. Shipstone also noted that voltage is introduced later in the curriculum, while current is usually introduced very early. Students apply

what they know about current, correct or incorrect, to the concept of voltage, and they have great difficulty applying the fluid model of electrical current to understanding potential differences.

Emergent factors

Most students at all levels of education, including engineering majors, hold alternative conceptions about electricity. Many of these conceptions arise from instruction, when fluid-based models of current in electrical circuits are introduced. As useful as the fluid model is for understanding the effects of current and making predictions about the functions of components in a circuit, the model can create or reinforce a concept of electricity as a material, fluid substance, which can lead to alternative conceptions about simple circuits and incorrect predictions about complex circuits.

Students have considerable trouble making correct predictions about complex circuits. Their common sense understandings about how electricity works tend to lead them astray, particularly if they hold an attenuation model, in which electricity is “used up” by the components. The model is supported by their everyday experiences in which batteries are “used up,” and electric bills charge the household for electrical use, suggesting that the household has “used up” some quantity of electricity. Even when confronted by circuits in which the attenuation model does not hold, students tend to cling to the model because, in the view that electricity is a material substance that is consumed, the model makes sense.

In reasoning about circuits, most students have difficulty in relating the components to one another. Students tend to view each component as a separate entity, each with its own function, and have difficulty predicting how the function of one component may affect the functioning of others. Experience with electrical circuits may help circumvent this difficulty, as students become increasingly familiar with the functions of the separate components.

Chapter 3: Design and Method

The purpose of this study was to examine student conceptions of energy, electricity, and current in simple and complex circuits, voltage, and resistance as they entered a task-based learning environment, and how their prior knowledge interacted with their reasoning skills as they worked to solve the problems that the tasks presented. The study will contribute to an overall model of how students use their prior knowledge to reason within task-based learning environments and how, in turn, reasoning within a task affects their concepts.

Design of the Study

Context: TekBots™ program model

The TekBots™ program is a hands-on robotics learning platform used in the Electrical Engineering and Computer Science (EECS) Department at Oregon State University. Beginning in their freshman year, EECS students purchase the basic TekBots™ kit, consisting of a small wheeled platform on which students assemble the electrical components that make the wheels turn and that allow the student to control the robot's movements in various ways. The robot contains a motor control analog board, a charger board, and a sensor board. Students enroll in laboratory courses, beginning with ECE 112, where they work with the TekBot™ platform, adding components and

capabilities to their TekBot™ robot. By the end of the term in ECE 112, the first term in which students use the TekBot™ robot, students assemble a robot that can steer around obstacles that it bumps into by sensing the obstacles with whiskers. In lab, the final assembly was referred to as a “bump bot.” As an optional project, students can construct a “photovore,” a robot that senses and follows a light source, and can be guided through a maze using a flashlight. Each lab that uses the TekBot™ platform is aligned to the lecture topic of the week, so that students have the opportunity to apply the knowledge that was presented in lecture.

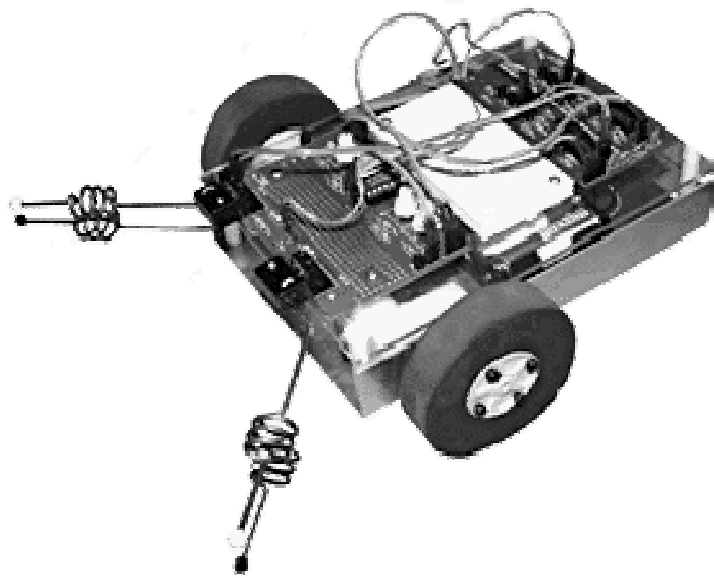

Figure 5: An assembled TekBot™ robot with optional whiskers

Use of the robot continues throughout their undergraduate career. As they advance through the program and learn more complex engineering principles, they apply the new principles to new problems of adding more capabilities to the robot, thus connecting theory to practice and forging links between various courses. Upper-level students serve

as mentors to freshmen in the 100-level laboratory courses, which helps reinforce prior learning for the older students, and helping orient newer students to the task-based nature of the course.

A photo of an assembled TekBot™ robot is shown in Figure 5.

Context: ECE 112 course description

Students first use the TekBot™ robot in ECE 112: Introduction to Electrical and Computer Engineering, taken in winter term. The course follows on ECE 111, taught in fall term, in which students are introduced to the school of engineering, learn how to solder circuits, and construct a small circuit board. Most, but not all, of the students in ECE 112 have taken ECE 111 the prior term.

In the lecture portion of the ECE 112 class in this study, students reviewed basic concepts of electrical circuits and apply concepts of voltage, current, and resistance to more complex problems. The term concluded with an introduction to digital logic. The lecture portion of the class included traditional didactic lecture, discussion, and small-group work on in-class problems, two in-class exams, and a final exam. Students were expected to download and read class notes and diagrams before lecture. During the lecture, the instructor elaborated on the class notes, guided students through solving problems on the notes, and went over homework problems.

The lab portion of the course consisted of five labs, four of which required two weeks to complete. Most students had sufficient time in lab to complete the exercises, though some students took their work home or attended a weekly make-up lab to finish their

work. Students worked from instructions in a lab book that they downloaded from the course web site. Two to four upper-level and graduate teaching assistants were present during lab to assist students, but otherwise students worked on their own or in pairs to complete the exercises.

The sequence of lecture and lab topics is outlined in Table 1.

Participants

The subjects of this study were purposefully selected from first-year engineering students enrolled in ECE 112: Introduction to Electrical and Computer Engineering, who were engaged in a project-based lab involving the TekBots™ platform, where they were to apply their knowledge of electrical systems to a series of tasks, and solve problems as they worked to troubleshoot their systems. From a pool of volunteers out of the total class, twelve case study subjects were selected, and seven completed the study. Using demographic data from a concept survey handed out on the first day of class, and the results of the survey, the group was selected to include male and female students, students from underrepresented groups, and students scoring at the high and the low end of the total range of scores.

Table 1: *Topics and concepts covered during the lecture and lab portions of ECE 112.*

Week	Lecture topics	Lab Activities
1	Electrons, electricity, conductors Electrical current vs. conventional current Voltage and electromotive force Schematic diagrams and symbols	Lab 1: Learning to Solder Students begin the initial assembly of the TekBot robot platform
2	Independent voltage and current sources Ohm's Law (current = voltage/resistance) Resistors in parallel and networks Calculating power dissipation Nodes, loops, and branches in complex circuits.	Lab 2: Battery charger and Base Assembly Students assemble and test the battery charger. By the end of the lab the battery pack should be correctly connected to the wheel mount and should power the robot wheels. Students learn to use a multimeter to measure current and voltage. Concepts encountered: current, voltage, voltage regulator, voltage divider, Ohm's law, fuses, diodes.
3	Kirchoff's Voltage Law Single-loop circuit analysis using KVL Voltage dividers	
4	Kirchoff's Current Law Circuit analysis using KCL	Lab 3: Theoretical Exercises Students use the robot platform and a prototyping board to carry out a series of exercises to help them understand basic electrical principles.
5	Circuit elements Computer-based KCL analysis Diodes, zener diodes, and capacitors	Concepts encountered: passive sign convention, voltage, resistance, parallel and series circuits, power generation and dissipation.
6	Bipolar junction transistor (BJT) Using the BJT as a switch	Lab 4: Motors, BJT's, and Diodes Students apply what they have learned about voltage, current, resistance, BJT's, and diodes to create automatic switches that can be used in the motor control board to cause the robot to stop, go forward, or reverse, and to create an amplifier.
7	BJT DC and AC amplifier Regulated power supply design	
8	Analog to digital conversion Binary logic concepts and circuits Digital logic design	Lab 4: Comparators Students apply what they have learned about voltage, current, and digital logic to constructing a circuit with a comparator that will control the "bump bot" behavior. As an optional project they can construct a "photovore" that follows light.
9	Reduction of logic using K-Maps	
10	Class overview and evaluation	Optional project lab

Theoretical framework

Phenomenology as a research perspective

Student perspectives on electrical concepts were examined in terms of the students' experiences of electrical phenomena and the relationship between each student and the subject across time. This non-critical, subjectivist approach calls for a phenomenological perspective. The purpose in choosing this perspective is to allow for a rich description of student ideas in the described context without labeling their perspectives as "right" or "wrong," and without categorizing them into a hierarchy ranging from "completely wrong" to "completely right." Rather, student perspectives were described and viewed in their relationship with student reasoning and approaches to problem solving.

Phenomenology has become so widely embraced by philosophy and social sciences, and so many variations have arisen, that the term by itself has become diluted (Patton, 2002). For the purposes of this study, phenomenology is defined as an inquiry paradigm, as described in Lincoln (1990), while Moustakas' (1994) take on phenomenology as a research methods framework and Roth's (2005) studies of perception using cognitive phenomenology shaped the perspective on data gathering and analysis.

Lincoln (1990), in a discussion of the ethics involved in qualitative research, categorizes phenomenology among systems of inquiry where the researcher's goals are one set of needs that drive the inquiry, but not the only set. The inquiry ends are jointly and cooperatively determined by the inquirer and respondents, a mindset removed from the view of research that is something "done to" the subjects. In phenomenological

inquiry, both researcher and respondent are co-participants in the inquiry, and both come away with information that they did not have before.

Roth (2005) describes using a phenomenological perspective in several research studies involving students carrying out tasks to learn scientific principles. In many cases, students either interpreted the results of the activities along non-scientific principles, or failed to notice details that the teacher had thought were important. While observers and educators may attribute the results to student misconceptions, misunderstandings, or even deliberate laziness, Roth sought an explanation from the learner's perspective, framing the research questions along the lines of, "Why do students see the events in the way they do, rather than, for example, the way I see them?" and "Why do the students not arrive at seeing the events after following the teacher's instructions?"

Moustakas (1994) developed a research framework grounded in Husserl's (1913) transcendental phenomenology and involving the concept of intentionality, which indicates the orientation of the learner's mind toward the object. The challenge of this approach lies in integrating two concepts, the *noema* and the *noesis*. *Noema* is essentially a mental schema, the person's perception of and awareness of objects in the world, both real and imaginary. *Noesis* refers to acts of consciousness, what the mind does in response to the world, including the explicating of what the subject is experiencing, how it is that they are experiencing, and the person's beliefs regarding an object. *Noema* refers to the objects, content, or phenomena to which the *noesis* is directed. Both are intertwined in a complex relationship that creates intentionality. The challenge for the researcher lies in discerning the *noema* and *noesis* as held by the learner. To do so

requires a process of “bracketing” a person’s assumptions about the external world, beginning with a position of *epochè*, from the Greek word meaning to refrain from judgment. *Epochè* means to put aside everyday understandings and meaning and to view the phenomenon from a pure or transcendental ego — hence Husserl’s term transcendental phenomenology. *Epochè* is the process by which the researcher attempts to set aside biases and prejudices, or at the least become aware of these viewpoints and make them clear. From this stance, the researcher then “brackets” the subject matter as much as possible on its own terms, by first searching the data for key terms, phrases, and statements relating to the phenomenon in question, interpreting the meanings of these phrases, returning to the subjects to obtain their interpretations of the phrases, searching these meanings for what they reveal about recurring features regarding the phenomenon, and offering a tentative statement regarding the phenomenon in terms of these perceived meanings.

Phenomenography as a research tool

Growing from the phenomenological perspective, phenomenography developed as an approach to educational research, primarily by Ference Marton and colleagues at Gothenburg University in Sweden (Liu, et al., 2002). Phenomenography as a methodology focuses on student perceptions of natural phenomena, and variations between student’s conceptions within a group of learners. This can enable teacher-researchers to sort student conceptions into mutually-exclusive descriptive categories that may then inform later lessons (Ebenezer & Fraser, 2001). Categories of description may

also be used to drive curriculum development, and to inform curriculum writers as they work to move students from their personal outcome space into a zone of proximal development as described by Vygotsky (1968).

Marton and Booth (1997) described phenomenology as a perspective in which student conceptions are defined not as solid mental representations or structures existing within the learner's mind, but rather the student's experience of a phenomenon, described in terms of a relationship between that person and the specific subject. Four fundamental assumptions support this perspective:

- 1) As individuals reflect upon a phenomenon, they conceptualize about that phenomenon in a limited number of qualitatively different ways.
- 2) Conceptions that are expressed may reflect differences between two or more individuals, or they may reflect differences within an individual.
- 3) Variations observed within and between individuals can be described by a limited number of categories.
- 4) Categories thus described for a complex system, termed the "outcome space," the goal of phenomenographic analysis.

In this framework, a "conception" is defined as two dimensional. One dimension focuses on the content of the subject, which may be termed the referential aspect. The second dimension refers to how the learner understands the content, which is the structural aspect (Ebenezer & Fraser, 2001). In this study, for example, the referential aspects include "energy" and "current in electrical circuits," while the structural aspect is

“the students’ conceptions of energy, and of current in electrical circuits.” The learner’s conception of any given phenomenon is provisional, and qualitative. As the learner gains knowledge in a particular domain, there occurs a qualitative change to the student’s understanding of the phenomenon as understanding grows deeper and more complex. Part of the qualitative change includes a change in the learner’s perspective, which in turn changes the thinking and understanding of the concept. Learning is more than acquiring knowledge. Learning alters the internal relationship between the learner and the world.

Phenomenographic analysis of student knowledge is a hermeneutic process. Phenomenography seeks to explore student conceptions of a phenomenon, derive descriptive categories from student data, and, if appropriate, order the resulting categories into a conceptual hierarchy (Ebenezer & Fraser, 2001).

The process begins from a position of *epochè*. Student statements and other recorded data are read repeatedly to discern patterns in the responses, with no preconceived categories. Rather, the responses are interpreted according to how individuals themselves perceive the phenomenon. The researcher then constructs categories of description incorporating a range of conceptualizations in an attempt to understand the students’ statements and use of terms, and relating each category to the others and to the whole. Theoretical validity may then be constructed by comparing student statements to an established conceptual structure, such as a scientific explanation for a phenomenon. The discerned variations in these conceptions form the “outcome space” for the phenomenon. The categories of description are grounded within the context under research and characterize the person-world relationships within that context. However, it is possible,

depending on the responses, to transcend the context from which the responses arose.

(Ebenezer & Fraser, 2001; Roth, 2005)

Identifying cognitive effects

Key to understanding learning within a task-based context is a system of identifying cognitive effects from student data. Within this study, two types of cognitive effects will be traced: conceptual change and reasoning strategies.

Conceptual change

Though a great deal of literature exists on creating conceptual change, it can be difficult to find within these studies an explicit definition of what the term means. Implicit in conceptual change studies is the notion that students beliefs, ideas, assertions, or mental models around a concept change, partially or fully, permanently or temporarily. It may be practical, however, in designing a study to trace conceptual change, to establish a working definition of the term.

Linder (1993) identifies two broad classifications of conceptions as depicted in the literature: a *mental model* perspective and an *experiential* perspective. The mental model perspective views conceptions as tangible constructs within the learner's mind, made up of structured propositional patterns of reasoning. A wide range of literature embraces this view (for example, Vosniadu and Brewer, 1994; Samarapungavan & Weirs, 1997), and seeks to change mental constructs by means of adding to the internal structure through acquisition of new knowledge, reorganizing the internal structure through reorganization

of existing knowledge, or discarding parts of the internal structure through challenging existing knowledge in a way that assists students in rejecting that portion of that knowledge. This perspective is grounded in psychological literature on concepts and natural categories, in which most domains of knowledge (such as color or form) are structured into non-arbitrary semantic categories (Rosch, 1973) that tend to be consistent between learners and even across cultures. However, the boundaries between categories may be fuzzy, particularly where category members are atypical (*dolphin-mammal* as opposed to *dog-mammal*, for example), which leads to idiosyncrasies between individual learners and differences between some standard set of knowledge (such as scientific knowledge) and individual knowledge (McCloskey & Gluksberg, 1978). The mental model perspective implies conceptual stability, which is supported by research suggesting that student conceptions tend to resist change (for example, Posner, et al., 1982; Gunstone, et al., 1992).

The second perspective, the experiential perspective, derives from phenomenography research, including Marton (1981) and Marton and Booth (1987). In this perspective, conceptions are viewed as *categories of description*. Unlike the natural categories concept, categories of description are entirely idiosyncratic, and arise from person-world relationships in which one does not simply conceptualize, but one conceptualizes about *something*. This does not preclude internal representation; rather, it seeks to describe individuals' varying categorical descriptions without imposing *a priori* assumptions about the nature of the categories. Within this perspective, conceptual change refers to a changing relationship between a person and a context. Changing that relationship implies

not just changing the structure of knowledge, but that one has changed as a person. Unlike the mental model perspective, the experiential perspective does not imply conceptual stability. Rather, the relational dimension implies constant conceptual variability. This is supported by the “knowledge in pieces” perspective of diSessa and others (for example, diSessa, 1982; diSessa & Sherin, 1998), in which a “concept” may be a “concept of the moment,” assembled for the researcher from the learner’s current pieces of knowledge, termed “phenomenological primitives,” or *p-prims*.

For purposes of this study, the experiential perspective was employed. Though categories of knowledge regarding energy (Watts, 1983) and electricity within circuits (Osborne and Freyberg, 1985) have been established, this study seeks to understand how students themselves describe their views of energy and electricity before deriving descriptive categories, and seeks to understand how these perspectives change as students grapple with new knowledge and experience the outcomes of the application of their knowledge to a problematic task.

Understanding the context within which students use and apply their knowledge is important as well. As Linder (1993) points out, without context, it is unreasonable to cast judgment on whether concepts are appropriate, correct, legitimate, “alternative,” or any other designation. For example, a fluid model of electrical current may, in the context of a fully scientific explanation, involve incorrect conceptions of electricity as a physical substance, and might be deemed an “alternative” conception. However, within the context of introductory physics and electrical engineering courses, the fluid model is frequently used to help students understand how electrical currents cause particular

effects. In this context, it may be unreasonable to call student use of the fluid model to explain circuits or to predict effects “alternative” or “unscientific” when they have been encouraged to think in those terms. Therefore the context in which students obtain their knowledge and the relationship between student knowledge and the learning context must be an important part of this study.

Reasoning strategies

A traditional view of reasoning involves employing inductive or deductive algorithms to propositional sets. The notion behind this view lies in soundness of the ultimate conclusion, supported by and reached through a set of true premises by way of good reasoning. By starting with maximally probable premises, and using a correct logical algorithm, a person should be able to reach maximally probable conclusions (Nersessian, 1998).

However, applied to science, the traditional view of logic and reason arrives at certain shortcomings. Good reasoning with a set of presumably correct premises can still lead to incorrect solutions. Earlier views of science, in which it was believed that the entire world was rational and that all of nature could be understood by logic, frequently led to conclusions that were at odds with later observations. Modern science proceeds using a variety of tools in addition to reason, including analogy, thought experiments, and pure serendipity. There is, in fact, little classical logic to much of scientific discovery (Nersessian, 1999). At the heart of modern science and engineering is the development of models, and reasoning that takes place in developing and using models, where *model*

refers to a representation, physical, mathematical, or mental, of some aspect of the natural world, and embodies a selected set of assumptions about the object or phenomenon and hence can exhibit some of the properties of the modeled object or phenomenon (Lee, 1999).

A functional model of reasoning within science is described in Nersissian (1999): a cognitive model of reasoning by way of mental modeling. This derives from psychological literature on semantic reasoning, which plays a larger role in human reasoning than the traditional inductive-deductive models allow (Craik, 1943). Vandierendonck and de Vooght (1996) also argue that humans tend to solve problems, including simple logic problems, by constructing mental models in memory rather than using classical rules of argument. Nersessian proposes a hypothesis regarding model-based reasoning:

That in certain problem solving tasks humans reason by constructing an internal model of the situations, events and processes that in dynamic cases provide the basis for simulative reasoning. Whatever the format of the model itself, information in various formats, including linguistic, formulaic, visual, auditory, kinesthetic, can be used in its construction.
(1999, p. 12)

Traditional accounts of reasoning do not support conceptual change; indeed, the traditional account supports the belief that conceptual change cannot be arrived at by

reason, but is a mysterious process occurring through flashes of insight. Nersessian, however, argues for an explanation of conceptual change through the problem-solving process. Records of these processes can embody practices that constitute forms of model-based reasoning, including analogical, visual, and simulative modeling. Protocols developed by cognitive psychologists, employing “think aloud” processes echo historical examples of insight and conceptual change through extensive journaling, which constitutes a “think aloud” process on paper. Darwin’s journals are a well-known example. Chi, et al. (1989) and Chi (1992) use student self-explanations and “think aloud” methods as a means of tracking student reasoning and conceptual change. Analogic modeling, visual modeling, and thought experiments all reveal the learner’s reasoning processes, at the same time revealing present conceptions and conceptual change. Reasoning and conceptual change are, in this model, intertwined, and reasoning consists largely of the application of current concepts to a specific problem.

Sorting the reasoning process from the conceptual change process requires tracking of explicit or implicit *if-then* propositions. *If* a certain statement about electricity is proposed by the learner to be true, *then* a set of stated conclusions or enacted behaviors will result. For example, students may use their conceptions about electrical current to make predictions regarding the function of a circuit when particular components are assembled in a particular way. Students may express their reasoning through analogies (such as the fluid model), by visual models (such as sketches), or by thought experiments in which the *if-then* propositions are made explicit.

Driver, et al. (1996) developed a protocol for identifying model-based reasoning in student explanations. This was first developed for studies on student views of the nature of science, and was used to analyze student statements about scientific reasoning. This protocol was originally used by Driver et al. to describe student perceptions of scientific statements; that is, what kind of statement did a student consider to be scientific?

However, the protocol is also useful for describing changes in student theory building and reasoning; for example, Kawasaki et al. (2004) employed the protocol to categorize and compare student responses as they carried out activities to understand sinking and floating, while Leite & Afonso (2004) used the protocol to analyze prospective science teachers' reasoning around the concept of air pressure. The protocol describes a hypothetico-deductive relationship between descriptions (observations) and explanations (inferences), in that in model-based reasoning, a learner begins from a theoretical standpoint in providing an overall explanation for observed phenomena. For example, in a unit on sinking and floating, a student using model-based reasoning might begin with a statement about density, then use that theoretical position to explain why certain objects will sink or float. Thus model-based reasoning is not used instead of hypothetico-deductive reasoning; rather, hypothetico-deductive reasoning is one component of model-based reasoning. Driver's typology is summarized in Table 2.

Table 2: *Typology of characteristics of student epistemological reasoning about scientific concepts. Adapted from Driver et al., 1996.*

Form of Reasoning	Form of scientific inquiry	Nature of Explanation	Relationship between explanation and description
Phenomenon-based	Focus on the phenomenon: Inquiry is the process of observing an event or causing an event and observing what happens.	Explanation as description: an explanation is the same as a description, and further explanations consist of descriptions of further examples.	No distinction: A description is no different from an explanation.
Relation-based	Focus on correlation of variables: Interventions are designed to elicit phenomena that can be used in constructing an explanation.	Empirical generalization: Explanations involve causative or correlational relationships between features of a phenomenon.	Inductive relationship: A description is subordinate to an explanation, but both are subordinate to observations. Observations can “prove” hypotheses. Explanations are generalizations from data.
Model-based	Evaluate theory: Theories and models are evaluated using empirical evidence. Theories and models are fluid and changing.	Modeling: Theories and models are conjectural, and multiple theories may be supported by data. Explanations arise from a theory or model.	Hypothetico-deductive relationship: An explanation can arise from a theoretical or inferential position rather than direct observations.

This study focused on one category in this typology: “Nature of Explanation.” This was most easily derived from student conversations in lab and in the interviews. From transcripts of students working in lab, it was possible to determine whether student explanations were simply restatements of the observations (“You add more resistors and the current decreases.”), whether students offered causative explanations (“The resistance is higher in the circuit, so that’s why the current decreased.”), or whether they referred back to models or explanatory theories they had seen in lecture (“Resistance restricts the flow of current, so increasing resistance should decrease the current.”). Further analysis

of the data at a later time may yield more information on the other two categories of reasoning.

Method

To reiterate from the introductory section, the goals that drove this research and provided the guiding questions were:

1. To document, analyze, and trace changes in students' conceptions and reasoning for students with low prior knowledge and students with high prior knowledge while students are engaged in a project-based engineering laboratory.
2. To compare conceptual changes and reasoning between students who enter the program with strong knowledge of energy, electricity, and circuits and students who enter with weak knowledge.
3. To observe and document learning that becomes meaningful for students and changes in the body of meaningful learning throughout an electrical engineering course in order to test and refine the proposed model of task-based learning.

To develop and guide the research and data-gathering process, these goals were operationalized into a set of initial guiding questions, which determined the procedures at the beginning of the study:

1. What phenomenological categories of common knowledge regarding direct-current electrical circuits do the observed first-year electrical engineering students construct?
2. What relationship exists between these student's prior conceptual understanding of electrical circuits and the student's reasoning processes while solving problems involving circuits?
3. How does meaningful learning among these students change as they grapple with a series of complex problems?

During the course of the study, however, the research questions changed as new observations suggested other factors that influenced student reasoning and student behaviors in lab. This was not unexpected; indeed, Lincoln's (1990) heuristic approach to phenomenological research employs the use of questions that emerge from the data.

Themes and changing questions arose within the themes defined by the research goals:

1. *Phenomenographic categories of knowledge*: The survey instrument and interview protocols used to describe subjects' knowledge arose from the literature on student conceptions of circuits, current, and the small amount of research on voltage and resistance. In addition, students revealed a number of concepts around the function of batteries and bulbs within the circuits, and their expectations regarding the behavior of branching circuits, which reflected underlying understandings of current and had consequences in lab. This question was later

framed as: What phenomenographic categories of common knowledge regarding current, voltage, resistance, batteries, and bulbs are constructed by first-year electrical engineering students? In addition, what models of simple and branching circuits do these students tend to employ in their explanations?

2. *Reasoning and student prior knowledge*: Based on prior research in problem-based learning, it seemed reasonable to predict a relationship between student reasoning during problem solving and student prior knowledge. However, other factors emerged that may be important predictors of student success in the course and appeared to influence student reasoning. The second question, then, broadened into: What factors influence students' reasoning processes while solving problems involving circuits?
3. *Meaningful learning*: The expectation raised by Bransford, et al. (1993) was that meaningful learning would be a growing body of knowledge that students add to each time they work on a new task. However, it became evident early in the study that meaningful learning may instead be a fluid body of knowledge that is highly context-dependent, and may change quickly even while a student is working on a problem. The third question, then, inspired a set of questions around meaningful knowledge: What is the nature of a student's meaningful knowledge? What influence does context have on meaningful knowledge? What factors activate knowledge and make it meaningful?

Data collection

Phase I: Participant selection

The subjects for this study were selected from First-year engineering students enrolled in ECE 112, which requires enrollment in a project-based laboratory (TekBots™)

On the first day of class, a survey of electrical concepts was administered to all students as a pre-test (see Appendix A), which was used as a sorting tool to sort students into categories of low, moderate, and high knowledge. The pre-test consisted of a set of questions on DC circuits from the concept test described in Mazur (1997) and questions drawn from McDermott & van Zee (1985) and Shipstone, (1984). The survey included a small amount of demographic data, including gender, ethnic background, other courses students had taken where they encountered electrical concepts, and any experience they had outside of school with electrical systems, including hobbies or “tinkering” at home. The survey began with having students draw a simple circuit that included a bulb, a dry cell, and wire, and explain what it is that causes the bulb to light. It was not expected that a large number these students, who were already interested in electronics, would show alternative models of a simple circuit; rather, the question was a useful beginning for discussion of electricity and simple circuits during the later interviews.

The questions that followed were multiple-choice questions involving concepts of current, resistance, and complex currents. After each set of choices, students were given space to explain their responses. The first questions in the survey were designed to elicit ideas about simple circuits with bulbs in series and parallel. While students may have

encountered these in prior classes, it was expected that some students might hold alternative models about how these circuits function. Questions that followed included concepts of resistance and voltage. The expectation was that these would be more problematic for students, especially those who had little or no prior experience with electrical systems, either at school or at home.

The results of the survey were reported back to the instructor at his request. From the surveys, those from students who indicated willingness to participate as case study subjects were scored. Responses in which the circled choice and the written explanation matched scientific concepts were given a score of 2. Answers in which the student circled the scientifically acceptable response, but showed an alternative explanation in the written response, or failed to give a written response, or put “I don’t know,” were scored as 1. A score of 0 was given to answers where the circled response was not the scientifically acceptable response, and the written response was also contrary to a scientific explanation, or was absent. The top score possible was 24.

The signed consent form that was distributed and collected included a checkbox for students who wished to volunteer to be observed and interviewed. Nineteen students volunteered. Volunteers were then sorted according to whether their scores fell at the high end, the middle, or the low end of the range. From these pools, students at the high and low ends were selected and contacted by email to ask if they were still interested in participating. Those who still agreed were contacted again to set up appointments for the first interviews and to set up a schedule of observations. Seven students took part in the

initial interviews, and all seven completed the study. The seven subjects, identified by initials, are listed with their demographics in Table 3.

Table 3: Subjects selected for the study, identified by initials, their gender, stated ethnicity, prior coursework in which they recalled learning electrical concepts, prior experience in working with electrical systems or electronics, and the score on the survey out of a possible 24.

ID	Age	M/F	Ethnicity	Prior coursework - electrical concepts	Highest math level	Prior experience	Survey score pre/post
A M	19	M	White, American	Physics	MTH 252: Integral calculus	Built computer	6/15
YZ	18	M	Chinese national	None	MTH 252: Integral calculus	Built computer	6/11
MJ	23	F	White, American	None	MTH 256: Applied differential equations	None	8/16
KR	19	M	White, American	Electrical exploratory Physics	MTH 252: Integral calculus	Electronic hobbyist	14/14
JF	24	M	White, American	None	MTH 105: Intro to contemporary mathematics	Construction work	15/24
AK	18	M	Asian American	Physics	MTH 255: Vector calculus	Built computer	20/21
TA	29	M	White, American	Naval electronics courses	MTH 256: Applied differential equations	U.S. Navy Electronic hobbyist	23/24

Phase II: Describing student's initial concepts and reasoning

In order to describe student's initial concepts, survey forms for the seven case study subjects were set aside and analyzed to form initial hypotheses about the mental constructs students were using as they thought about the circuits presented on the survey. Because some students provided very little in the way of written explanation to go with their choices of answers, these initial hypotheses were tentative, and were tested in the initial conceptual interviews.

Initial conceptual interviews: All case study volunteers took part in the initial interviews during the third week of the term. Interviews were videotaped for later analysis. Because the interviews could not take place until the third week due to scheduling and technical difficulties, students who had demonstrated alternative conceptions on the survey were already questioning their ideas based on what they had learned in class. This presented an opportunity to observe how they assimilated the lecture information into their initial conceptual models of electrical circuits, current, and voltage. The concepts of interest were the subjects of the second lab, which took place during weeks three and four of the term; thus students were already immersed in learning the basic concepts that they were to describe in the interview. The concepts were reiterated and applied in later lab problems.

During the interview, each subject was shown the completed survey form and asked to reproduce each of circuits using a circuit board, prepared by the course instructor that included batteries in holders, bulbs in holders, terminals, resistors, and wires with

alligator clips, components found in the problems in the initial conceptual survey. The arrangement of components reflected the problems on the survey.

Figures 6 and 7 show a photo of the board and a diagram of the components on the board.

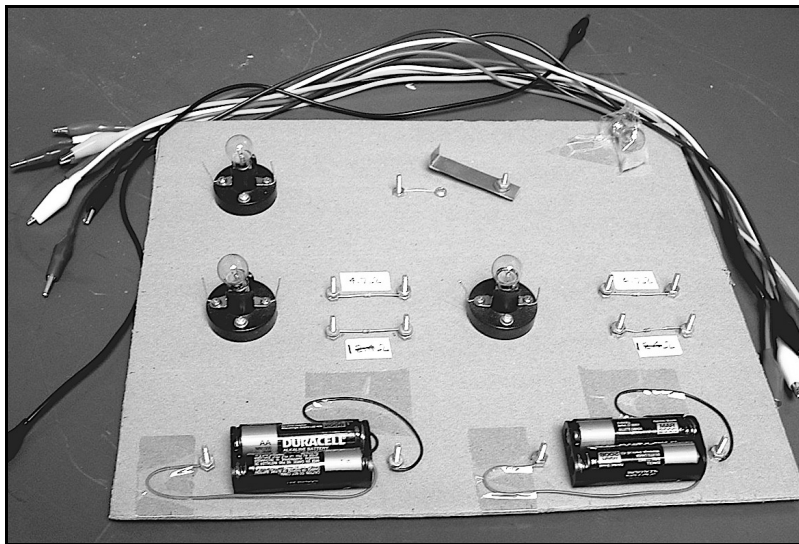

Figure 6: Circuit board used in the interviews, consisting of three bulbs in holders, four resistors (two 1 ohm resistors and two 4.7 ohm resistors), a brass switch, and two battery packs.

Before wiring the circuits, the subjects were shown their answers on the survey form and asked whether they still felt that their predictions were true, and what would happen in the circuit to cause the predicted results. While some of the subjects did not change their predictions, others did realize that their initial predictions were based on a misconception, and were able to state what they had been thinking at the time they had taken the survey as well as how their thinking had changed based on their experiences in class and lab.

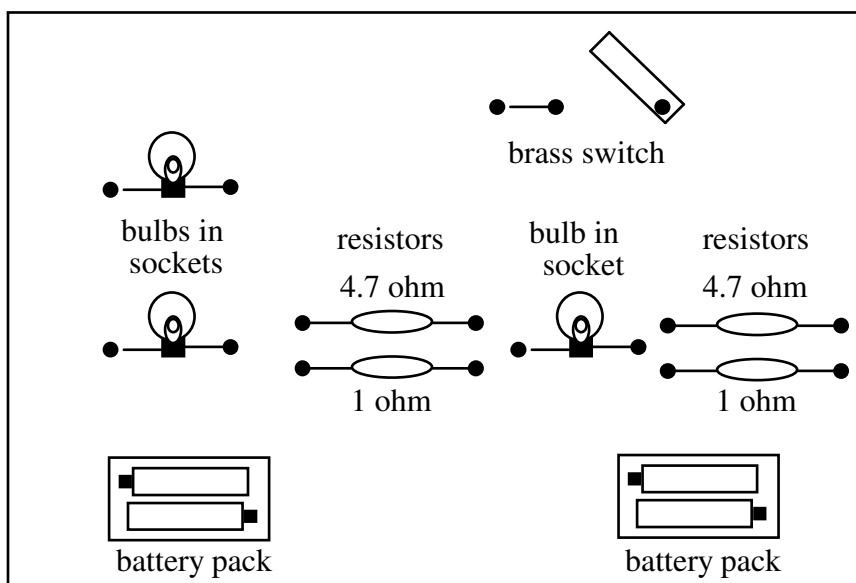

Figure 7: Diagram of the arrangement of elements on the circuit board used in the interviews.

Subjects were then asked to use the wires to create each circuit, observe the results, and explain what they saw. While in some cases students saw the results that they had predicted and reiterated their ideas about underlying processes that produced the results, in cases of discrepant results, students were forced to struggle with the conflict between the observed results and their prior predictions. Students were also asked to explain what they thought voltage, current, and resistance were.

The interviews were conducted as a dialogue between researcher and subject, with the researcher trying to follow up on the subjects' statements. The subjects were told that the researcher was interested in understanding what they thought and how they pictured electrical circuits working, rather than whether or not they knew the "right" answer.

Subjects were allowed time to explain what they pictured in their minds as they observed the behavior of the circuits they constructed. Naturally, students tried to apply what they had learned as they strove to give a correct and scientific answer. Reassurance that the researcher was interested in their mental constructions helped elicit more complete answers than, for example, “it works that way because of Ohm’s law.”

Allowing the interviewee to do most of the talking, while the interviewer listens attentively to identify further questions that can clarify views, is a technique used to reduce interviewee nervousness (Ebenezer & Fraser, 2001). Questions beginning with “How do you explain...” will help elicit student ideas, whereas questions such as “What is electricity?” tend to produce textbook definitions which they student may not fully understand. Asking students to explain their ideas also revealed their reasoning processes, as they attempted assembled their knowledge into coherent explanations, often creating if-then propositions and hypotheses on the order of: “If current is flowing this direction, then what we should see is...”

Phase III: Observing dynamics of change

The greatest challenge of this study was to illuminate and describe the dynamics of student conceptual change relative to tasks and new knowledge as students proceed through the assigned labs. This required multiple sources of data. The initial interviews revealed the beginnings of conceptual change for several of the subjects interviewed, as most of them had demonstrated alternative conceptions on the survey, but were no longer satisfied with their earlier ideas when they were interviewed and confronted with the

circuit board. Further data came from laboratory observations, copies of completed lab exercises, and the final interview.

In addition, all class lectures were observed, and the researcher took notes on the topics that were covered. The researcher also collected copies of the online class notes. From these were extracted the target concepts for the term, as well as the language and reasoning that was modeled for students.

Laboratory observations: Because of equipment availability and scheduling difficulties, lab observations on some students began before the initial interviews. Students were observed a minimum of three times in lab during the course of the term, beginning in the third week, with the goal of observing each case study student every other week during the labs of interest. At that point, students were completing the assembly of the base for their TekBots robots. In the fourth week, students began work on labs where they worked with the theoretical aspects of electricity in a series of practical exercises (see Table 1 for a list of topics). For each observation, a video camera was set up to film each student at work on the projects. Some students were comfortable talking during lab to explain what they were doing and why. Those students who preferred to work in silence were interviewed briefly afterwards in order to uncover the concepts that they had been applying to their lab tasks. In both cases, students were prompted with questions such as,

“Explain to me what you just did.”

“Pretend I’m a ten-year-old. How would you explain how this works?”

“I see you tried____. What led you to try that?”

At the end of the term, subjects brought their graded lab packets to the final interview. The researcher made copies for later analysis. Segments of video from the labs containing critical periods of discussion, reasoning, and activity were transcribed for analysis.

Final survey and exit interview

On the last day of class, all students in ECE 112 filled out the survey a second time. Results of the surveys for the entire class were reported to the instructor. Surveys for the seven case study subjects were set aside for analysis.

All seven subjects were interviewed during finals week. Exit interviews were conducted using the same format as the initial interviews. Students were presented with their completed final survey forms and asked to reproduce the circuits on the circuit board. Students were asked to explain their reasoning for their initial answers, and to explain the behavior of the completed circuits. Interviews were videotaped and transcribed for analysis.

Table 4 outlines the sources of data that relate to each of the research questions.

Table 4: *Relationship between emergent themes and data sources.*

Questions	Initial Survey	Initial interview	Lecture observations / notes	Lab observations	Student lab papers	Final Survey	Final Interview
1. Categories of common knowledge	X	X	X			X	X
2. Student reasoning		X		X	X	X	X
3. Change in meaningful learning				X	X	X	X

Qualitative analysis of data

Data analysis consisted of two phases: identification and description of commonly constructed phenomenographic categories of knowledge around electrical concepts, and identification and description of reasoning strategies employed by students as they applied their knowledge to the problems in the lab.

Constructed categories of knowledge

Transcriptions from the initial and exit interviews and the corresponding survey forms for each subject were analyzed to establish categories of knowledge that describe the conceptions about electrical circuits that students held near the start of the term and at the end. Using the phenomenographic methodology outlined in Ebenezer & Fraser

(2001), and beginning from a position of *epochè* to the fullest extent possible, student statements were taken at their value, rather than approaching the analysis with preconceived ideas of “scientific” and “alternative” viewpoints, though afterwards a theoretical validity of any one viewpoint could be established by determining how close any given statement was to an accepted scientific viewpoint. In addition, the search for student concepts proceeded from the phenomenographic viewpoint that a phenomenon is conceptualized in a limited number of qualitative ways that form mutually exclusive categories, a viewpoint confirmed by multiple phenomenographic studies (Marton & Booth, 1997; Ebenezer & Fraser, 2001).

Transcribed data from the subjects were collected into two electronic files, one from the initial interviews, and one from the exit interviews. Student written responses from the surveys were also included. The files were coded using TAMS Analyzer 3.3 qualitative data analysis software (Weinstein, 2005). The analysis for student concepts required multiple passes through the data. In the first pass, student statements related to the target concepts of energy, electricity, current, voltage, and resistance were coded using codes that summarized student statements about each of the concepts. Codes were then categorized by topic and similar codes collapsed into descriptive categories. Student-constructed models of simple circuits were extracted at this time. The categorized codes and set of models were used in a second pass through the data. Finally the codes were collapsed into limited and mutually exclusive categories of description around electrical concepts and organized into a hierarchy of concepts that were demonstrated as students progressed through the course, moving toward a target concept that was, by class

standards demonstrated in the lecture and accompanying notes, an acceptably scientific viewpoint. After the categories had been established, previous studies in student concepts of electrical phenomena were drawn upon to compare the boundaries around the phenomenographic categories, most notably Shipstone (1984; 1985), Osborne & Freyburg (1985), and Osborne (1981). While a member check at this point would have been ideal, in reality getting feedback from the study participants after the study was completed proved difficult. Comparison with other studies provided some degree of triangulation. In fact, the categories that were drawn in this study did not differ significantly from those in other studies.

A matrix was then developed, displaying the categories around each phenomenographic category into which each student's initial and final concepts fell. The matrix documented the change in conceptual understanding of each student from the beginning to the end of the term. After these terminal points were established, data from the interviews, lab observations, and lab packets were analyzed for reasoning that related to student-held concepts across the term.

Analysis of use of knowledge during reasoning: concept mapping

After categorizing student concepts, data matrices of subjects and their general categories of knowledge were used in conjunction with lists of statements extracted from interviews to construct overall concept maps, documenting the relationships that subjects expressed between the concepts at the start of the term and at the end. The concept map from the initial interview represented the knowledge that each subject carried into the

first labs. Naturally, this body of knowledge would change during the term as students attended lecture, did their homework, and carried out the lab. To determine what part of this initial knowledge was meaningful — that is, what part was spontaneously applied to solving lab problems — it was necessary to construct separate concept maps for each lab observation for each subject.

The challenge was to produce concept maps that were as fully expressive of subject concepts as possible in as concise a manner as possible. Some subjects were more talkative than others, and more willing to review their own mental processes as they worked. Even so, all of the lab observations included periods of silence and periods of trivial talk as the students worked, and there were many times when asking students to explain what they were doing would have been intrusive. While it was possible at times to relate the actions and choices that subjects made to conceptual knowledge they had expressed earlier, the majority of data used in constructing the concept maps came from the subjects' verbal communication between themselves and the researcher, other students, and the teaching assistants. This must necessarily reflect what was uppermost in their minds as they were working, and may not fully reflect all of the concepts that they were applying to the given tasks.

Furthermore it was incumbent on the researcher to allow the subjects' voices predominate and to interpret as little as possible. Nevertheless, in order to summarize and categorize subject statements and to describe connections between concepts that subjects employed, it was necessary to do some interpreting of subject meaning. Again, a member check after the concept maps had been constructed would have been ideal. However,

some triangulation was obtained by reviewing the videotaped observations after the maps had been constructed in order to test whether the statements and links were consistent with subject statements. Copies of the subjects' completed lab workbooks were also used as a source of data and to compare with the proposed maps. Where there were discrepancies between the researcher's initial map and the videotapes or the reports, the discrepant statements were reviewed and revised to better reflect the subjects' own words.

Analysis of transcripts from lab observations were used to construct a set of concept maps for each subject. Of particular interest was a description of what knowledge subjects were applying spontaneously to the lab problems (meaningful learning) and what knowledge was only applied after coaching from the teaching assistants drew it out (inert learning). The maps themselves were drawn to express the meaningful knowledge that each subject demonstrated during the observations. Each lab observation represented a new set of problems that students had to solve; thus it was possible to observe whether there were changes in the body of meaningful knowledge over the course of the term.

The following scenario with an imaginary subject illustrates the process. To create statement lists, direct utterances that students made about the target concepts of voltage, resistance, and current were taken verbatim or simplified into single statements. A series of utterances from the initial interview might read:

Interviewer: Here are the two bulbs in series, then. Before you connect the wire with the battery, tell me what you think is going to happen.

Subject: Well, these two bulbs are in series. So *the current, the electricity*, comes out of the battery, goes to the first bulb, then the second, and back to the battery. That means that *one will get the electricity before the other*. So it will *use up the power*. And there will be *less for the second bulb*. So the first bulb should be brighter and the second bulb should be dimmer. *Because the first bulb will get more than the second*.

The statements indicated in italics reveal this imaginary subject's understanding about current and the behavior of the circuit. These statements could be summarized for the concept map as:

- Current is electricity.
- Current is power.
- Current is used up by circuit elements.
- Battery is the source of current

In summarizing the statements, some degree of interpretation is necessary. For example, this subject stated indirectly that current and electricity are the same or similar, in stating, "...the current, the electricity..." Later the subject states that one bulb will

“use up the power.” Here, the subject is using the word “power” in the same way that “current” and “electricity” were used. Therefore it seems safe to interpret this as meaning that the student uses “power” as a term equivalent to “current.”

The student also describes how the first bulb gets more “power” than the second, and thus should be brighter than the second. This concept may be interpreted as, “The order of circuit elements affects their behavior,” and held as a tentative interpretation until other statements supporting this summarization could be identified. If no other statements like this appeared in other sources, the summary would be discarded and a different interpretation sought.

In lab, subjects were less likely to make direct statements about the target concepts, but often revealed their understanding of the concepts by their approach to problems or the reasoning expressed in conversations with lab partners or teaching assistants. Again, using an imaginary student as an example, a conversation between the subject and a partner might be as follows:

Student: So this is where we’re supposed to – supposed to measure current.

Right. Current through the resistor. And voltage. *Current through and voltage across*, right?

Partner: Right. Let’s use my meter to measure voltage and yours for current.

Student: Okay. Wait – which side should I measure on?

Partner: What?

Student: Which side should I measure current on? Current going into the resistor or coming out?

Partner: I don't know. Does it matter?

Student: Wouldn't it be less on this side than on this?

Here the student makes a statement that could be used directly in a concept map: "Current through and voltage across, right?" indicating that current is measured through a resistor and voltage is measured across, a concept that was taught and emphasized in the lecture.

Other statements are less direct. The imaginary student is concerned about on which side of the resistor one should wire the meter into the circuit. The student is taking order of components into account as important, and is implying that current will be used up by the resistor. This set of utterances supports the use of "the order of circuit elements affects their behavior" as a statement to include in a concept map, as well as "current is used up by circuit elements." Furthermore, this scenario would demonstrate that the student's conceptual understanding of circuits has consequences when working on a lab task. In this case, the student is convinced that current will be different when measured on one side of the resistor, and this affects how the student approaches the task. Implied in this is an *if-then* proposition that demonstrates student reasoning: "If I measure current on this side of the resistor, and the resistor uses up some of the current, then what I measure on the other side of the resistor should be different."

The concept maps were created using the lists of statements. Target concepts identified at the beginning of the study (current, voltage, resistance, circuit) were used as nodes in the map, and were indicated with the concept in boxes. Concepts introduced by students were also used as nodes. Two concepts, bulb and battery, were also placed in boxes because these were used by all students in both the initial and exit interviews, and were thus important emergent themes. Other student-introduced concepts were also used but were not placed in boxes if they were not used consistently across all maps. Statements linking concepts were used as linking arrows. The resulting maps showed the body of knowledge that the subjects revealed in the initial and exit interviews, and showed the body of knowledge applied to the problems in each lab, as well as the changes in subjects' knowledge about electricity.

After the maps were constructed, the trustworthiness of the maps was tested by again comparing the map with the original interview transcripts and observation videotapes to determine if they accurately reflected the knowledge expressed by each subject in each situation. Instances of discrepant data were reviewed to determine if the map should be altered, or if the discrepancies were thoughts of the moment and not reflective of the subjects' conceptual understanding. The final concept maps were then compared as a visual representation of subject-held concepts and relationships between concepts during the interviews and as subjects worked on tasks in the lab.

In addition, the lists of statements were collected into a single table for each subject. This provided a means of observing the changing body of meaningful knowledge expressed by each subject across the interviews and observations. In the table, statements

were identified as relating to prior contacts (interview or observation) or new information (from lecture or other sources), thus tracking the changing body of meaningful knowledge and the incorporation of new knowledge into that body of knowledge.

Analysis of student reasoning

Each subject's preferred mode of reasoning within each interview or observation was determined using Driver's (1996) typology of the Nature of Explanation. The statement lists generated for the concept maps and the connecting links in the maps themselves were analyzed to determine a probable preferred mode of explanation for each subject: phenomenon-based, relation-based, or model-based. The videotapes or transcripts were reviewed to search for statements reflecting these categories. While all students used all three typologies, the object was to determine if there was one that each student used preferentially in any particular observation.

Phenomenon-based reasoning was demonstrated by a tendency to explain phenomena using further examples of the same phenomenon. A student who preferentially used phenomenon-based reasoning would use statements such as, "The bulb dims because there are more bulbs in the circuit. It's like in this other circuit with the switch. When the switch isn't pressed, you have two bulbs in the circuit. So they're dimmer." Such a student recognizes similar examples of the same phenomenon, but tends not to use underlying causes in an explanation. For example, the student may say, "Two bulbs in a series are like putting a resistor and a bulb in series. The bulb is a resistor, so you just have two resistors in series." Without explaining what resistance is, and why it would

cause the bulb to dim, the student is focusing on the objects in the circuit and their appearance rather than the cause of their appearance.

Relation-based reasoning was seen in students who sought underlying causes that explained and unified multiple phenomena, and who clearly showed a sense that they were trying to answer a “why” question. For example, a student would be using relation-based reasoning in explaining the dimming of bulbs in a series as follows: “If you add a resistor to the circuit, it increases the resistance. Resistance slows down current. And current is what makes the bulb light, so the less current, the dimmer the bulb. Bulbs are resistors, too, so adding more bulbs slows the current down, making less current, making all the bulbs in the circuit dimmer.” The difference here is that the student’s explanation focuses on *what resistance is* instead of *what resistors do*.

Model-based reasoning was characterized by students who referred to a mental model, a model presented in the lecture, or a mathematical model as a unifying model to explain multiple phenomena and to make predictions and conjectural explanations. Students using model-based reasoning will also compare, contrast, and consider various alternative models and explanations to a given phenomenon. The model that they employ might or might not be scientifically accurate, but it forms the student’s approach to a given problem. For example, a student with an alternative model of simple series circuits who also employs model-based thinking might approach an exercise involving a series of resistors thus:

Student: Let’s think about this first. So if the current runs from the battery, through the resistors, and back to the battery, and each of these resistors is using

up current, then there should be more current when we measure current at R1 than at R5. And because the current is decreasing, the voltage will also decrease, so we should get a graph like this [sketching linear graph].

When confronted by data that do not fit the student's explanation, the student who employs model-based reasoning, if the data are viewed as valid, would question the old model and attempt to seek a new model. The difference between this and relation-based reasoning is that the relation-based reasoning student is asking, "Why did the circuit behave as it did in this case?" while the model-based reasoning student is asking, "How do circuits in general work? How does the activity in this circuit predict the activity in another circuit?"

Chapter 4: Results

Introduction

In order to present the multiple aspects of this study, this section is divided into four sections. In the first section, *Constructed Categories of Knowledge*, a case will be made for the categories of knowledge around basic electrical concepts that were extracted from conceptual interviews with each subject. A description of each category will be presented with examples of student statements that fall into each category. The second section, *Models of circuits*, discusses overall models demonstrated by the subjects when making and testing predictions about circuits. Though the term “mental model” is not entirely consistent with a phenomenographic approach, it was useful for this discussion, since the subjects did show a decided preference for particular coherent models when first making predictions. If the model was contradicted by evidence, they tended to construct a model of the moment, assimilating prior knowledge and topics learned in class. The third section, *Student use of knowledge during reasoning*, will discuss concept maps developed from student statements and the changes shown by each student across the term. The fourth section, *Quality of student reasoning*, examines how students applied knowledge and created explanations as they worked on the lab tasks.

Constructed Categories of Knowledge

In describing students' constructed categories of knowledge, transcribed interviews were examined and coded for instances of student statements about electricity, current, voltage, and resistance. In addition, students demonstrated concepts about batteries and light bulbs that proved useful for describing their working models about how circuits function. The codes were then grouped into overall categories of knowledge and the data re-coded with the new set of codes. A matrix of student concepts was created showing which concepts students held at the beginning and the end of the term. Finally, a hierarchical set of phenomenographic and mutually exclusive categories were developed to describe progress in student concept development over the course of the term.

Students overall had a tendency to conflate the concepts of current and electricity as in this statement:

That's what I'm learning in class and I'm not so positive, but I know that my first theory is that I always thought — *power or electricity or whatever* went out the positive, but it actually is electrons flowing to the negative? (JF, initial interview, italics added for emphasis)

Indeed, the class notes emphasized concepts of electrical current such that the two concepts, current and electricity, were not explicitly separated, nor did it appear useful to the goals of the class to do so. When students discussed “electricity” it was always in the

context of moving current. Therefore a separate set of categories about electricity apart from current were not developed.

Primary concept: nature and function of batteries

While the nature of a battery was not a topic of emphasis in the lectures, the robot platforms had a rechargeable battery pack that the students had to assemble and that had to be wired into the robot in a way that it could either dissipate power (when being charged) or generate power (to supply current to the robot). Thus students used batteries throughout the term and had to form an understanding how the batteries worked, and the concept of “battery” emerged as an important construct for these students during the lecture and the labs. Their ideas of what batteries were and how they functioned had consequences in the lab as their ideas shaped their decisions about lab tasks.

One set of class notes on power dissipation included rechargeable batteries as an example of a component that can both generate and dissipate power, and included a water hose analogy to explain generation and dissipation. As students learned the concept of voltage, the battery was described in lecture and in class notes in terms of a source of potential chemical energy and as a voltage source. The printed class notes on voltage included this statement:

A battery is an energy source that provides an electrical difference of potential that is capable of forcing electrons through an electrical circuit.

We can measure the potential between its two terminals with a voltmeter.

Thus the target concept for “battery” in this class included *energy source*, *potential difference*, and *cause of current*.

Student concepts around batteries included these target concepts, but also included some alternative conceptions. Three categories of knowledge were defined:

- Battery is a repository of current
- Battery is a voltage source
- Battery supplies voltage which causes current

Battery is a repository of current

In this view, subjects often conflated “energy,” “power,” “electricity,” and “current,” and described these in material or quasi-material terms. The battery was in essence a storage tank of this perceived substance or near-substance, be it “electricity,” “power,” or “energy,” and components of the circuit “used up” the material, thus draining the battery. It is probable that student experiences with weak or “dead” batteries and with rechargeable batteries either gave rise to or supported this conception, since the subjects all had experienced batteries that weakened with use, and all subjects used a set of rechargeable batteries in their TekBots.. Subjects who demonstrated this viewpoint

tended not to see current as conserved in a circuit; rather, they were more likely to believe that current was “used up” in the light bulbs.

This makes sense because it’s kind of — because the battery puts out much more electricity than, you know, that the light bulb can use up.
(YZ, initial interview)

Through the whole circuit, there’s only so much electricity going through, and it’s going to, through here it’s going to give out the same amount, I mean, there’s only so much there in the whole thing, it’s going to give out certain amount here (pointing to B) and a certain amount here (pointing to C). (AM, initial interview)

Battery is a voltage source

Subjects with this viewpoint showed awareness of the amount of voltage printed on the battery, and described the battery as supplying that voltage, though they might demonstrate alternative views of exactly what voltage was. In one way or another, the battery was understood to supply some material or phenomenon called “voltage” to the circuit. Because there are multiple views of voltage, is possible that this category should be divided into sub-categories reflecting different views of voltage, but there was insufficient data in this study to justify such a division. What separated “battery as a voltage source” to the next category, “battery supplies voltage which causes current” was

the lack of an explicit causal connection between voltage and current in student explanations.

It would have to be since they're in parallel, the voltage across each, all three of the light bulbs is equal because they all have the same batteries so they all have the same voltage source... (MJ, initial interview, problem 2)

We're going to have, like this is what? (pointing to battery) 3 volts total on the circuit here. (TA, initial interview)

Battery supplies voltage which causes current

In this viewpoint, students understand that the voltage across the battery is what drives current. Underlying this viewpoint is a fairly sophisticated model that requires students to consider multiple phenomena simultaneously, and this requires a strong understanding of the basic concepts. By the time of the initial interviews, all subjects had learned this concept in class and had the explanation available in their class notes. Only one student, KR, demonstrated this model explicitly during the initial interview, and though his language around the concept lacked sophistication, he drew on class examples as he explained his understanding:

KR: All right, um, stored potential chemical energy is in the batteries, and um, like the description that I think was explained in class was like pool balls are filling the pipes up to the light bulb, so it's kind of like a chain in effect, you hit one and it sends the um current through the circuit, and um, that current passing through the filament lights up and the filament releases heat and light. (KR, initial interview)

Table 5 indicates the categories of knowledge around batteries held by each of the seven subjects during the initial and final interviews.

Table 5: Distribution of student concepts across the conceptual categories of knowledge around the nature and function of batteries. Full explanation of the categories is in the text. "1" indicates the initial interview, "2" the final interview.

Primary concept: nature and function of batteries	A M 1	A M 2	Y Z 1	Y Z 2	M J1	M J2	K R 1	K R2	J F 1	JF 2	A K 1	A K 2	T A 1	T A 2
Battery is a repository	X		X						X	X	X			
Battery is a voltage source		X		X	X									X
Battery supplies voltage which causes current							X	X	X				X	X

Primary concept: Nature and function of light bulbs

While all subjects generally understood that something from the battery caused the light bulb to light up, and that the something flowed back to the battery, their knowledge of what happened inside of the bulb varied somewhat. Neither the class notes nor the lectures explicitly described how a light bulb functions; this was assumed to be common prior knowledge, and indeed, a large majority of all students in the class held the understanding that the emission of light represented an energy conversion. Two categories of knowledge were defined:

- Light is the result of a chemical reaction between electricity and chemicals in the bulb.
- Light is the result of a conversion of electrical energy to light (and heat) energy. Bulb is a resistor.

Light is the result of a chemical reaction between electricity and chemicals in the bulb.

This view was unexpected, as it had not been encountered in the literature. It accompanied an understanding of electricity as material or quasi-material. The electrical substance was believed to mix with chemicals in the bulb or cause a chemical reaction in the bulb that resulted in the emission of light. Since one subject, YZ, was not a native English speaker, the researcher took pains to make certain that this was the understanding that he was describing and that his description was not arising from a difficulty with the language.

I: Okay. And then what is it that actually makes the bulb light?

YZ: You know, I don't know that. [laughs] Um, probably some material that um, reacts violently to the light? To the electricity? I was thinking I heard about it before but I never really, I guess, a logical explanation for it, like what the material is made of, and why it reacts to — why it lights up when current goes through it. (YZ, initial interview)

I: Okay, so inside the bulb itself, what's happening?

AM: The power's mixing with whatever's inside, um, the, (turns to interviewer) the chemical that's inside it. (AM, initial interview)

Light is the result of a conversion of electrical energy to light (and heat) energy.

Subjects who held this view, in which light that is emitted from a bulb results from an energy conversion, linked this to the fact that the bulb is a resistor. These subjects described light, heat, and electricity as forms of energy, and stated that different forms of energy could be converted into other forms. They linked the idea of the bulb as a resistor to its emission of heat and light.

MJ: Well, the current is flowing from the batteries to the light bulb, and it goes through the filament, you know, like a resistor, they say it puts off more heat resistance, or heat energy than light energy, but there's light also, and then it goes back to the ground. (MJ, initial interview)

Primary concept: the nature of current

In the class notes and during lecture, students were informed explicitly that current consists of electrons in motion through a material. The phrase “current consists of moving electrons” was printed in bold face at the top of the class notes for the first day of class. The notes contained this description:

Conductors such as copper are filled with movable charge not unlike a cloud of electrons. A net flow of these charges within the conductor constitutes electrical current flow. An external influence is required to cause the electrons to move through the conductor. This force is usually an applied electric field. When the electric field pushes against the electron cloud, the entire cloud, acting as one, moves. In this way electrons are caused to flow at the opposite end of the electron cloud.

The notes also supplied an analogical model to aid understanding:

Here is another way to think about current flow. It's the “pipe and ball” analogy for conductors. A conductor is like a pipe full of electrons. If an electron is pushed into one end of the pipe, another electron must fall out at the other end. Think of electron flow through a wire as balls traveling through a pipe, not like an empty pipe that electrons “fall” through.

Thus the target concept for current was the *flow of electrical charges* or the *flow of electrons themselves*. Students learned that this directional flow of electrons moves in the opposite direction to what is conventionally labeled current flow, and were given historic reasons for this. The dual descriptions of current flowing one way and electrons flowing another caused confusion among the subjects as they sought to understand exactly what was flowing, in what direction, and what were the resulting consequences. None of the subjects appeared to reconcile the two models of current to their satisfaction over the term.

As subjects described current in the circuits that were presented, they displayed an intuitive sense of current as something that flowed or moved through the wires. All subjects indicated a definite direction to current flow on the diagrams, and moved their hands in a circular direction over the actual circuits when explaining the path that they thought current took. Two categories of knowledge around the nature of current were defined from their responses:

- Current is material or quasi-material; thus current can be “held back” or can “pool behind” resistors.
- Current is energy or power

Current is material or quasi-material

Subjects holding this viewpoint accepted the concept that current is the flow of electrons. But their mental conceptions electrons tended to be highly material in nature.

Their focus was on the perceived particulate nature of electrons; hence moving particles (electrons) was equated with moving substance. The analogies used in lecture, in which current flow is compared with water or balls moving through hoses or pipes, may have reinforced a material model of current.

The view that current is the flow of something material or quasi-material had consequences for other concepts. As already discussed, a material view was paired with a tendency to view the battery as a repository for the substance. This material was believed to be “used up” by components of the circuit, which led students to believe that bulbs in a series had differing brightnesses because the “first” in the series would “use up” the current. Furthermore, a material view affected how students viewed the action of resistors. One subject, JF, stated that while filling out the initial survey, he’d believed that resistors were like dams in a stream, and that current could pool behind them.

I’ll tell you what my thought process when I thought that. Now that I think I’ve — I think I’ve learned something. My thought process was that it’s going to be flowing this way, so if it gets resisted here [pointing to R2], more is going to have — like water flow. If you — if this is dammed up, if you dam before the light bulb it’s going to get less, if you dam after it’s going to get more water. That was my theory. (JF, initial interview, problem 5)

Current is energy

In this view, subjects tended to equate current with the idea of energy: it is something, often a vague something, that is supplied to a bulb that makes the bulb light, that flows, that is dissipated at a resistor as heat, and that is an energetic phenomenon rather than a material substance. When asked, subjects used the learned phrase that current is electron flow, but in their descriptions of circuits they tended to describe current in looser, energy-related terms and rarely referred to moving electrons or charges.

I: Now how is this wired in parallel [third problem] different from this wired in parallel [second problem]? Why do we have such different results from those two?

AK: Um — this one from this one? Well the battery's pushing across these two, and then pushing across a third one before it gets back. So because of that, this takes up half the energy of the battery, and these take a fourth just to make it through back here, whereas any one of these [in parallel circuit in prior problem] gets all the way back to ground — full amount of energy [gesturing in circle over the diagram], full amount of energy [indicating second wire on diagram], gets used right there. But whereas this one [current problem], it takes a full amount of energy that way, full amount of energy that way [gesturing over diagram], er, half of it goes this way, half of it goes this way. And so. (AK, final interview, problem 3)

Table 7 indicates the categories of knowledge around current held by each of the seven subjects during the initial and final interviews.

Table 7: *Distribution of student concepts across the conceptual categories of knowledge around current. Full explanation of the categories is in the text. “1” indicates the initial interview, “2” the final interview.*

Primary concept: current	A M 1	A M 2	Y Z 1	Y Z 2	M J1	M J2	K R 1	K R2	J F 1	JF 2	A K 1	A K 2	T A 1	T A 2
Current is material or quasi-material	X	X				X			X					
Current is energy			X	X	X		X	X		X	X	X	X	X

Primary concept: Voltage

While students had an intuitive sense of current as something that flows, water-like, through a circuit, voltage was a far more difficult concept to grasp. When asked to explain what they believed voltage to be, subjects tended to rely on learned analogical models to explain voltage and what effects voltage had on the actions of a circuit. In the initial interviews, subjects tended to focus on current and seldom mentioned voltage. In the exit interviews, subjects were more inclined to include voltage in their explanations, though several still held alternative conceptions about voltage.

The concept of voltage was introduced in the first week of class in a set of notes titled: “Voltage: electromotive force.” The notes began with this statement:

Electrical current flow is the movement of electrons through conductors. But why would the electrons want to move? Electrons move because they get “pushed” by some external force.

The notes then introduced a water analogy to explain voltage, stating that for water to move through a hose, there must be a difference between water pressure at one end of the hose and pressure at the other:

If a hose is connected between two faucets with the same pressure, no water flows. For water to flow through the hose, it is necessary to have a *difference in water pressure* (measured in psi) between the two ends. In the same way, for electrical current to flow in a wire, it is necessary to have a *difference in electrical potential* (measured in volts) between the two ends of the wire.

Thus the target concept of voltage included both the nature of voltage as *electromotive force*, and its causative effects as *pressure or “push.”* The idea of voltage as pressure or “push” was an analogical model that subjects tended to pick up on over the term and use in their explanations. Though they used terms such as “electromotive force”

or “potential energy” to define voltage, the “push” analogy was meaningful to them as they attempted to use voltage in their explanations of circuit behavior.

Three categories of knowledge were described around the concept of voltage:

- No concept
- Voltage is current or is like current; voltage flows or moves
- Voltage is a measure of the strength, size, or force of current.
- Voltage is pressure or push, which moves electrons.
- Voltage is potential energy.

No concept of voltage

In the initial interviews, two of the subjects did not have any clearly developed concept of voltage. When asked about voltage, their explanations were vague and uncertain, and both stated that they did not really know what voltage was, suggesting that their explanations were models of the moment. Both students relied on models of current flow to explain the behavior of circuits, without being able to explain what causes current to flow:

JF: Um, because they're all using the same — the power source is the same. You're going to have the same amount of current going through them, and they're going to have the same — [stops and looks puzzled] — um volts going through them. I think. [looks doubtful]

I: Volts do what? Where will the voltage be in here?

JF: [shakes his head] I'm really not doing all that well in the class, I'm following very slowly and dragging, and every time I think about anything I always look it up. (JF, initial interview, problem 3)

The students did, however, attempt to apply memorized statements from class to the problems presented in the interview, as they struggled to understand the new concept.

YZ: Well — in series, let's see — (thinks) what I remember he said is in series they're the same current but different voltages. And in parallel they're the same voltage but different current. (YZ, initial interview)

Voltage is current or is like current

As students with absent or vague understanding of voltage worked to understand the nature of voltage, some attempted to equate voltage with current. To talk about how voltage “moves” or “flows” is to conflate it with current, which the course instructor pointed out during a lecture was a common misunderstanding frequently seen in newspaper articles describing electrical accidents. While subjects did not always say explicitly that voltage was current, they used definitions and explanations that were similar to those that they used for current.

I: For instance, you measure voltage in lab.

AM: Right.

I: So what do you picture yourself measuring?

AM: (long pause) The — number of electrons at a give moment?

(Looks back at interviewer)

I: Okay. So when it says it's such-and-such volts, or when you measure so many volts across a resistor, we're measuring electrons with them?

AM: Uh, no. (thinks) Hm... The current would be the flow of electrons, and R, resistance is how many electrons are being held back, er, not how many, it's just, just a number. I mean, 4.7 ohms, it's not going to hold back 4.7 electrons. So yeah, I guess it makes sense that voltage would be the number of electrons. (AM, initial interview)

Voltage is a measure of strength, size, or force of current

Through instruction and direct experience in taking separate measures for voltage and current, students developed an understanding that voltage is not current. In trying to explain exactly what voltage is, some students, took voltage to be a measure of some quality of current, related to strength, size, or force of the current. This view may have been influenced by the water pipe analogy, leading students to believe voltage was a measure of the force of the current, just as a pressure gauge measures the pressure in a pipe.

I: Well, for example, the battery is labeled so many volts. What does that mean?

AM: (thinks) Voltage.

I: Or when you were measuring voltage in lab. What was it that you felt you were measuring? ...

AM: I'm going to say it's the change of, um, like electrons flowing. Not flowing. Just the like either the drop or the increase between one point and the other. (AM, final interview)

I: Okay, so how do you define voltage in that case? What is voltage?

Y: It's the um, amount of electricity flow, difference in, the electron flow difference on both sides of the node. (YZ, final interview)

Voltage is pressure or "push"

In trying to explain how circuits functioned, several subjects found the water pressure analogy useful. Though subjects were not always able to distinguish analogy from physical reality, the analogy was a fruitful explanatory and predictive model as students predicted and tested the behavior of circuits and as they worked on their tasks in lab. One subject, AK, used the analogy of "push" in the initial interview and all the way through the course. He was one of the few students who preferred to explain circuits using voltage (or in his terminology, "push") rather than current as a primary factor. While AK

understood that voltage involved potential energy and potential differences, his preferred mode of explanation was to talk about “push”:

AK: Yeah, the bulbs are the same amount of resistance, and so when the voltage is pushing across only one bulb it can make it really bright and, um, a great big voltage drop across there. So most, all the push is getting used up, whereas here it has to push across two different ones, um, simultaneously so it pushes some here and the rest here. Uses up the rest of the energy. So — and since they’re all the same resistance, this one has the most energy across it, and those two have half as much energy across them.

I: Now, if we’re measuring voltage in there somewhere, what is it that we’d be measuring? What is voltage?

AK: Um, the amount of, um, potential that the, that there is, that the uh, the amount of holding, okay, um, the amount of push that it can, um, how much it can push current. Um, if it’s — more than a lot of protons to one side, er, a lot of electrons on one side and lack thereof on the other, and so it’s, the voltage would be how much it can push anything at a given point from there to ground. So, or from one point to the other, how much, um, how much the batteries or voltage source can push, um, electrons from one point to another. Not how much it actually is pushing but how much it can. (AM, final interview, problem 2)

Voltage is potential energy

Care had to be taken in constructing this category to distinguish between subjects who used the phrase “potential energy” in their explanations yet understood voltage as something else, and those who used “potential energy” in the manner used in lecture. Also in this category were explanations that did not necessarily use the phrase “potential energy,” but described the concept in ways that showed an understanding similar to what was taught in the lecture.

Using “voltage is potential energy” as their favored conceptual understanding of voltage was linked to a switch from using a literal model of current flowing through pipes with voltage as the pressure, to thinking about relationships between phenomena within the system as a whole. For example, early in the term, MJ explained voltage this way:

I: So when you're measuring voltage, what is it that you're measuring?...

MJ: Well, it's not measuring the current, it's measuring the pressure of the current. The um, way he explained it in class was relating it to water, where the quantity of the water is the current and then the pressure of the water is the voltage, you know, the pressure of the current. (MJ, first observation)

At the end of the term, MJ defined voltage as electrical potential:

I: Okay, so what is voltage?

MJ: It's the change in potential from here to here (pointing to resistor on diagram) or from here to here or wherever you're measuring it from.

Change in electric potential. (MJ, final interview)

And her explanations of how circuits work took on a more algebraic tone than they had earlier in the term:

MJ: They're both getting the same voltage from the battery doing it like this. And this way the voltage to each of them can only be equal to the voltage across the battery it can't be — and since the resistance of each of them is assumed to be equal, then this is, this can only get half of the voltage of the battery and this can get the other half. But this way they can each have the full voltage of the battery.

I: Okay, so then would you say A is brighter than D or as bright as or—?

MJ: I think they all look about the same. But what did I put? A is brighter than D. And that's wrong. Yeah, this would have made more sense for how I had it wired before, what I wrote. Would have made more sense for that. But like if we were trying to solve this circuit, the voltage across E would be the same as the voltage across the battery, which would be the same as the voltage across D, and then in A, the voltage

across the battery is equal to the voltage across A, so they would all have to be the same. (MJ, final interview, problem 2)

Subject TA, who also thought of voltage as potential energy, also described circuits in highly algebraic terms. TA also integrated interrelated concepts into his responses:

I: So, explain to me what's happening. Why does increasing the resistance cause voltage to rise here and to drop here? Why doesn't this just stay the same when we haven't changed that resistor?

TA: Well, because then you would change your voltage, and your voltage stays the same. You've got one — three volts. So that's not going to change. So if you increase — if you change the voltage in the one, it's going to change it the other direction. But since V equals IR , um, then you're increasing resistance, and they're directly proportional, so you're increasing the voltage drop across it also. And by increasing the voltage drop across this one, you have to decrease the voltage drop across this one to maintain the three volts. (TA, final interview, problem 7)

Table 8 indicates the categories of knowledge around voltage held by each of the seven subjects during the initial and final interviews.

Table 8: *Distribution of student concepts across the conceptual categories of knowledge around voltage. Full explanation of the categories is in the text. “1” indicates the initial interview, “2” the final interview.*

Primary concept: voltage	A M 1	A M 2	Y Z 1	Y Z 2	M J1	M J2	K R 1	K R2	J F 1	JF 2	A K 1	A K 2	T A 1	T A 2
No concept of voltage			X						X					
Voltage is current or is like current	X													
Voltage is a measure of the strength, size, or force of current		X		X				X						X
Voltage is pressure or “push”					X					X	X	X		
Voltage is potential energy							X	X						X

Primary concept: Resistance

Like voltage, resistance was a difficult concept for many students, and two of the subjects began the term with no clear model of resistance.

The class notes in the second week introduced the concept of resistance while introducing Ohm’s Law. The notes relied on a water analogy, comparing wires to fire hoses and resistors to drinking straws: forcing the water in a fire hose through a drinking straw slows the flow of water considerably. The drawback to this analogy is that it could lead to ideas that current can pool “behind” a resistor. On the molecular level, the notes explained resistance this way:

A wire is an ideal conductor with no resistance (at least for our discussion). In contrast, a *resistor* is a component that purposefully impedes or opposes the flow of electrons. As an externally applied electric field is applied to force current through a resistor, the electrons diffuse through the resistive material like a gas through a sponge. The electrons gain energy from the external field but once they start to move, they bump into an atom in the resistive material and lose some kinetic energy. How fast the electrons bump through the resistor depends on the intensity of the externally applied field. The stronger the field, the faster the electrons diffuse through the material increasing the number of electrons passing through per second. The speed at which electrons diffuse through the material is called the *drift velocity* and it is proportional to the applied voltage.

In energetic terms, a target concept for understanding resistance might be *loss of kinetic energy*. However, the phrase from the notes that students appeared to assimilate the most was, "...a *resistor* is a component that purposefully impedes or opposes the flow of electrons." This definition was used during the lecture, indicating a target concept of *impeding the flow of current*.

All subjects were familiar with the phrase "the path of least resistance," and used it on an interview problem involving two bulbs wired in series, with a switch bypassing one of

the bulbs. Subjects correctly predicted that the bypassed bulb would dim or go out when the switch was pressed because the switch had less resistance, and therefore current would preferentially take the path with least resistance. However, not all subjects predicted that the second bulb would get brighter at the same time that the bypassed bulb went out, indicating limitations to their knowledge of the effects of resistance on the circuit as a whole.

Three categories of knowledge around the nature of resistance were defined:

- Resistance is holding back current
- Resistance is a restriction of current flow
- Resistance is the dissipation of energy

Resistance is holding back current

In this model, resistance involves physically pushing back on moving electrons. A resistor is seen as providing a backward force in the system, or acting like a traffic cop in preventing electron movement. Often this was linked with a material view of current, and led to JF's initial model, quoted earlier, in which he believed that resistors were like dams in a river and that current could pool behind them; thus a bulb "behind" a resistor would get brighter if the resistor "in front" of it were increased because it would have more current, just as a lake behind a dam accumulates water. Other subjects expressed similar ideas of blocking or holding back current:

YZ: Like a water flow, if there's something blocking, it's more like you actually have a force pushing back from the resistance and create more current in the other direction [branch in a circuit] where it actually can flow through. (YZ, initial interview)

Confrontation with actual circuits helped dispel the idea of a circuit in which the effects of a resistor depended on whether it came “before” or “after” a component in a circuit, and at the same time helped students alter their conceptions about resistance, as in this exchange where subject AM reasons his way through a problem involving a bulb with resistors on either side of it:

I: Yeah. So why does it get dimmer when you put the larger resistor in? What is the resistor doing?

AM: It's holding back some of the — electricity.

I: Okay. And then when you increase the other one, what happens?

AM: Gets dimmer! Okay.

I: Why is that?...

AM: Maybe because it — I figured the current is set — (quietly)back and forth — (unhooks wires and tries the two resistors for R2 again, comparing resulting brightness of the bulb)

I: What if instead of a resistor, that was another light bulb in that circuit? Would that make the bulb dimmer?

AM: Yeah.

I: So does that help you explain it?

AM: All right. So you have the whole total over the whole thing. Obviously if I took out this resistor (R1) that would be bright, put that one in and it's dim, but this one is dim, because it has to — divide through the whole circuit — whatever power's going through it.

I: So does it make a difference what order the elements are in?

AM: I would think so, but maybe not? (thinks for a while) From this I'm thinking no. (AM, initial interview, problem 5)

Resistance is a restriction of current flow

In this view, subjects described resistance as slowing or restricting the flow of current, rather than physically forcing it back. The view corresponded to the analogical model presented in the notes and in lecture of water rushing down a hose and encountering a soda straw.

I: So what is going on in that resistor that's causing that effect?

JF: It's slowing the current down. It's resisting the current. Exactly how the resistor works I'm not certain, I know that if you put too much current through a resistor, they'll either burn up or they'll get warm. (JF, final interview, problem 5)

TA: I imagine the resistance — the internal resistance in the light bulb restricting the flow of current is what's — somehow the energy's converted there. (TA, initial interview)

Note that though TA favored the idea of resistance as restricting current, the quoted response here indicates a willingness to consider other models. TA tended to remain with this viewpoint throughout the term, but still considered the idea of energy conversion somehow involved in resistance, and in fact had no difficulty with a lab task involving the calculation of energy dissipation by resistors.

Resistance is the dissipation of energy

This view consisted of a mental image of resistance that closely resembled the *loss of kinetic energy* explanation from the class notes. In the initial interview, KR offered this description of resistance which included a kinetic component:

I: Okay. So what exactly is resistance? What is that doing?

KR: Um, making it hard to get through. Uh, it's like a car going through mud, or what else? Like a ball rolling on carpet instead of a marble floor, kinda. (KR, initial interview)

In the final interview, this kinetic concept was more developed, and expressed in terms of the dissipation of energy:

I: Yeah, you can really see it that way. Okay, so what is increasing resistance do that causes the bulb to dim?

KR: Basically puts another light bulb in the path, which dissipates the electricity. The current. Which makes this grow dimmer.

What was interesting about this response was KR's comparison of resistors and light bulbs. Other subjects had stated that light bulbs were resistors. Only KR stated that resistors were like light bulbs, acknowledging that the comparison goes both ways.

YZ also included dissipation in his concept of how a resistor works, though his overall concept was that of resistance as restriction of current:

Y: It's the um, amount of electricity flow, difference in, the electron flow difference on both sides of the node. Off a resistor or any part that's a dissipater. (YZ, final interview)

In spite of carrying out a lab activity in which students touched resistors in a circuit to feel the actual dissipation of heat, none of the other subjects appeared to use dissipation in constructing their concept of resistors, apart from explanations of how light bulbs work.

Table 9 indicates the categories of knowledge around resistance held by each of the seven subjects during the initial and final interviews.

Table 9: *Distribution of student concepts across the conceptual categories of knowledge around resistance. Full explanation of the categories is in the text. “1” indicates the initial interview, “2” the final interview.*

Primary concept: resistance	A M 1	A M 2	Y Z 1	Y Z 2	M J1	M J2	K R 1	K R2	J F 1	JF 2	A K 1	A K 2	T A 1	T A 2
Resistance is holding back current	X	X	X				X		X					
Resistance is the restriction of current				X	X	X				X	X	X	X	X
Resistance is the dissipation of energy								X						

Models of Circuits

As subjects developed predictions and explanations about the behavior of circuits, it was evident that they had some prior ideas about the overall way in which the components should operate and react to changes. These overall ideas are described in the literature as models of circuits. While it was evident that the subjects in this study were at times assembling an overall explanation from bits and pieces of knowledge, particularly when their predictions turned out to be incorrect, they also demonstrated some preferential preconceptions about the general way in which circuits function that can most easily be described as mental models. Because the first interviews took place during the early weeks of the term, some subjects were already becoming dissatisfied with some

of their earlier thinking; thus some were in a transitional state between a prior model and ones learned in class — or rather, their perception of the models learned in class.

Simple, series, and parallel circuits

From the data on the surveys and the interviews, four types of student models around simple circuits were described:

1. Linear: this model corresponds to the unipolar model described by Shipstone (1985). The term “linear” is used here as it describes the perceived direction of current: a straight path from source to element. In this model, students draw a single wire connecting one terminal of a battery to a bulb.
2. Circular, sequential: subjects who preferred this model described current as moving in a circular pattern, from battery to circuit elements and back to battery again. Along the way, the circuit elements such as light bulbs may “use up” the current, leaving less available to elements that were “downstream” of the first in the circuit, a model that corresponds to the attenuation model described by Shipstone (1985). Even where the idea of current being “used up” in the circuit was not explicit, students still clearly expected that the order of elements in the circuit mattered. For example in problem 5 of the survey, where subjects considered the effects of increasing the size of a resistor on either side of a bulb, subjects with a sequential model would predict different results depending on which resistor was increased: a

larger resistor “upstream” of the bulb would dim the bulb, whereas a larger resistor “downstream” would have no effect.

3. Transitional: subjects who were labeled “transitional” used both a circular sequential model and a non-sequential interrelational model in their explanations. Often these students used non-sequential explanations when discussing two bulbs in series and in parallel, especially after they had gained experience with circuits in lab. However, when discussing more complex circuits, their responses often contained elements of a model in which current is consumed by elements in sequence, or the expectation that the order of elements in a circuit would have an effect on the outcome. It is possible that students who were in transition had learned that series and parallel circuits perform in a particular way, but did not yet understand why, and thus had difficulty applying their knowledge to more complex circuits.
4. Non-sequential interrelational: subjects considered the circuit as a whole when predicting the effects of change in one element on another, and did not view the order of elements as important. They often talked about the circuit in mathematical terms, as in describing the total resistance of the circuit, or noting that the voltage across the battery equaled the voltage across the circuit. For example, in problem 5 of the survey, where subjects were asked to consider the results of increasing the resistance on either side of a bulb, subjects holding a non-sequential model would predict that changing to a larger resistor would increase resistance in the entire circuit, thereby dimming

the bulb regardless of which resistor was increased. Their responses most closely resembled the target concepts taught in the course.

Linear model

Only one subject, MJ, demonstrated the linear model of a circuit, and her use of this model did not last long. On the initial survey, when asked to draw a circuit that included a battery, a bulb, and wire, she drew a single wire connecting the battery and bulb. But as MJ related later in her interview:

I: Okay, now, so comparing this with your original diagram, do you think that would make the light bulb light up?

MJ: No, because I didn't, I just — stuck it on the end of the battery, no that wouldn't really work. *Because, I played with a light bulb and a battery and stuck them together and nothing happened.* (laughs) I didn't really understand how to connect the wire and stuff in the drawing, so I figured well you have to connect the battery and the light bulb and that was the only way I could figure out how to do it (laughs). But I... yeah. This makes more sense (pointing to board) because there's two terminals, and at the time I was drawing that I didn't realize that the batteries had the two terminals. (MJ, initial interview, problem 1, italics added for emphasis)

Thus it is probable that her model was a model of the moment, constructed from the elements that were available at the time. Not only was MJ dissatisfied with her initial model, but she also spontaneously tested her model after the survey and discovered for herself that it did not work. This initiative served her well as MJ, who entered the class with low prior knowledge, worked to master the concepts taught in class.

Circular sequential model

Three subjects, AM, YZ, and KR, used the circular sequential model on their initial surveys though they were already growing dissatisfied with the model in their initial interviews.

AM, in fact, was already showing some dissatisfaction with the model at the initial interview:

I: ...I'll have you wire this one to be A and these two to be B and C, the way they're wired in series, and let's see what you predicted. You predicted that B would be brighter than C, and that A would be brighter than B. Still want to go for those predictions?

AM: (long pause) Um— (long pause, looking at survey) I think B and C, probably, might be equal.

I: And why do you say that?

AM: (thinks some more) No, I still think it's B's brighter than C. Because it's going to go through here, and whatever's left over is going

to light this one. Or was it— (thinks some more) unless it evenly distributes.

I: Okay. Well, let's put it together and try it out.

(AM wires the circuits)

I: So, then, one prediction is that the first bulb will use up some of the electricity, the other prediction that you have is that they'll be even?

AM: Yeah.

I: Okay. So when you first wrote that out, you were thinking that would use it unequally? Is that what you're saying?

AM: Right. That this one would use up, and that would be left over.

(AM, initial interview, problem 2)

After observing the outcome of wiring two bulbs in series and comparing them to a single bulb, AM attempted to explain the results. His explanation resembled a model of shared current, which Shipstone (1985) proposes as a separate model:

AM: Through the whole circuit, there's only so much electricity going through, and it's going to, through here it's going to give out the same amount, I mean, there's only so much there in the whole thing, it's going to have a certain amount here (pointing to B) and a certain amount here (pointing to C).

I: Okay. Now does it look to you like this — which one's brighter of these two?

AM: A is definitely brighter.

I: Okay, why is that?

AM: Because this is the only one. It's not separating between another.

(AM, initial interview, problem 2)

YZ, too, began with a sequential model, but like AM, was beginning to doubt it, due to the knowledge he'd gained in class. YZ had memorized several rules regarding current and voltage in parallel and series circuits, but was having some trouble applying the rules to actual circuits, and hence was having difficulty offering an alternative to the circular sequential model:

I: ...I'll have you wire this one so that we've got these two bulbs in series with the battery, and you predicted that B should be brighter than C in this circuit, and that A should be brighter than B. So do you still think those are what's going to happen?

YZ: Um, I don't know because I've never tried it before. But the reason I'm predicting it is since it's going in the direction you'd be taking more, having more electricity here (pointing to B) than when the electricity cannot, um, get to C. So logically there'd be more power going to B than C. That's what I thought. And um, no I don't think, no I don't

really think there's going to be a difference in, um, difference in the density of the light because they're in series.

I: So in series, what should happen? Should they be the same or different?

YZ: Well — in series, let's see — (thinks) what I remember he said is in series they're the same current but different voltages. And in parallel they're the same voltage but different current. (YZ, initial interview, problem 2)

Despite his initial doubts, however, the circular sequential model remained so strongly compelling for YZ throughout the term that even after wiring two bulbs in series and observing that they were equally bright in the final interview, he was sure that one was slightly brighter than the other. While he was capable of reasoning on a systems level, he often required prompting to do so:

I: Okay, so this should all look familiar. Here on this one you said that if we make the series circuit that B should be brighter than C. Does that seem right?

Y: B should be brighter than C. Yep.

I: Okay. Let's have you set that one up, using either one of those battery packs. Or both.

Y sets up the circuit. Observes the results.

Y: So the part of the terminal flow — looks a bit brighter to me.

I: Hm. What if you switch it the other direction?

Y: Those two?

I: Yeah. Does it make any difference?

Y: Oh, it will make a difference probably. (checks results). Hm.

I: What do you think?

Y: Just looks like this one's brighter to me (pointing to C).

I: Why would that be?

Y: I don't know. Probably (?). Um, unless — (tries moving wires, makes a circuit just with C, then puts wires back). Those two should be equal — it's supposed to be equally bright. I guess when two of the, um, my calculation on voltage and current — actually — you only divide those two. So the voltage should be the same. I had a miscalculation in my mind on that one. (YZ, final interview, problem 2)

KR had made predictions using the sequential model on his initial survey, and by the time of the interview, doubted his original model. However, he was reluctant to propose a new model:

I: ...here you predicted that B should be brighter than C, and that A should be brighter than B. So we'll use these two — we'll call this one A, and this one B and C. Do you still think that's what going to happen?

KR: Uh, let's see. B is brighter than C. Um — I'm not sure I do. Let's see. I think B and C — I can't remember. Um — well maybe I do. I could find out, but I'm not sure. (KR, initial interview, problem 2)

After seeing the results of his trial, KR struggled with creating an explanation using the knowledge he had learned in class. He ended the sequence with suggesting that current is shared between elements:

KR: So like I, yeah. Voltage goes across, current goes through, um — and if they're in parallel, if resistors are series you add them, if they're parallel it's a different process, but, um, the one we just did in class proved that in series the current stays the same. And in parallel the voltage stays the same. So that would mean that the current in these two are the same, therefore — voltage across them would be different but they're the same brightness because the same current is passing through both. I believe.

I: Okay, and why are they less bright than the other?

KR: Because they're sharing the current. It's a constant current, but it's lower because it's divided by two. (KR, initial interview, problem 2)

Transitional

AK, who scored well on the initial survey, held a transitional model in the initial interview. While many of his explanations were systemic in nature, his initial explanations about a series circuit involved the idea of current being “used up,” though AK was not quite satisfied with this because it did not reconcile with other ideas he had about the circuit:

I: Okay, so why is that? Why are the two in series less bright than the single one?

AK: Ah — let’s see — um, because — (long pause) the electrons are used up here and here (B and C). Um, wait. That doesn’t quite make sense with my analogy of the electrons going through. Yeah, I’ll stick with that. The electrons are used up here and here (B and C) instead of all here (A). So, um, that’s why these are half as bright, or less bright.

I: Okay, so there’s something flowing — let me make sure I’ve got this right — there’s something flowing through here and you’re saying that’s electrons.

AK: Um, hm.

I: And they’re being consumed by those?

AK: Um, they’re being — let’s see. Yeah. Yeah. I’ll go with that. Half the electrons are being used by that one (C) and the other half are being used by that one (B).

I: Okay.

AK: Which doesn't quite make sense, because what goes back to here? (Pointing to battery) Um, but, ah, so — hm. See half of them are being used, and um, I don't know how they get back to here. They're being used to heat that up, but uh, and make it bright. And then they go through the circuit and through this one as well. Um, as to why they're dimmer than that one, let's — hm. Hm. Well. Yeah.

I: So something about the idea of them getting used up isn't satisfying you?

AK: Oh, yeah. It's not. [laughs] But, I mean, they're going, running through that, but only half of them are — it's half as bright, because less electrons are going through there. I'm just trying to figure out why there would be less with two, instead of just the same amount going through — um, I mean, I could always just say less volts across, but that's just, like, a complicated term, volts. (AK, initial interview, problem 2)

In addition to a linear model of a single-bulb circuit made on her initial interview, MJ made predictions about bulbs in series from the point of view of a sequential model. When predicting the brightness of two bulbs in series, she predicted that the first in the circuit should be brighter than the second, reasoning that the first would use more current, leaving less for the second. But by the time of the first interview, she was wavering between a sequential model and a non-sequential model — she tended to approach the

problem first with a sequential point of view, then catch herself and apply the knowledge from class. By the end of the term she was using the sequential model less, but it was still evident in some of her statements; hence she was categorized as transitional at the end of the term. MJ expressed difficulty with the idea that current and electron flow are expressed in opposite directions, yet current was described class as electron flow. In her reasoning about circuits, she sometimes expected the direction of current to have an effect, and hence was sometimes puzzled about which direction current should be moving and what effect it should have:

MJ: (thinks for a while) I think this is what I did last time, too, because the electrons are actually flowing around from the negative terminal rather than from the positive terminal, and so they get to C first and then the current splits up and half of it goes this way and half of it goes that way so they don't have as much current going through them. But since we say that current flows from positive to negative, that still confused me. Is that actually right? (MJ, final interview, problem 3)

Yet in reasoning about simple series and parallel circuits, MJ could use a more systemic view with ease as with this excerpt when MJ was explaining a parallel circuit. On the survey she had indicated that a single bulb A would be brighter than two in parallel, D and E. In this passage, she applies her knowledge and reasons her way to an explanation of her actual observations:

I: Okay, so then would you say A is brighter than D or as bright as or—?

MJ: I think they all look about the same. But what did I put? A is brighter than D. And that's wrong. Yeah, this would have made more sense for how I had it wired before [series circuit], what I wrote. Would have made more sense for that. But like if we were trying to solve this circuit, the voltage across E would be the same as the voltage across the battery, which would be the same as the voltage across D, and then in A, the voltage across the battery is equal to the voltage across A, so they would all have to be the same. (MJ, final interview, problem 2)

JF, like MJ, began and ended the term in a transitional state. JF had considerable experience with wiring electric lights in houses, and had learned from experience that wiring lights in series isn't the best plan when trying to install multiple lights in a living space because it causes all the lights to be equally dim:

I: Yeah. So your prediction was that B and C should be equally bright, and if we compare A and B, A would be brighter than B. Does that still sound like a good prediction?

JF: I still believe that. Yeah.

I: Okay. Go ahead and wire that.

JF: I don't know why I believe that, but I believe it.

(JF wires the circuits.)

I: Is that something you've experienced before?

JF: Yeah. Not in this small of a scale. I was using 110 and I wanted four lights in a row under a loft I built, and it didn't work out. Course it could have been my wires I used also. [finishes circuit, observes the results] Yeah. Too much resistance involved. (JF, initial interview, problem 2)

However, though JF had an intuitive sense of the behavior of simple circuits based on his experience and could correctly predict the outcomes of most of the problems on the survey, he tended to think of current as quasi-material, as in the earlier quote in which he described how he'd thought, on the initial survey, that current could get backed up behind a resistor like water behind a dam, thus increasing the resistance "after" a bulb would cause the bulb to be brighter. His reasoning about circuit throughout the term tended to be influenced by an underlying and persistent concept of current as a material-like something that flows, in spite of his ability to define "current" in terms of energy, while he struggled with the mathematics involved in creating and solving circuits. This appeared to make the transition to a non-sequential model difficult for JF, who in the final interview expressed his awareness of his own learning and his need to learn to think more in the abstract:

JF: And I don't think we had enough of that in class, like, because I'm a hand-on learner, that's me 100%, my whole life, that's all I've been. I've been on a farm, and you've got to go do a project, if you can't do it with tools you've got, you improvise, but it's all hands-on... Like I wish college was nothing but no books, just hands-on, because I don't learn it. I was telling someone I can go do a job right now and I can guarantee you give me three months hands-on training, I'll be just as good as the person with the degree. Maybe I won't understand the concepts as much, but I can do the work, okay, I can figure it out. And that's what this is, is just a lot of learning stuff that you can't really ever apply. A lot of the big huge math problems, you can't actually apply them to physical things, and that's why I'm having problems with it. And I don't know if that's going to be just this course. It might be everything I try to do. I might have to learn to be more abstract thinker. (JF, final interview)

AM, who began the term using a circular, sequential model, moved to a transitional state by the end of the term. Like JF, AM tended to unconsciously cling to the idea of current as quasi-material, even though he described current in terms of energy. While he correctly predicted the outcomes of series and parallel circuits, and could explain the results in terms of resistance, his explanation of a problem involving three bulbs, two in parallel connecting to a single bulb, contained elements of a sequential model:

I: So A is indeed brighter than B and C. So how does that work in terms of voltage, resistance, current going through the circuit, how is it that these two are less bright than this one?

AM: Um. I'll say since because each light is equal, in like theory, the resistance that it takes, so it's gonna make B — it's going to change the current and voltage, and in this one there's only one, here there's two — (breaks off, looks up)

I: Okay

AM: There's twice as much. Resistance. (AM, final interview, problem 2)

I: Okay. So they are equal brightness. C is definitely brighter. So why are these so very dim, and that one so very bright?

AM: (thinks) Um, well, say if this was like one light bulb (pointing to A and B). It would have to equal the same amount as coming into this one. Amount of what, I don't know. Voltage, or current. Um, so, they're going to equal the same. And, but, this one has to divide it, because they're in parallel, so both of them are a lot dimmer than that. (AM, final interview, problem 3)

The idea that current is something that flows appeared to make it difficult for students to let go of the idea that the direction of current flow mattered, and that the behavior of elements in relation to other elements depended on whether they were “upstream” or “downstream” of one another. It was not difficult for students, through experience, to understand that bulbs wired in series would be equally bright, and to explain why, but when solving more complex circuits, students who remained transitional tended to think first about the direction of current flow, and this often influenced their ideas of the outcome.

Non-sequential interrelational model

Out of the seven subjects, two held a non-sequential interrelational model of circuits by the end of the term. TA, in fact, demonstrated a non-sequential model from the start of the term. TA had been in the Navy and had taken several months of training in electrical engineering. This had taken place about ten years prior to enrolling for ECE 112, and though TA had forgotten many of the details, he still retained an overall model of circuits that closely resembled what was taught in the ECE course. TA also used more concepts in his explanations, relating voltage, current, and resistance, than did the other subjects in the initial interview:

I: Here you predicted —

TA: B and C should be equally bright —

I: And that A would be brighter than B.

TA: It's the same current — (reads over other choices) Well, I have the same current going through, but they have different voltages. And therefore different resistances. I'm still guessing A is going to be brighter. (TA, initial interview, problem 2)

On problems involving complex circuits, some idea of a sequential nature crept into TA's explanations, but his overall model tended to take the entire circuit and multiple concepts into account:

I: ...So you thought A and B should be equally bright, and A and C should be equally bright. Does that still seem like it ought to be?

TA: Um — yeah, I'm going to still say that.

(TA wires the circuit... TA finishes the circuit, expresses surprise)

I: Hm, so what's going on here?

TA: (long pause) These obviously are equally bright. But this — oh. (looks thoughtful) this has to do with resistance I think because they're parallel, these two are in parallel. Whatever the internal resistance is will be — (pauses) kind of (?) so it would be, these two res — the internal resistance of these multiplied by each other and divided by the sum and — I'm guessing the resistance — obviously it's different than C. But — it's going to be less resistance across each one of them. So — (laughs)

I: This one's a hard one. There's a lot to take into account in that circuit.

TA: With equal voltages, these two (A and B) have equal voltages and equal current. Because the same current flows into here, given that they're made equally, they have the same resistance so they'll each have equal current flowing through them. But the current splits off. So there's lower current going through these than through here. (TA, initial interview, problem 3)

AK, by the end of the term, had also let go of a large part of his sequential thinking and showed a strong preference for using a non-sequential interrelational model to explain complex circuits. His preference for using voltage, which he termed "push," in his explanations remained strong in the second interview:

AK: Well, um, it's, it's um, the battery's dropping the same amount of voltage across both of those, um, so, let's see. Well the battery can take either path, that path [A to C] or that path [B to C]. And what it ends up doing is it does both at the same time, so it pushes across that one and that one [A and C], and it pushes across that and across that [B and C]. So while it's putting like half the energy across each of these [A and B] it's putting the full amount of energy across that [C] because it's pushing

across this way, it's pushing across this way. (AK, final interview, problem 3)

Table 10 indicates the models of simple circuits held by each of the seven subjects during the initial and final interviews.

Table 10: *Distribution of student models around simple circuits. Full explanation of the categories is in the text. "1" indicates the initial interview, "2" the final interview. Subject MJ is shown as having two initial models because the linear model showed up on her survey form, but she had discarded it for a circular sequential model by the time of the first interview.*

Models of simple, series, and parallel circuits	A M 1	A M 2	Y Z 1	Y Z 2	M J1	M J2	K R 1	K R2	J F 1	JF 2	A K 1	A K 2	T A 1	T A 2
Linear					X									
Circular, sequential	X		X	X	X		X							
Transitional		X				X		X	X	X	X			
Non-sequential interrelational												X	X	X

Branching circuits

Problem 6 was particularly problematic for nearly all students who took the survey, and for most of the subjects in this study. In this problem, students were shown a circuit with two bulbs and two dry cells wired in series, and a switch across the middle of the circuit (Figure 8).

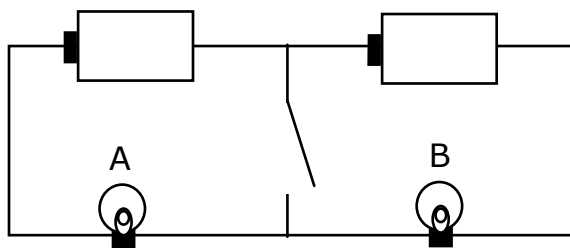

Figure 8: Diagram shown in problem 6 on the survey form, which proved problematic for most students.

Students were given several choices to check regarding the behavior of the bulbs if the switch in the middle were connected, including whether A would get brighter or dimmer, B would get brighter or dimmer, both would go out, or that nothing would happen. The problem came from Mazur (1997), which stated that the correct answer was that nothing should happen because if the switch were closed, there be no current flowing across the switch because there is no voltage difference across it.

The problem was difficult to demonstrate using the current board, as imperfections in the equipment and differences in battery freshness often created slight flickers in the bulbs when the switch was depressed, which subjects took as confirmation of some of

their alternative models. Nevertheless, it was possible to get students to talk about their predictions and why they believed that they should see the effects they had predicted.

Six of the seven subjects of the study thought that one or the other of the bulbs should change brightness. Their reasons varied, but fell into these categories:

- Brightness should change because one bulb gets both batteries and the other does not.
- Brightness should not change because the switch creates two separate, independent circuits.
- Brightness should not change because there is essentially no current across the switch.

Brightness should change because one bulb gets both batteries

If subjects held a strongly sequential model, they tended to believe that one bulb or the other should get more current when the switch was connected. Their answers were often simultaneously complex and hazy as they tried to trace the path of current in the direction that they expected it to flow, believing that one bulb should in some way have more access to current than the other.

I: So what should be happening here when you complete the switch?

How does that change the circuit?

YZ: You just get a better current. You've got more um— to the light bulb — by just looking at the picture on what I thought before when I

first did this, why I assumed that it went through the (?) terminal that if this was connected, you have one current go from here to be, one current goes from A to B. Which would create better, brighter light bulb, but hm. It seems like —

I: Where is A getting power from?

YZ: A is getting power from both batteries. And um — hm. I would like to think the current actually comes through this way, but that would probably be weird. And from if it's coming from that one, if you assume the current as a whole it doesn't matter and um since they're all connected and there's— there would be only one more connection in the middle between those two you shouldn't have any change in them. (YZ, initial interview, problem 6)

I: Okay. It's all lit up. So what's going to happen once that switch is pressed.

KR: Um — they both should get brighter.

I: And why would that be?

KR: Because — they should get brighter but it would last as long, because you're, um, you're basically splitting it up into two circuits, where — I think. Where, um, the current from this one and this one are going, yeah. So this one is going through — basically each one has two batteries in series instead of in parallel? Um. So you get the current from

this one and the current from this one. I think. (KR, initial interview, problem 6)

Brightness should not change because the switch creates two independent circuits

In this model, which was most common among the subjects, the switch is viewed as a divider that separates the circuit into two independent circuits, connecting each bulb to its own battery, but completely separating the bulb-battery pairs from one another. When questioned, subjects indicate with hand motions the direction of the current in these separate circuits as moving generally clockwise, in spite of the fact that if current did flow as they indicate, it would have to move in opposite directions across the switch. Subjects generally did not think of this without prompting.

After observing the results in the initial interview, KR switched to this model in his explanation of what he was seeing:

I: Okay. It's all lit up. So what's going to happen once that switch is pressed.

KR: Um — they both should get brighter.

I: And why would that be?

KR: Because — they should get brighter but it would last as long, because you're, um, you're basically splitting it up into two circuits, where — I think. Where, um, the current from this one and this one are going, yeah. So this one is going through — basically each one has two

batteries in series instead of in parallel? Um. So you get the current from this one and the current from this one. I think. (KR, initial interview, problem 6)

In the initial interview, JF began with the model of a divisible circuit:

JF: Cause — basically what you're doing with this switch — what it looks like you're doing is individualizing the circuits. Instead of running two battery packs with two batteries you're just pretty much having two individual circuits. This for this one, and this for this one. (JF, initial interview, problem 6)

JF applied similar thinking in the final interview, but when questioned more closely, began to doubt his model:

JF: Well right now you have — assuming these are the same of course, the two batteries are powering two light bulbs. When you, in one circuit, when you divide the circuit in half, you divide it evenly in half, you divide it right down the middle, so — now you have twice as much voltage here when you cut it in half you're dividing it in half, you're sharing it in half, too, so it stays the same.

I: So how does the current go once that switch is thrown?

JF: Which direction?

I: What path does it take?

JF: I uh really don't know. I believe it goes like this and then like this (indicating two separate circles with his finger — independent circuits). I believe it can flow both ways through this.

I: So it goes —

JF: I think it can do that.

I: Cross directions?

JF: No. It might just do that (around in a circle) I don't know. I really don't. Let me think about this for a second. Cause I never figured out current flow, why it flows in the directions, and if you talk about AC, it can flow in two directions ...Um. If uh [reads the survey form silently]. You know what probably happens? Probably nothing. I still stick to the nothing happens. Why, I'm trying to think about it more. Possibly because it doesn't do anything, because current can't flow both directions. It still continues to use the main circuit. It doesn't go through there.

Brightness should not change because there is essentially no current across the switch

The only subject to use this model without prompting was AK, who was able to use his concept of voltage as “push” to solve the problem in both the initial and the final interview:

AK: Um, those two batteries are pushing together against those two lights, and when you flip the switch, um, one battery could push that way

and one could push that way, but those pushes cancel, so they still (draws circle on diagram with finger). They still push the same amount. (AK, initial interview, problem 6)

I: So how does the current — if I close the switch there, how would the current move through that circuit?

AK: Um, well — let's see - the current could try to push across here [the switch] and try to go that way, and try to go this way (drawing two individual circuits with his finger on the diagram).

I: So we have current going both ways?

AK: Exactly. So I think that nothing would happen because it would — the same amount of push — or there would be more push here [indicating going “down” the switch] than there would be here [going “up” the switch]. So instead of anything going that way through, or, actually there'd be the same amount of push. If it went this way it would use up — I don't know that one. It would have the same amount of current as if that were closed and they weren't they weren't — the same part. So because of that it tries to go that way but there's the same amount going the other way so it, just, goes around instead [indicating going entirely around the circuit]. So if you close it or open it, nothing changes, because current can't go both ways, because it just — instead of it going both ways, it just goes forward. (AK, final interview, problem 6)

Table 11: *Distribution of student models around branching circuits. Full explanation of the categories is in the text. "1" indicates the initial interview, "2" the final interview.*

Models: Branching circuits	A M 1	A M 2	Y Z 1	Y Z 2	M J1	M J2	K R 1	K R2	J F 1	JF 2	A K 1	A K 2	T A 1	T A 2
Difference: current distributed differently	X		X				X							
No difference: circuit divided in two		X		X	X	X		X	X	X			X	X
No difference: no change to current											X	X		

Table 11 indicates the models of branching circuits held by each of the seven subjects during the initial and final interviews.

Summary

All subjects began the term with alternative conceptions or underdeveloped concepts around the concepts of interest: circuits, current, voltage, and resistance. Students also demonstrated alternative conceptions regarding the functioning of batteries and bulbs. In many cases, students simply lacked any developed ideas around these concepts. Their conceptions expressed were often conceptions of the moment as they struggled to use the terms in a way that made sense given their prior experience and their use of the terms in lecture and lab. The basic concepts of current, voltage, and resistance were addressed in the first week of the term in lecture and in class notes. Subjects used these terms

throughout the course and in each lab. and were expected to understand and apply the concepts as they worked on their lab projects and solved problems in lab and in lecture. Nevertheless, several of the study's subjects still held alternative conceptions regarding these concepts at the end of the term. Using and applying the terms had not been sufficient to move them to a more scientific view.

A material view of current, though not necessarily a conscious conception, colored most subjects' thinking. Students were told in lecture and in the class notes that "current consists of moving electrons." It is possible that students have a strong tendency to think of electrons as particles, and hence think of current as a moving stream of particles, from which they would logically conclude that current, or electricity itself, is a material or at least has qualities of a material. The class notes also noted that current is the flow of electrical charges, but students did not express this view in interviews. Current is an abstraction, and students in this setting tended to think of current in concrete terms, using the water flow analogy. Students with a sequential model of circuits had a particularly strong image of current as something with material properties that reached some circuit elements "first" and was "used up" by those elements, or that a resistor "downstream" from a bulb would not affect the bulb. Expectations of current being "used up" may stem from their experience with batteries, which lose their charge over time.

Voltage was a difficult concept for all students at the start of the term. Even by the end, not all students had a view of voltage that fit the target concept in the class notes. Students often confused or conflated voltage and current. They measured voltage in class, but did not have a clear idea of what they were measuring. Potential energy is an

abstraction, and the complex relationship between voltage, current, and resistance left students confused — for example, students who learned that voltage drives current expected higher voltage to produce higher current, but had trouble reconciling this to the fact that higher resistors restricted current but had higher voltage across them. Current tended to be the preferred concept in explaining the behavior of circuits, and some subjects moved to using voltage as the preferred concept at the end of the term. A model of voltage involving pressure or "push" often had scientific inaccuracies in it, but was a fruitful model for several subjects who used this model to solve lab problems and explain problems during the interview. Two of the subjects used a mathematical model of the relationships between concepts which served as a functional model for solving problems.

Concepts around resistance revealed an essentially material view of current, as students described the current being “held back” by resistors. The restriction of flow was seen as analogous to the restriction of water flow in a narrow pipe. Both views require a concept that electrons are moving in a stream and somehow this flow of electrical “material” is impeded in its flow by the resistors.

The overall model of circuits that subjects used related to their views of current as material or energetic. Students with a more materialistic view tended to favor a sequential model, while those who used a more energetic view tended to develop a non-sequential interrelated model.

The purpose of this study was to record student knowledge about electricity, not to evaluate whether students reached a scientific understanding. Rather, the purpose in documenting student knowledge was examine its effects on performance in the task-

based lab. Student use of knowledge as they solved problems and reasoned about electricity during lab was examined by constructing concept maps of their knowledge during each observation in order to describe the body of meaningful knowledge that emerged during the labs, as described in the next section.

Subject Use of Knowledge During Reasoning

All subjects were observed and videorecorded for at least three lab sessions. Not all lab sessions yielded adequate data about how students were using their knowledge to solve problems. In the first labs, students were following instructions to assemble their robots, and most of their conversation with the researcher and their neighbors were about mechanical details of assembly. In the final lab, students were constructing controls for their robot and again much of the conversation was about construction, though here students had to plan and build their own circuits. After the tapes were transcribed and reviewed, the researcher used the subject comments and actions to create a set of statements that summarized the subjects' expressed understanding of electrical concepts. The statement list was used to create a concept map for each observed lab, depicting the body of knowledge that students applied to each problem and the links students made between concepts. Concept maps were also created for the initial and exit interviews. This allowed comparisons to be made between the initial knowledge set, meaningful knowledge applied to the lab problems, and the knowledge set that emerged at the end.

Subject AM

Subject AM was observed three times in lab, but two of the labs involved AM assembling parts according to written instructions and the conversations around this yielded little data. While working on Lab 2, however, AM carried out a conversation with his lab partner that yielded statements about the target concepts.

AM entered the course with a low score on the survey of electrical concepts, little past experience with electrical concepts in classes, and some experience in assembling electronics at home. The highest level of math that he had taken was MTH 252, Integral calculus, the second course in a year-long series of introductory calculus. A concept map of his knowledge that emerged from the initial interview (Figure 9).

The map reflects AM's limited knowledge at the start of the term, as the concepts used and the connections between them are fewer than what emerged in the final interview, which one would reasonably expect of a student who enters a class with little prior knowledge about electricity, then spends ten week studying electrical concepts. AM's knowledge of voltage was unclear, and he used the term "voltage" very little in the initial interview, not unusual for students with low electrical knowledge who may be more familiar with concepts of current than voltage and resistance. His initial guesses about what voltage might were that it was something to do with a measure of current:

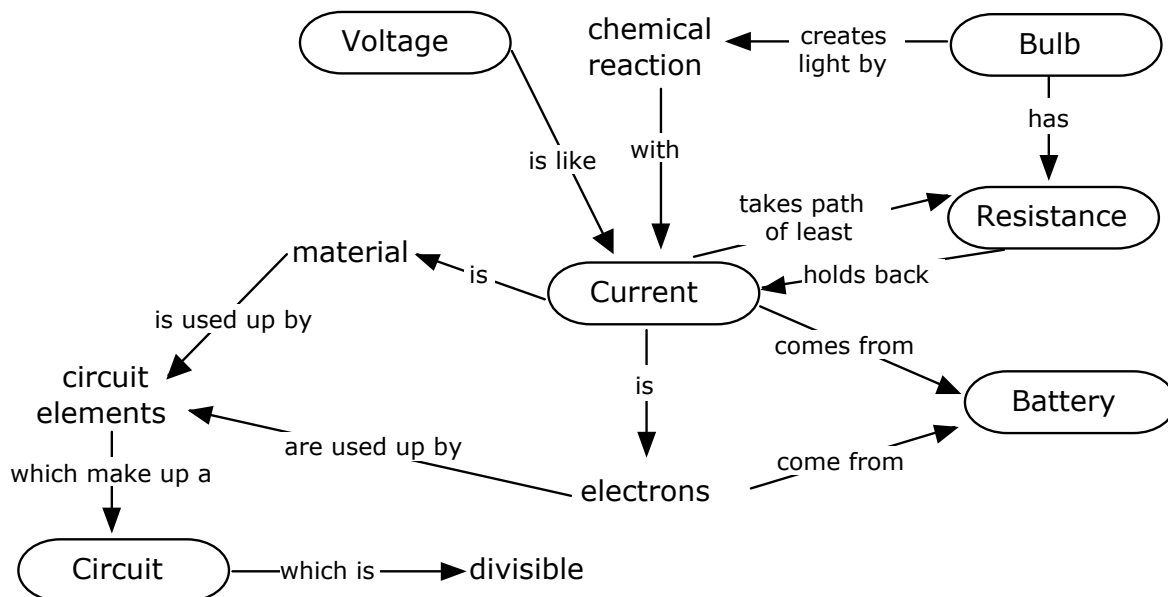

Figure 9: Concept map for AM, initial interview.

I: For instance, you measure voltage in lab.

AM: Right.

I: So what do you picture yourself measuring?

AM: (long pause) The — number of electrons at a give moment?

(Looks back at I)

I: Okay. So when it says it's such-and-such volts, or when you measure so many volts across a resistor, we're measuring electrons with them.

AM: Uh, no. (thinks) Hm... The current would be the flow of electrons, and R, resistance is how many electrons are being held back, er, not how many, it's just, just a number. I mean, 4.7 ohms, it's not

going to hold back 4.7 electrons. So yeah, I guess it makes sense that voltage would be the number of electrons. (TA, initial interview)

Most of his discussion involved describing current, which he understood to be the flow of electrons, and to be highly directional. His view of current was material, as he described current being “used up” by bulbs and other elements in the circuit. This may be related to the concept of current as the flow of electrons, which students often picture as material particles. This may also have been related to his idea that a chemical reaction between electricity and something in the bulb made the bulb light up. In AM’s view, current came from the battery where it was stored, and traveled through wires to the circuit elements, where it was used up. Resistance involved holding back the material flow of current in some way, and the position of the resistor determined what effect it would have on the circuit:

K: And if we increase this resistor, that it should stay the same. That still seem logical?

AM: (thinks) Yeah.

K: Okay. And why is that?

AM: Um, this resistor comes after the bulb, so it would have no effect on the, um, flow into the bulb. (AM, initial interview, Question 5)

Compared with the initial interview concept map, AM's map for the first observation (Figure 10) reveals less attention to the concepts themselves and more to the practical application of the concepts in lab. In this map, AM had altered his ideas about batteries to include batteries as a source of "power" (which AM did not distinguish from current) and as a source of voltage. By this time AM had measured the voltage of the batteries and was aware of the voltage printed on the battery label. At one point during the conversation, AM noted that if his partner wasn't getting voltage measure on a circuit that they had built, then the circuit might be incomplete; hence voltage is only detectable in complete circuits where, presumably, current is flowing.

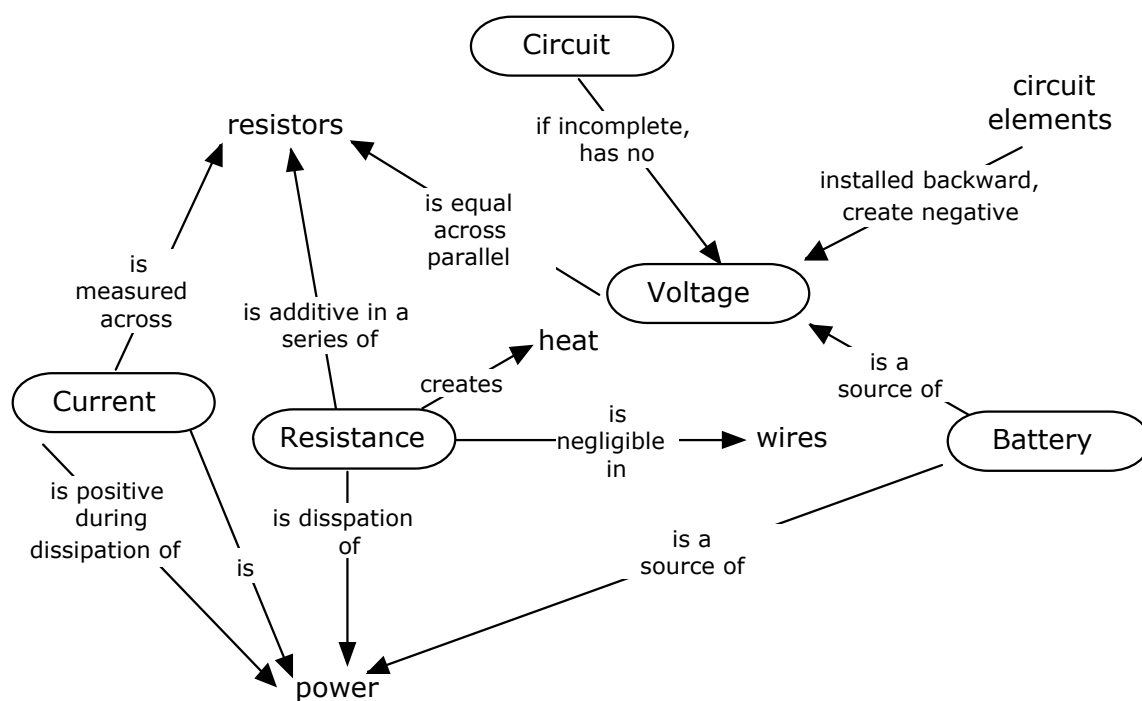

Figure 10: Concept map for AM, Observation 2

However, voltage readings could be affected by the polarity of installed circuit elements. If these were installed backwards, AM noted that he obtained a negative reading for voltage. AM also discovered through experience that installing a diode backwards caused it to heat up to the point of smoking, and thus learned that the polarity of circuit elements was an important consideration.

One of the lab activities included inserting resistors into a prototyping board in both series and parallel formation, measuring voltage across them and current through them, and noting whether they felt hot or not, thus directly experiencing the dissipation of energy. Students then used the voltage and current readings to calculate the amount of power dissipated in watts. AM referred to the lab instructions frequently and expressed resistance as the dissipation of power, which was the point of the exercise. AM stated that he expected voltage to be the same across parallel resistors. Having learned the concept in a prior lecture, he was able to apply the knowledge to the problem. AM also successfully predicted that one large resistor would dissipate as much heat as several small resistors in series, and easily solved the lab problems involving additivity of resistance in series circuits. Again, AM was applying knowledge learned in lecture.

However, AM's attempts to measure voltage and current were hampered when he failed to distinguish between the methods for measuring voltage and current, and persisted in attempting to measure current across a resistor. Instruction from the teaching assistant was necessary for AM to understand that the multimeter had to be wired into the circuit in order to measure current, and that simply turning the dial to amps and touching the probes to the resistor, as AM attempted to do, could cause the fuse to break.

What is interesting is that little of the knowledge that AM demonstrated in the initial interview were expressed as he worked on the problems in this lab. This may have been because AM was unsure of so many concepts, and that concepts taught in lecture had more direct value to him than the concepts he initially held. Further, AM's focus was on using the concepts rather than defining them; hence most of the links between concepts relate to the observed effects of voltage, resistance, and current on the circuits he built and observed. A few of his initial concepts, however, appear related to the connections he made between concepts in the lab. His essentially material view of electricity as the flow of electrons, and the idea that current flows in a particular direction, was reinforced by his discovery that circuit elements have polarity, and that a reversal of current causes a negative reading on a multimeter when there should be a positive reading, and vice versa. This was the only part of the initial knowledge set that became meaningful for AM as he worked on this lab.

In the exit interview (Figure 11), AM showed more developed concepts of voltage and resistance, though the number of interactions between concepts remained about the same.

Some misconceptions emerged in the interview, indicating that though AM's concepts were more developed, he was still struggling to grasp some of the target concepts taught in class. For example, AM understood that voltage was the result of resistance in a circuit, but thought that voltage was some kind of way of measuring current. Yet the idea he expressed, that voltage has to do with the change in the flow of electrons, did have elements of an understanding of potential differences:

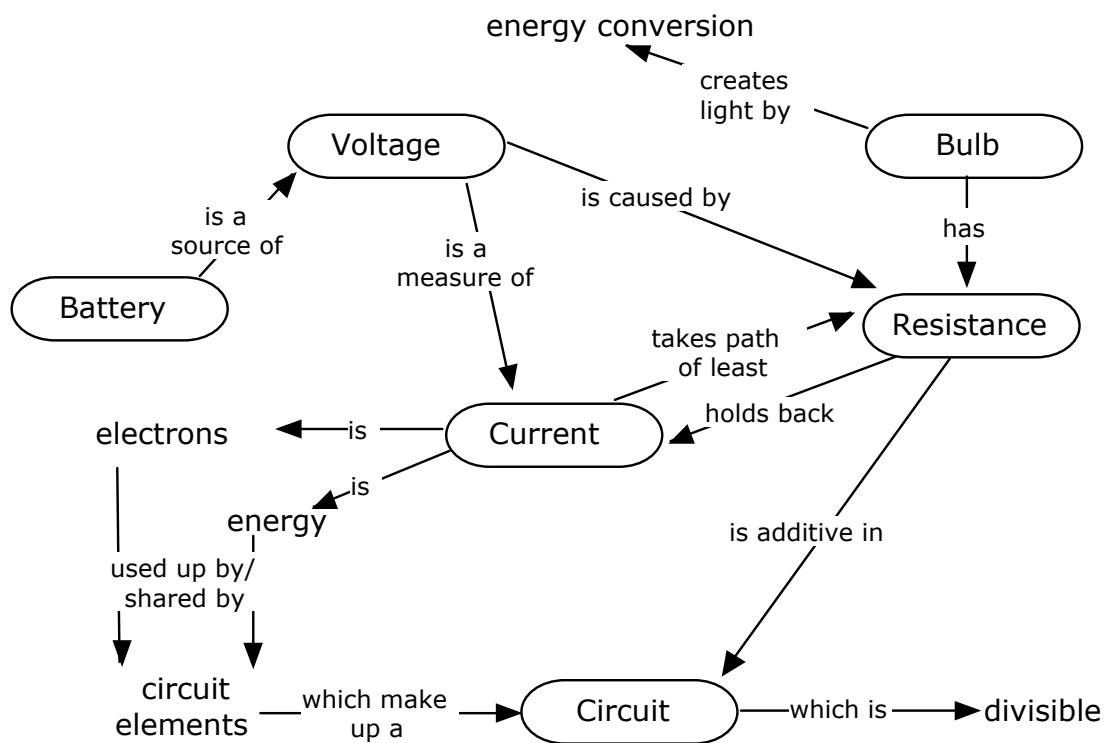

Figure 11: Concept Map for AM, exit interview

I'm going to say it's the change of, um, like electrons flowing. Not flowing. Just the like either the drop or the increase between one point and the other. (AM, exit interview)

Thus AM had some understanding of what voltage did and how it behaved, but not what it actually was. Again he described current as an electron flow, and expressed an essentially material view that current was something that was consumed by circuit elements. His concept of resistance was very close to the concept expressed in the first

interview. Given that he had spent a large part of Lab 2 learning that resistance involved the dissipation of power, it was interesting and a little surprising that this concept was not voluntarily expressed in the interview. He did, however, understand that light emitted from a bulb was the result of the conversion of electrical energy to light energy, due to resistance. AM understood that the resistance of a single resistor affected the entire circuit and correctly predicted that increasing either resistor in Question 5, where a bulb was wired in series with two resistors on either side of it, would cause the bulb to dim. He had also moved from a model of a battery as a source of current to a battery as a source of voltage that moves current, a concept used frequently in lab.

Table 12: *Summary of AM's knowledge about the target electrical concepts (circuits, voltage, current, resistance) across the term.*

Knowledge stated at the start	Meaningful knowledge: observation 1	Knowledge stated at end
<ul style="list-style-type: none"> •voltage is like current •current is a material that is used up by circuit elements •current is electrons which come from the battery •resistance holds back current •current takes the path of least resistance •light in a bulb is created by a reaction of chemicals with current 	<p>From interview</p> <p>None of AM's statements in lab overtly contained knowledge from the initial interview.</p> <p>From other sources</p> <ul style="list-style-type: none"> •voltage comes from the batteries •voltage is equal across parallel resistors •resistance is the dissipation of power •resistance creates heat •wires have negligible resistance •resistance is additive when resistors are in series •current is measured across resistors 	<ul style="list-style-type: none"> •voltage is a measure of current •battery is a source of voltage •voltage is caused by resistance •bulbs have resistance •bulbs convert electrical energy into light energy •current takes the path of least resistance •current is the flow of electrons •current is energy •current is used up by or shared by circuit elements •resistance holds back current

In Table 12, the body of AM's meaningful knowledge is summarized across the interviews and observations. Because the interview situations involved asking students

for their understanding of particular terms, the knowledge gained in that situation encompassed both meaningful knowledge (spontaneously used) and inert knowledge (that which was recalled when asked for). Knowledge that was expressed and used in lab spontaneously is listed here under “meaningful knowledge” for the lab observation.

Subject YZ

Subject YZ was observed three times in lab. During the third observation, YZ was assembling his robot and did not engage in enough conversation about concepts to yield a good map, but the first two observations revealed the progress of his conceptual understanding and reasoning during the term. Because YZ was an international student and English was not his first language, care had to be taken in interpreting his statements so that difficulties with the language itself were not interpreted as difficulties with the concepts.

YZ entered the class with no prior coursework involving electrical concepts, though he had some experience in building a computer. The highest math class that he had taken was MTH 252, Integral calculus, second course in a year-long introductory calculus series.

Figure 12 shows a map of YZ’s conceptual understanding at the beginning of the term.

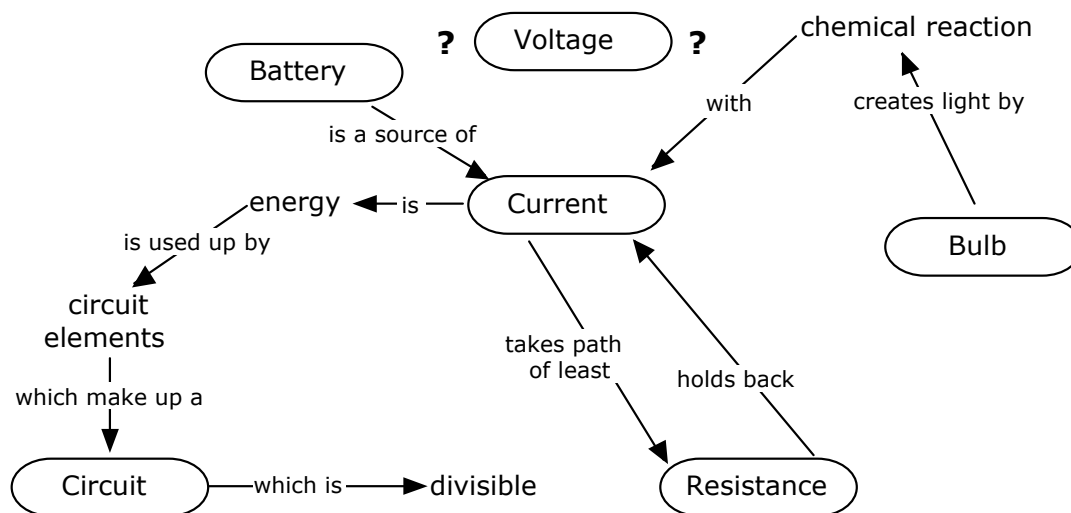

Figure 12: Concept map for YZ, initial interview

Most of YZ's conversation about the behavior of the circuits he observed involved descriptions of moving current. YZ was unable to describe what voltage was, and stated that he did not have a clear understanding of voltage; hence voltage, though present on his concept map, was not connected to the other concepts. In his statements about current, YZ described current as a kind of energy, and described it being used up by circuit elements such as the bulbs; however, like AM, YZ believed that light in a light bulb was caused by the interaction of current with a chemical in the bulb. His concept of current and of energy in general appeared to have material elements: current was stored in and came from the battery and was used up in the circuit. Resistance in the circuit served to hold back or impede the flow of current.

See, this makes sense. This makes sense because it's kind of —

because the battery puts out much more electricity than, you know, that

the light bulb can use up. Therefore it's kind of like using the same battery for two — it is like going between two separate light bulbs. So that makes, that sort of makes sense. (YZ, initial interview, Question 2)

Figure 13 shows a map of concepts that YZ employed during the first observed lab. YZ was beginning Lab 2, in which he was to learn about the properties of resistors, and Ohm's Law to calculate current, voltage, and resistance, and to calculate power dissipated from resistors.

Here, YZ was beginning to develop initial concepts about voltage. In his conversations with neighbors and the teaching assistants, he described voltage as moving through the circuit, indicating that he thought of voltage as something like current, in spite of his statements in the initial interview where he described voltage as being a measure of current.. YZ also thought of resistance as something that removed or reduced voltage. However, his view of voltage as like current relates closely to his initial concept of current as something that is consumed. He knew that voltage was measured with a voltmeter; however, he had considerable trouble understanding how to use the voltmeter to measure voltage.

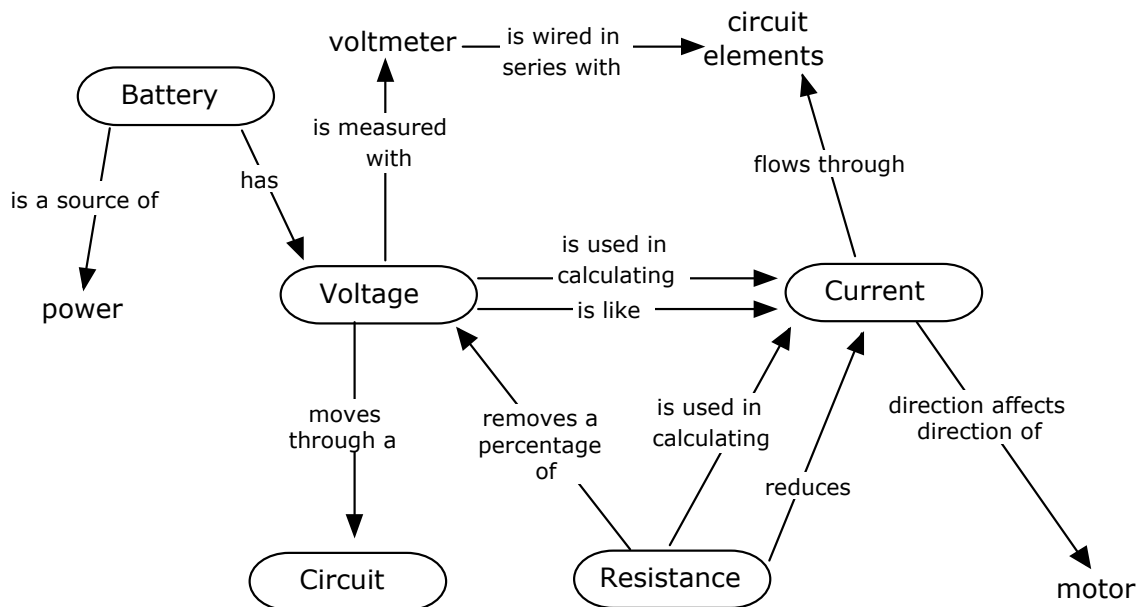

Figure 13: Concept map for YZ, Observation 2

In his first attempts to wire a circuit that included the robot motor and a resistor, he wired the voltmeter in series with the resistor, causing the fuse in the meter to break and a resistor to start smoking. In fact, his tendency throughout the lab was to wire various elements in series even when the schematic showed a parallel arrangement, a tendency due more to his lack of experience building circuits from schematics than a conceptual misunderstanding, since he recognized the difference between series and parallel circuits in the schematics themselves. A teaching assistant came to help him several times in lab and spent time helping YZ interpret the schematics and wire his circuits, and spent considerable time explaining the difference between measuring voltage across a resistor and wiring an ammeter in series to measure current.

Once he had measurements of current and voltage, YZ was adept at plugging them into Ohm's Law to carry out required calculations in the lab. His concept of current as something that flows directionally, a concept present in the initial interview, was expressed frequently throughout the lab, and applied when he predicted that changing the direction of current would change the direction that the motor turned, hence changing the direction of the wheels.

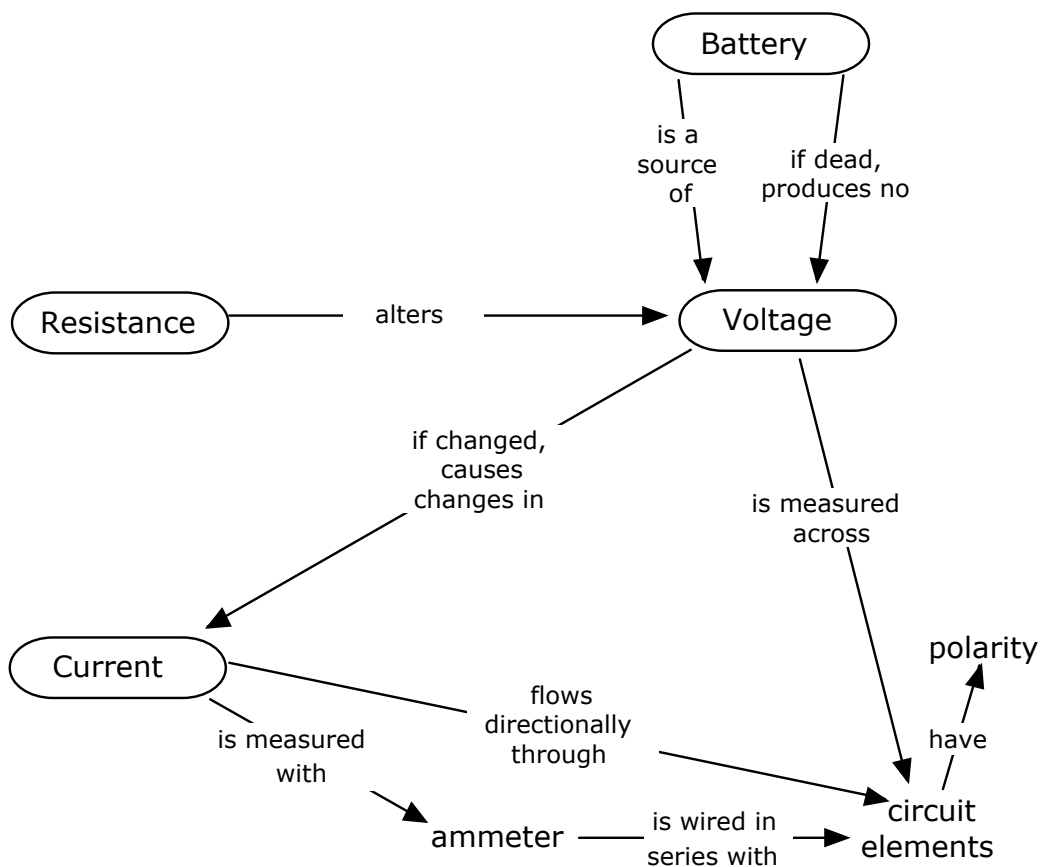

Figure 14: Concept map for YZ, Observation 3

A concept map of a second observation with YZ is shown in figure 14. In this lab, students were using diodes and zener diodes to understand their properties and how they could be used to control voltage, to create switches, and eventually how they might be used in creating digital logic circuits. YZ was just beginning this lab, and worked with a partner on portions that required two multimeters to measure voltage and current simultaneously.

YZ began the lab working alone, and as in the last lab, had difficulty translating the schematic into an actual circuit. A teaching assistant helped him as he began the lab, and a lab partner assisted him in the exercises in which they worked together. In the first circuit that YZ put together, he wired three resistors in parallel that needed to be in series. He understood how to measure voltage across a resistor, but was unsure how to correctly wire the ammeter in series, and given his experience when he wired a voltmeter in series, was understandably reluctant to do so.

YZ had learned by hard experience that voltage must be measured across a resistor, while current is measured by wiring an ammeter in series with the circuit. He expressed this several times and demonstrated this as he and his partner worked together to create a circuit in which a potentiometer was used to adjust voltage in a circuit that included a diode, and created a graph of the changing voltage and current through the diode. YZ was highly aware of the necessity of installing the circuit elements in the correct direction in regards to their polarity. He also expressed relationships between voltage and current, stating once that if there was no current that there would be no measurable voltage, and the reverse, that if voltage measured zero across a resistor, that there should be no

current. While he did not express a strong sense of what voltage was, YZ did state that the battery was the source of voltage, and that a dead battery would have no voltage. His understanding of resistance had also altered; whereas in the prior lab he thought that high resistance should reduce voltage, perhaps because he thought of voltage as something like current, in this lab he noted that a larger resistance would create a larger voltage.

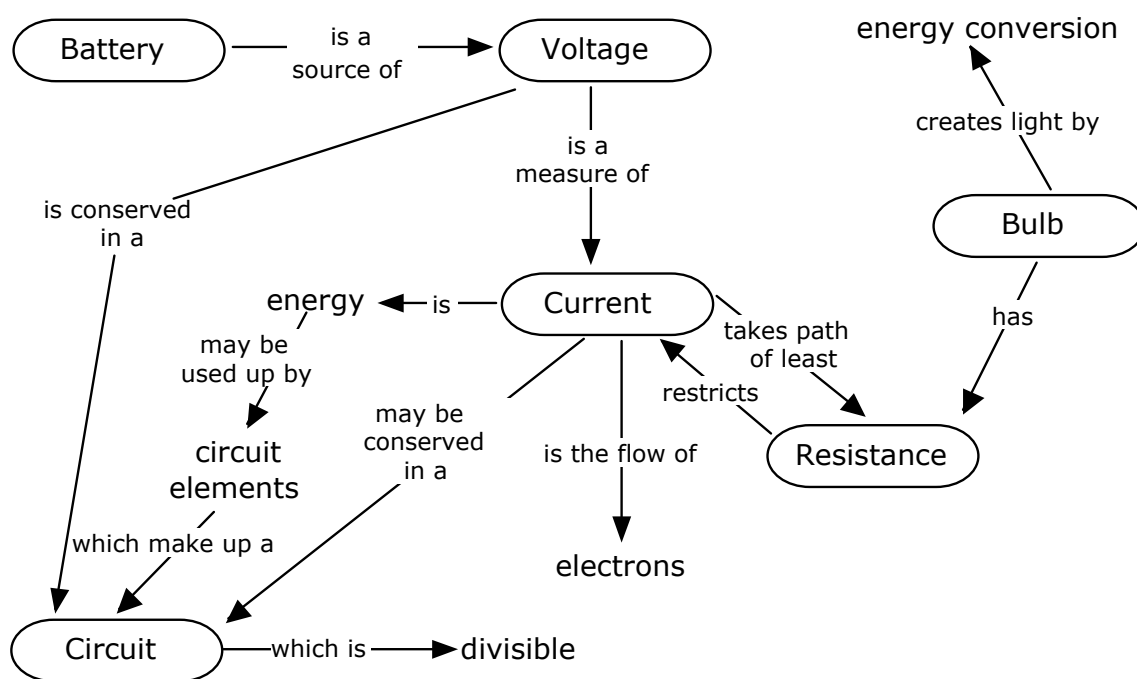

Figure 15: Concept map of YZ, exit interview

A map of YZ's knowledge in the exit interview (Figure 15) shows an increasing sophistication in his knowledge about electrical concepts and increasing connections between concepts, though with some misconceptions present. By the end of the term he had developed a concept of voltage, expressing voltage as a way of measuring current, though he appeared a bit unsure of this definition. He also had elements of the concept of

potential difference in his answer, indicating that he was assimilating this concept but was still unsure of what it meant:

I: Okay, so how do you define voltage in that case? What is voltage?

YZ: It's the um, amount of electricity flow, difference in, the electron flow difference on both sides of the node. Off a resistor or any part that's a dissipater. (YZ, exit interview)

His idea that the battery was a source of voltage seems at odds with his expressed definition of voltage, since a battery as a source implies voltage is something either material or energetic associated with the battery, while his stated definition implied that voltage was a type of measurement. Thus YZ's concept was still unformed and tentative at that point, as he worked to develop a practical understanding.

YZ's concepts in general tended to be strongly context-related. His interview responses related directly to the tasks presented in the interview just as his conversations during the lab observations related directly to the task on hand. His generalization of concepts tended to be limited to his concept of current as something material that flows through the circuit and is used up by the circuit elements, a persistent concept that did not alter during instruction. For YZ, the body of knowledge that became meaningful and was carried from one task-based learning context to the next remained small.

Table 13 summarizes YZ's changing knowledge and meaningful knowledge across the term.

Table 13: Summary of YZ's knowledge about the target electrical concepts (circuits, voltage, current, resistance) across the term.

Knowledge stated at the start	Meaningful knowledge: observation 1	Meaningful knowledge: observation 2	Knowledge stated at end
<ul style="list-style-type: none"> •battery is a source of current •current is energy that is used up by circuit elements •current flows •current takes the path of least resistance •resistance holds back current •current reacts with chemicals in the bulb to create light 	<p>From interview</p> <ul style="list-style-type: none"> •battery is a source of power. <p>From other sources</p> <ul style="list-style-type: none"> •battery supplies voltage. •current and voltage flows through circuit elements. •resistance removes a percentage of voltage. •resistance reduces current. •direction of current affects direction of motor. •voltage and current are both measured through a resistor. (Changed to “voltage is measured across a resistor” after instruction.) 	<p>From prior lab and interview</p> <ul style="list-style-type: none"> •battery supplies voltage. •resistance alters voltage. •current is measured through a resistor, voltage measured across •current flows through circuit elements. <p>From other sources</p> <ul style="list-style-type: none"> •changes in voltage cause changes in current. •circuit elements have polarity. 	<ul style="list-style-type: none"> •battery is a source of voltage. •voltage is a measure of current. •current is the flow of electrons. •current is a form of energy that is used up by elements of a circuit. •current takes the path of least resistance. •resistance restricts current flow. •light bulb converts electrical energy to light energy.

Subject MJ

Subject MJ, like AM and YZ, entered the class with a low level of knowledge about electricity and very little practical experience with electronics. MJ, however, had high math ability and demonstrated a meticulous attention to details, both of which she employed to advance rapidly in the class. The highest math level she had achieved was MTH 256, Applied Differential Equations. She was very open and vocal about her ideas during interviews and labs, providing excellent data for concept mapping. MJ had not taken ECE 111, the introductory course taught in the fall, because an advisor had steered her into a different class. Highly aware that she was behind her peers, MJ obtained the

materials for constructing a circuit board that had been a lab task in ECE 111 and assembled it herself at home and during lab.

A concept map for MJ's initial interview (Figure 16) shows some initial development of concepts, as well as some alternative conceptions. In this interview, MJ was unsure of exactly what voltage was. She had learned in class that it was something like pressure, though she did not make a link between the pressure and any specific effects. She noted that voltage affected bulb brightness, and that it was supplied by the battery. She had not yet made a connection between voltage and current, which was not unusual for other students entering the class. Hence her map shows a cluster of concepts around voltage and another around current, with little that links the two.

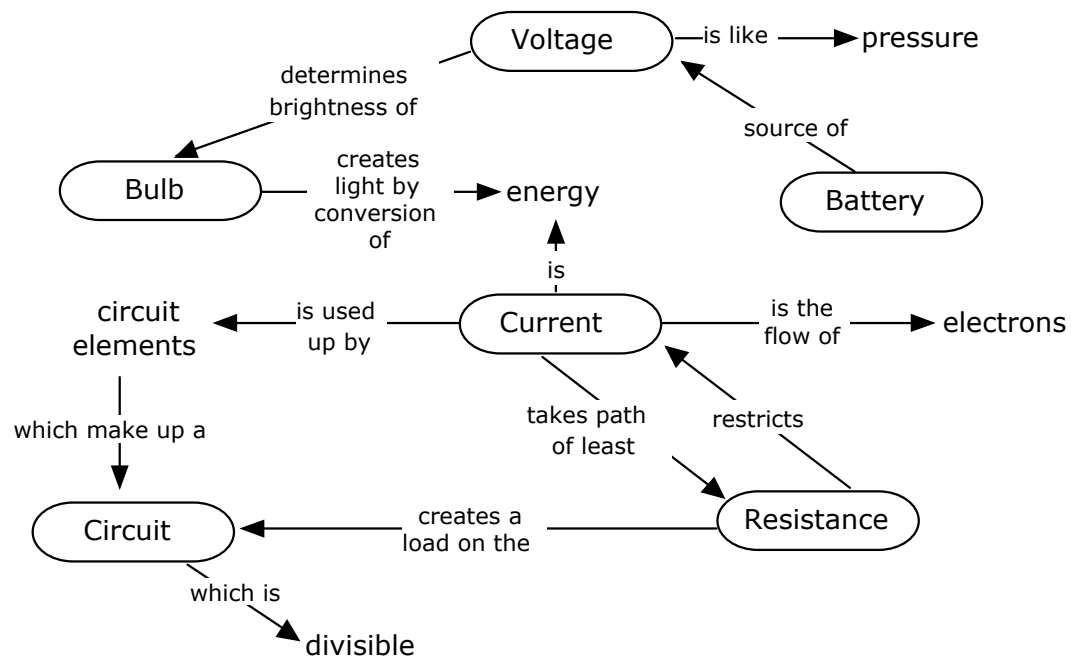

Figure 16: Concept map for MJ, initial interview

Like many students, MJ initially expected current to be “used up” by circuit elements, such that the first bulb in a series would be brighter than a second. By the time she reached the interview, however, she had assimilated some of the lecture material and was beginning to think in terms of voltage around the bulbs. She was unsure of exactly how voltage would affect bulb brightness, but thought that two bulbs in series would have the same voltage and so should have the same brightness, which she had not predicted on the survey:

It seems like they should be equally as bright, but, um — that's just my guess. (laughs) The reason that I would guess that is because it seems like the voltage would be determining the brightness of it, and it seem like if, the only way they would not be the same brightness is if there were something in the light bulb regulating it to say, you know, you're giving me too much voltage, I'm only going to take this much of it, but I don't think that that's really how it is. (MJ, initial interview, Question 2)

She thought of current as something that flowed directionally, a concept that remained strong with her throughout the term and that seemed to contribute to her puzzlement over the apparent conflict between current flow and electron flow. So long as she thought of both current and electrons in quasi-material terms, it did not seem logical to her that the two should flow in opposite directions.

That's something that I'm kind of confused — I think the electrons are going from negative to positive, but the way we always draw it is, you know, the current is always flowing from positive to — er, I mean it's going into the positive direction, so (pauses) I'm not really sure. I think it goes like this (moving hand clockwise). (MJ, initial interview)

The term “load” came up several times during the initial interview. MJ stated that resistors and bulbs created a load on the circuit, which affected current. While MJ did not explicitly state that bulbs were resistors, she talked about them as creating load and affecting the circuit in ways similar to her conversations about resistors, so it is probable that she recognized that bulbs create resistance. Her preferred term, though, was “load,” a term that was used in lecture and in the written class notes.

During the first observation (Figure 17), MJ was completing Lab 2, and finished early. Her robot platform was complete, and she spent some time working on the circuit board that had been the assignment for the fall course.

During this observation, MJ expressed a strong awareness of the polarity involved in circuit elements and batteries, and the dangers of installing things backwards. While handling a neighbor's robot, she was reluctant to plug in a power source, stating that if she plugged it in the wrong direction she could damage something. Her strong awareness of directionality of current flow that she had at the start of the term, combined with warnings in lecture about how students might “smoke” resistors or chips by installing them incorrectly, added to her caution. She stated to the researcher that she'd figured out

what fuses were for and how they worked, and gave an explanation, stating that a fuse has resistance and is designed to melt if there is too much current.

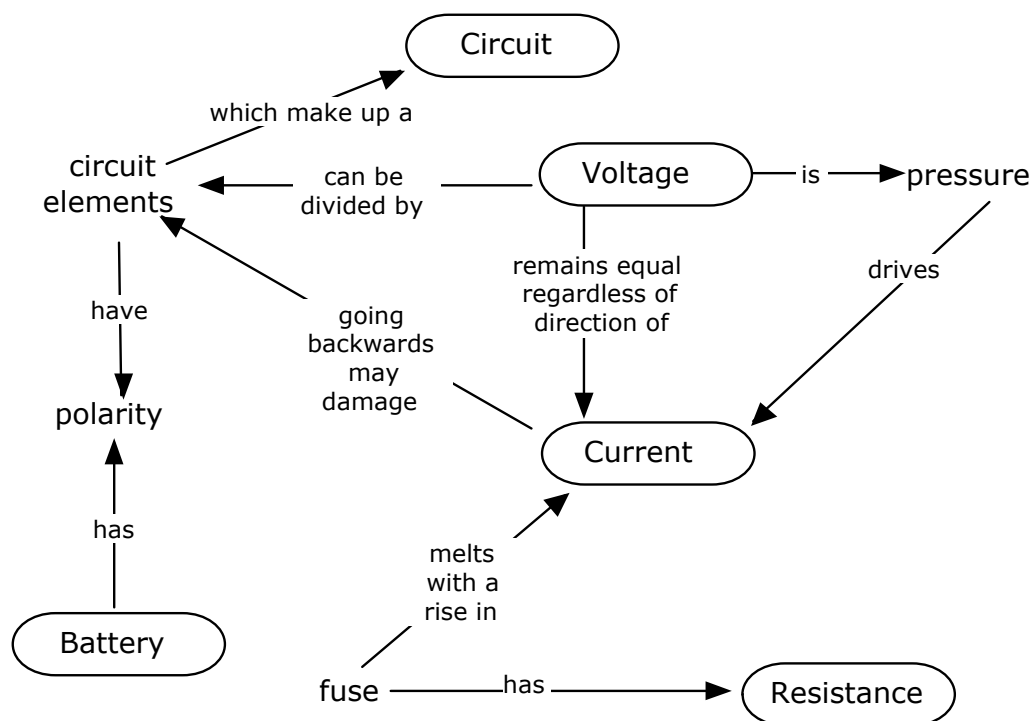

Figure 17: Concept map for MJ, Observation 1

MJ had also developed the idea that voltage was some type of pressure that drove current, and that the voltage itself wasn't affected by the direction of current. She viewed voltage as something that could be shared by or divided between circuit elements, as she had heard of using voltage dividers in circuits.

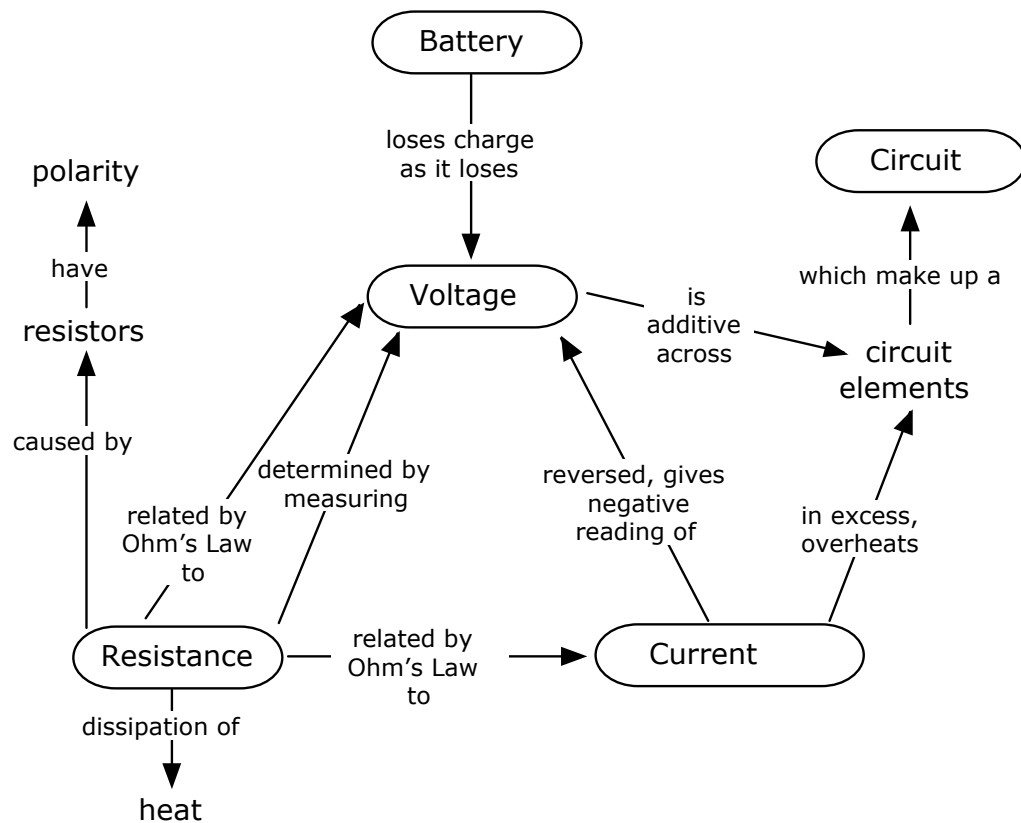

Figure 18: Concept map for MJ, Observation 2

In the second observation, MJ was working with another subject, AK, on Lab 3. In this lab, the two worked together on creating circuits with resistors in series and parallel in order to measure current going through and voltage across the resistors and to understand the relationship between current and voltage in each type of circuit.

Because the lab involved touching the resistors to see if they were hot or not, MJ expressed strong awareness of resistance as involving the dissipation of heat. She knew that too much current could cause something to overheat, again expressing the strong awareness of the cautions delivered in lecture about “smoking” their resistors. MJ was adept at using Ohm’s law to calculate resistance, voltage, and current using

measurements taken in class, and often used the multimeter to double-check the resistance of resistors she was using, as well as using the colored bands on the resistors to determine their resistance. The batteries she discussed very little except to mention that the voltage decreases with the charge. Like other subjects, her discussions around these concepts were more situational than theoretical: less about what voltage and current were than what they were doing at the moment. Nevertheless her expectations about the basic concepts did in some cases influence her approach to the activities. For example, her concepts of directional current flow influenced her to always check that she was installing resistors and other components in the right direction.

In a third observation (figure 20), MJ's links between concepts were growing more complex. MJ's awareness of one-way current flow was evident as she and her lab partner discussed how diodes work. Again she expressed awareness that an excess of current would overheat the circuit parts, and exercised caution in assembling the circuits required for the lab. She explicitly identified the potentiometer as an adjustable resistor which was used to control the flow of current. She stated that voltage across the resistors in a circuit where they were wired in series represented the voltage of the entire circuit, thus demonstrating a knowledge that voltage was additive.

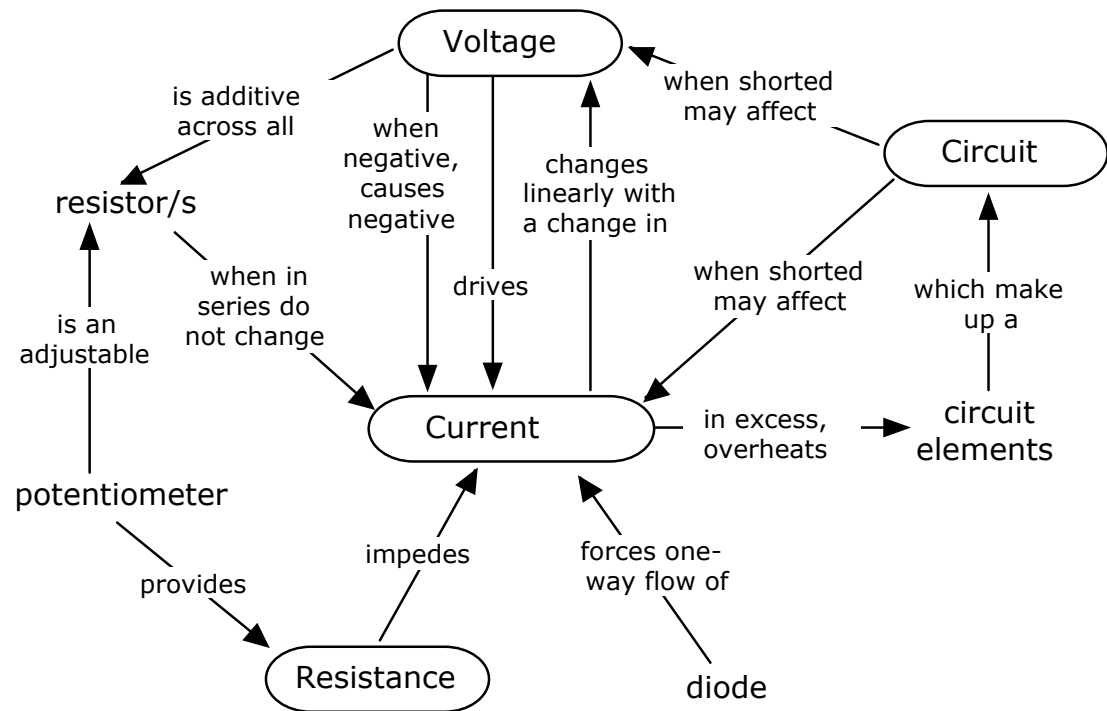

Figure 19: Concept map for MJ, Observation 3

Her concepts around voltage had increased. Again she recognized that voltage drove current, and expected that if she got a negative reading for voltage, she should get a negative reading for current as well. This expectation led MJ and her partner into an error as they took readings for voltage across and current through a diode. The diode was designed to act as a switch. When voltage was low, no current could get through the diode. When the voltage increased to a certain level, as adjusted by a potentiometer, current was allowed through. When current was graphed against voltage, the curve should have been flat, indicating 0 current, until the voltage was high enough to allow current through. At that point, the graph should have increased exponentially. MJ and her partner wired the circuit, but evidently made an error in their wiring. The diode in the

circuit was LED which should have lit when current was allowed through, but never lit as they took measurements. The resulting graph showed a linear relationship between voltage and current. To MJ, this made sense, since she knew that voltage and current were related, and where there was low voltage, there should be low current, and in a circuit without the diode this could have been true. Only after a teaching assistant pointed out that the graph was incorrect did MJ recall a graph drawn in lecture that resembled the graph she and her partner should have obtained. To explain why the circuit didn't work as it should, MJ drew on her knowledge of shorted circuits, hypothesizing that a short in the circuit somewhere could have affected the measured voltage and current. Later in the lab, she returned to this concept, checking for shorts in the circuit when there were unexpected results for measurements of voltage and current.

At the final interview, MJ's knowledge of electrical concepts had increased, as had her connections between concepts (Figure 21).

Her concept of voltage had moved from voltage as pressure to voltage as that which drives current, a slight but important difference in that the connection between voltage and current was more clear.

I: Okay, so what is voltage?

MJ: It's the change in potential from here to here (pointing to resistor on diagram) or from here to here or wherever you're measuring it from.

Change in electric potential. (MJ, exit interview)

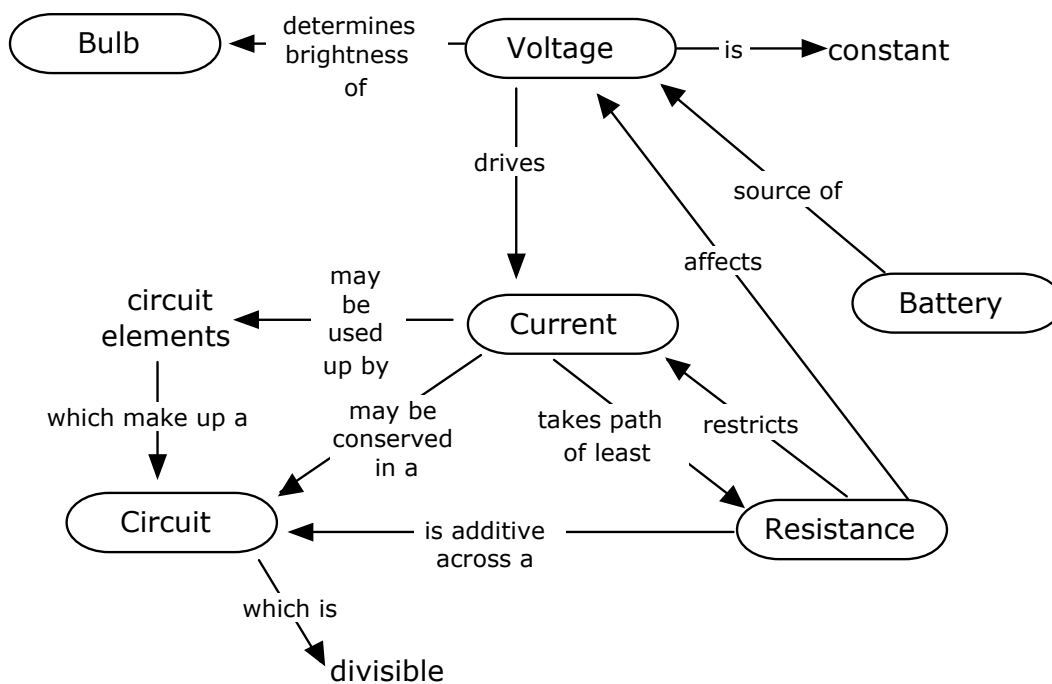

Figure 20: Concept map for MJ, exit interview

She also saw a clear relationship between resistance and voltage, recognizing that higher resistance was associated with higher voltage. MJ still had strong expectations about the directional nature of current, and had not quite let go of an image of current as something quasi-material that is used up by the elements in a circuit, as seen by her predictions that the first bulb in a series should be dimmer than the second, though she stated explicitly that both current and voltage were conserved in a circuit.

Table 14: Summary of MJ's knowledge about the target electrical concepts (circuits, voltage, current, resistance) across the term.

Knowledge stated at the start	Meaningful knowledge: observation 1	Meaningful knowledge: observation 2	Meaningful knowledge: observation 3	Knowledge stated at end
<ul style="list-style-type: none"> •voltage is like pressure. •voltage affects bulb brightness. •bulb converts electrical energy into light energy. •current is energy. •current is the flow of electrons. •current takes the path of least resistance. •current is used up by circuit elements. •resistance restricts the flow of current. •resistance creates load on the circuit. 	<p>From interview</p> <ul style="list-style-type: none"> •voltage is pressure. <p>From other sources</p> <ul style="list-style-type: none"> •can be divided across resistors. •voltage drives current. •circuit elements have polarity. •current in the wrong direction can damage circuit elements. •excess current melts fuses. •fuses have resistance. 	<p>From prior lab and interview</p> <ul style="list-style-type: none"> •battery supplies voltage. <p>From other sources</p> <ul style="list-style-type: none"> •battery loses charge as it loses voltage. •voltage is additive across resistors in series. •negative current produces negative voltage reading. •resistance, current, and voltage are related by Ohm's law. •resistance is dissipation of heat. •resistors have polarity. 	<p>From prior labs and interview</p> <ul style="list-style-type: none"> •voltage is additive across resistors in series. •resistance restricts the flow of current. <p>From other sources</p> <ul style="list-style-type: none"> •voltage drives current. •negative voltage causes negative current. •current changes linearly with voltage. •shorts in circuit affect voltage and current. 	<ul style="list-style-type: none"> •voltage is constant in a circuit. •battery is the source of voltage. •voltage affects bulb brightness. •voltage drives current. •current may be used up or conserved in a circuit. •resistance restricts current. •resistance is additive in a series circuit. •resistance affects voltage.

I: Okay. So why does it get dimmer if we increase R1?

MJ: Because well the voltage across the battery is equal to the voltage across this whole thing. But if R1 is greater, that's what we were increasing, then the voltage drop across this resistor is going to be greater, and there's going to be less voltage available to drop across this. So, it, um, it has to have voltage to drop here, so there's not much left in the middle.

I: Okay. But what happens when we increase R2?

MJ: If we increase R2, then there's going to be a higher voltage up here where the light bulb is, and — so the, um, it's going to lose some voltage here (points to R1), but it's going to have higher voltage here (points to bulb), and then it's going to drop the voltage across here (points to R2). (MJ, exit interview, Question 5)

Table 14 summarizes MJ's changing knowledge and meaningful knowledge across the term.

Subject KR

Subject KR entered the class with some prior knowledge of electronics from a physics class and a summer enrichment class in electronics that he had taken. The highest level of math he had taken was MTH 252, Integral Calculus. While his score on the initial survey was low, it was at the high end of the low range. Figure 22 depicts the concept map for KR at the first interview.

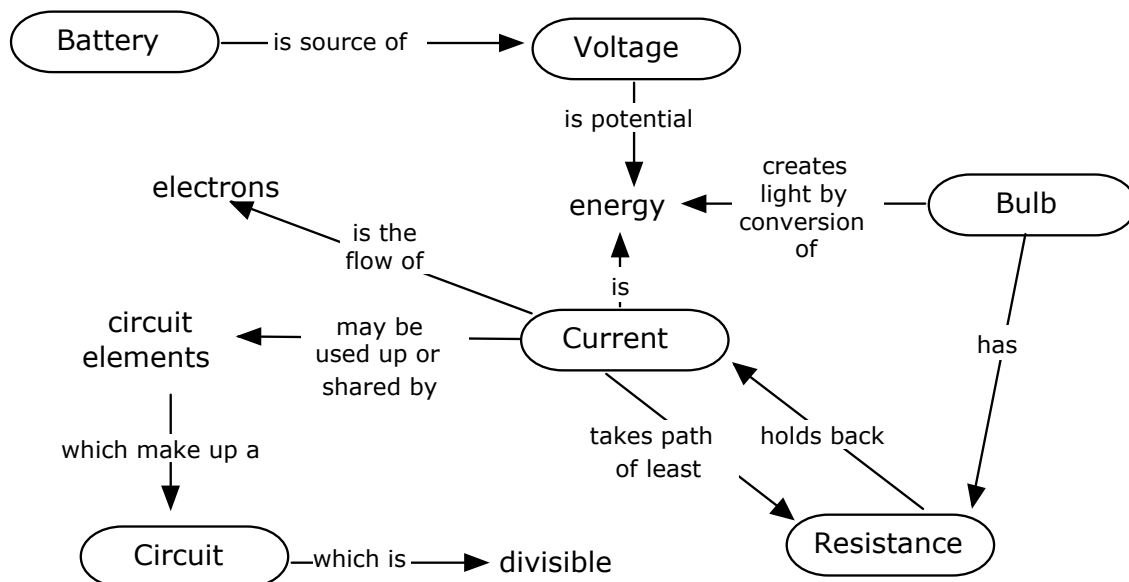

Figure 22: Concept map for KR, initial interview.

KR described voltage as potential energy, and noted that the battery was the source of voltage for a circuit. Current he described as electron flow, and no link was stated in the interview between voltage and current, so though KR described voltage as potential energy, it wasn't clear what he thought the energy did. Light in a bulb, KR stated, was caused by conversion of electrical energy into light energy, and he noted that a bulb was a resistor.

KR: All right, um, stored potential chemical energy is in the batteries, and um, like the description that I think was explained in class was like pool balls are filling the pipes up to the light bulb, so it's kind of like a chain in effect, you hit one and it sends the um current through the

circuit, and um, that current passing through the filament lights up and the filament releases heat and light.

I: Okay, so what's going on in the filament that's causing that to happen?

KR: In the filament. Um, let's see, the — it — the — the metal when electric current is passed through it um — I believe it can't contain that much energy so it has to release it, if I'm not mistaken. So it releases it in the form of light and heat. because it's in a vacuum, it does not actually blow up or burn up as it would if it were in the air.

I: Then where does voltage enter into this? You talked about current. Where's voltage?

KR: Voltage. Um, voltage is the — what exactly is voltage? Voltage is the amount of stored — of stored energy. I think. Um.

I: So if a battery is so many volts, what's that telling us?

KR: It can put out that much energy. It has that much potential to, um — yeah, to put out. So if it were fully charged it would put out 1.5 volts.

(KR, initial interview)

KR's predicted that the first bulb in a series would be brighter than a second, and he explained this in terms of current being used up by the first bulb. He also had a highly directional notion of current, and like most students, moved his hand in a circular pattern to depict the circular motion of current. Resistance, he thought, was where elements in a

circuit held back the current, preventing it from flowing. His sequential model of current flow turned up several times during the lab observations.

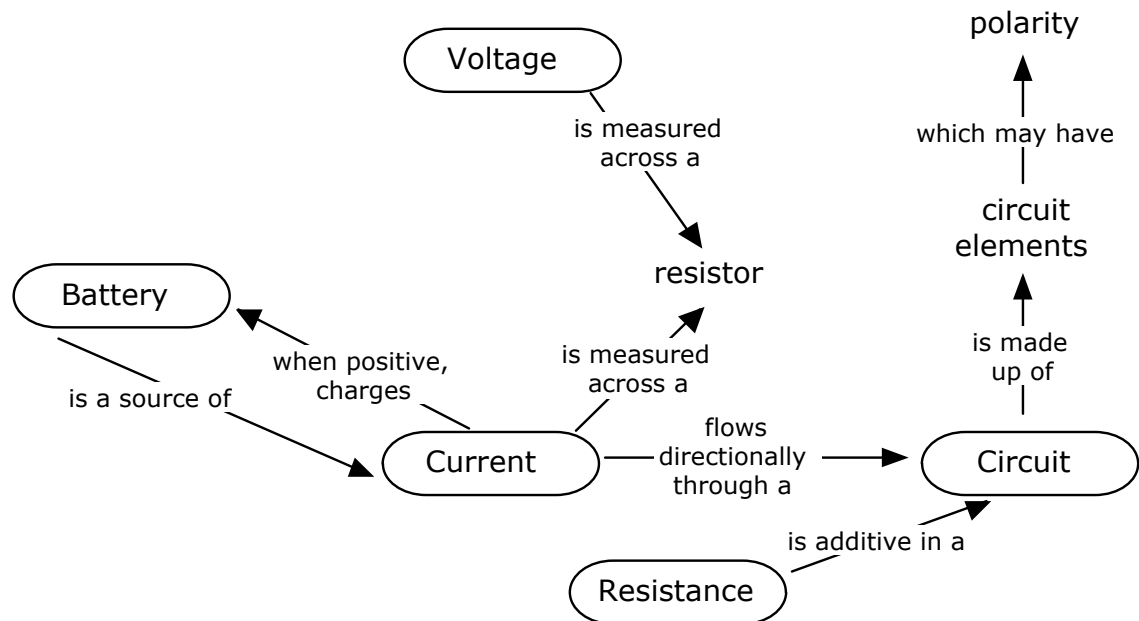

Figure 23: Concept map for KR, Observation 1

The first observation (figure 23) took place during lab 3. In this lab, KR was just starting the lab, beginning with creating two circuits to measure current and voltage in a simple circuit with the motor and the batteries of his robot.

To carry out the first exercise correctly, KR needed to wire an ammeter into the circuit, but measure voltage across a resistor in the circuit. The purpose of the exercise was to measure current directly and indirectly, and decide which was the most accurate way to measure it. KR's stated interpretation of the exercise was to wire a circuit with the motor with and without a resistor. He predicted that wiring a resistor into the circuit would make the wheels on the robot slow down. KR did not consider the ammeter itself

as a small resistor, even though the first step in the exercise was to determine the internal resistance of the ammeter, and had difficulty figuring out how to use the ammeter with the circuit. Like YZ, KR initially had difficulty in creating parallel and series circuits. He knew to measure voltage across a resistor, but when using the ammeter, his first thought was to use it measure current across a resistor. His neighbor stopped him, stating that he'd break a fuse if he used the meter incorrectly, and helped him wire the ammeter into the circuit. After measuring current with the ammeter, KR examined the diagram showing a voltmeter measuring voltage across a resistor and declared it was "the same thing." Again his lab partner explained the difference. When calculating current after measuring voltage, KR noted in his lab report that determining current by measuring voltage was less accurate than measuring it directly because the resistor was "in the way," again discounting the internal resistance of the ammeter.

The next exercises involved generation and dissipation of power. In this exercise, students created a circuit with a branch across it and a switch. By moving the switch, the student could use current coming in from the wall plug, or "wall wart" as it was termed in the lab, to charge the battery, or allow the battery to power one motor of the robot. KR began this exercise with a correct interpretation of the purpose of the activity. He did expect that the current coming from the wall wart and current coming from the battery would clash, but the teaching assistant explained that voltage would go from high to low, hence from the wall wart at 12 volts to the batteries at just under 8 volts.

As he set up his circuit, KR stated an awareness of the polarity of circuit elements, such as resistors, and was careful to put them into the circuit properly. He predicted that a

positive current flow at the point where he was measuring current would charge the battery. His neighbor corrected him and told him that a negative current flow was necessary to charge the battery. Closer inspection showed that KR had inserted two wires incorrectly, taking ground to be positive. After correction, KR obtained correct results for the circuit. He noted that when charged, the battery would supply current to the circuit. Here his quasi-material view of current was suggested: that the batteries “filled up” with current.

KR had time to just begin the next activity, in which he wired resistors in series and parallel and measured the voltage and current of each resistor. KR predicted that the total resistance of all resistors in series would add up to the resistance of the circuit, and of the batteries. He began the exercise with a statement that he should measure voltage and current across the resistors, but self-corrected, referring back to earlier exercises and the need to wire the ammeter into the circuit.

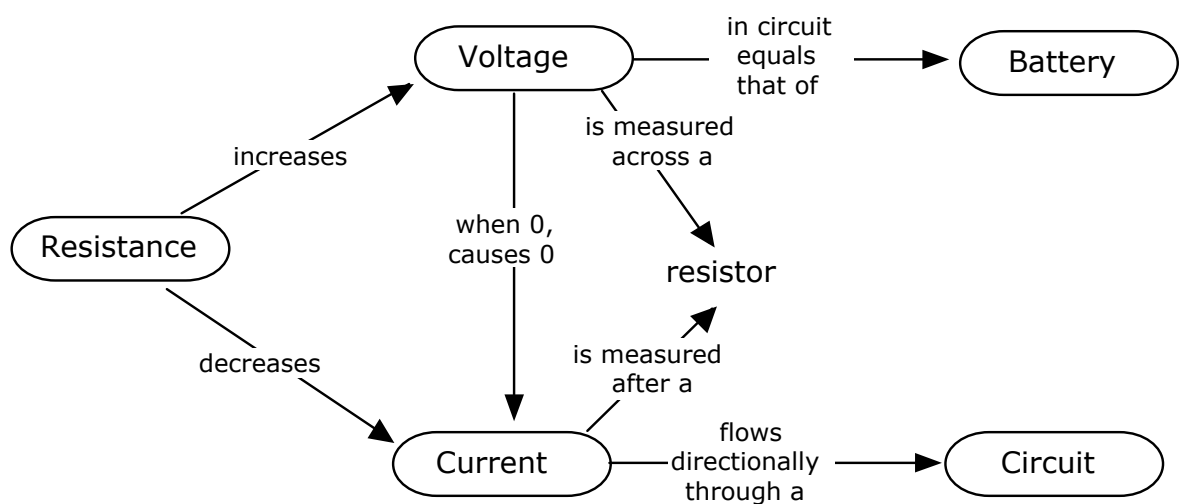

Figure 23: Concept map of KR, Observation 2

The second observation done on KR (Figure 24) took place during lab 4. KR had just begun this lab, and was working with another subject AK, to complete the activities. As they began, and were interpreting a schematic to build a circuit involving a transistor as a switch, KR noted explicitly that “current is measured through, voltage is measured across,” reciting what he had learned in the prior observation. Several times throughout the lab he noted how to unplug a wire in the circuit in order to wire the ammeter into the circuit. He also noted that an ideal multimeter had 0 resistance when measuring amps and infinite resistance when measuring voltage.

KR expected that increasing resistance should increase voltage, while decreasing resistance should decrease voltage. He also stated that where there was no voltage, there should be no current. The potentiometer served as an adjustable resistor, and KR’s expectations of a linear relationship between voltage and current led him and AK into the same error that MJ and her partner showed on this exercise. They wired the circuit as they thought it should be wired, but some part of the circuit must have shorted the transistor in the circuit, because the resulting graph showed current increasing linearly with voltage, when in fact, there should have been no current until the voltage reached a certain level. Their error was not discovered until the next lab, when a teaching assistant went over their lab papers with them.

KR then went on to the next exercise, which involved using diodes. KR noted that diodes restrict voltage as a hose clamp restricts water flow, applying an analogy for resistance to the regulation of voltage. As he prepared his circuit and showed it to the

teaching assistant, his sequential model of circuits emerged when he noted that current should be measured “after” a resistor rather than “before,” as the resistor itself would use up the current flow. The teaching assistant corrected this and explained that it really didn’t matter which side of the resistor the current was measured on.

A map of KR’s concepts at the exit interview (Figure 25) shows an increased complexity and sophistication to his concepts, in spite of lingering misconceptions.

His concepts about current appeared to still be forming. KR noted that the battery is a source of voltage, and that over time, it loses voltage, though he did not elaborate on the last point. His connection between voltage and current was mixed: when asked what voltage was, he defined voltage as a measure of current, while later he described voltage as something that drives current.

KR knew from experience that voltage should be measured across a resistor, but was unsure why that was:

I: Okay, then what I’ll have you do is measure the voltage across the resistor. Why do we measure voltage across resistors instead of just sticking it on a wire somewhere?

KR: Because voltage you can’t measure, well, yeah, you have to measure across, you have to measure the difference from one side to the other, basically. (KR, exit interview)

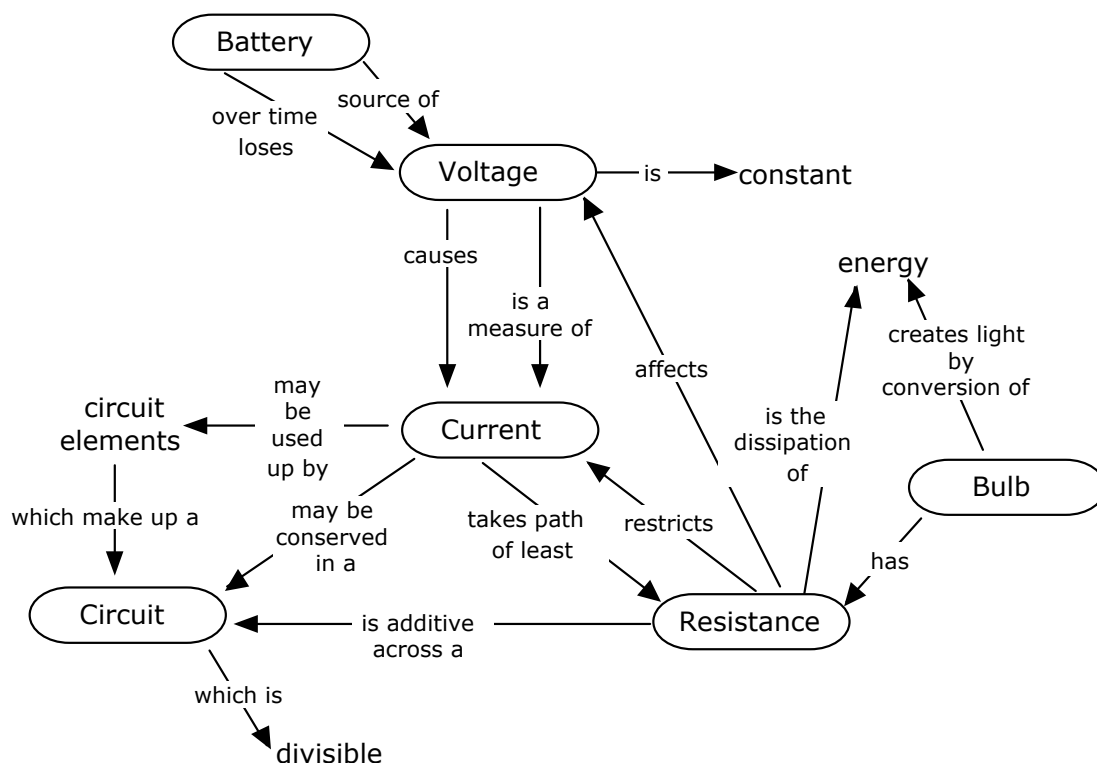

Figure 24: Concept map for KR, exit interview

His concepts around resistance showed increasing sophistication. Resistance he described as restricting current flow and increasing voltage. Resistance was additive across circuits, at least in series circuits, and resistors dissipated energy. KR was one of the few subjects who recalled this concept from his direct experience in the third lab with touching hot resistors.

I: Okay, and what does the resistance do to — do in that circuit? Can

I see an example of resistance in what the bulbs are doing?

KR: The, um, the light, the energy, the heat. It's basically dissipating some of the energy, some of it — [thinks] yeah, energy, um, from the batteries, and producing light and heat instead, just a resistor itself just produces heat. (KR, exit interview, Question 3)

However, KR's highly directional sense of current figured into his explanation for why bulbs in parallel are of equal brightness:

I: So what's different about that? These bulbs seem brighter than they were when they were wired this way. Why are they brighter wired in parallel?

KR: Because the, um, the current hits them both at the same time and isn't like, isn't reduced by hitting one first and then the other, so it's like, hm, can't think really now. But yeah. (KR, exit interview, Question 2)

While he described bulbs in series as being of equal brightness but dimmer than a single bulb in terms of the two bulbs having to "share" current, and he noted on his survey form that the two bulbs would be as bright as each other because they had the same current, his ideas around bulbs in parallel involve not only the same current, but that current reaching both bulbs at the same time.

Table 15 summarizes KR's changing knowledge and meaningful knowledge across the term.

Table 15: *Summary of KR's knowledge about the target electrical concepts (circuits, voltage, current, resistance) across the term.*

Knowledge stated at the start	Meaningful knowledge: observation 1	Meaningful knowledge: observation 2	Knowledge stated at end
<ul style="list-style-type: none"> •battery is a source of voltage. •voltage is potential energy. •current is energy. •bulb converts electrical energy into light. •current is used up by or shared by circuit elements. •current is the directional flow of electrons. •bulbs have resistance. •resistance holds back current. •current takes the path of least resistance. 	<p>From interview</p> <ul style="list-style-type: none"> •current flows directionally through a circuit. <p>From other sources</p> <ul style="list-style-type: none"> •voltage and current are measured across a resistor. (Corrected during lab.) •positive current charges battery. •battery is a source of current. •resistance is additive in a series circuit. •circuit elements have polarity. 	<p>From prior lab and interview</p> <ul style="list-style-type: none"> •voltage is measured across a resistor, current measured after a resistor. •current flows directionally through a circuit. •resistance is additive in a series circuit (total equals the resistance of the battery). <p>From other sources</p> <ul style="list-style-type: none"> •increasing resistance causes increased voltage and decreased current. •voltage drives current: 0 voltage means 0 current. 	<ul style="list-style-type: none"> •voltage causes current. •voltage is a measurement of current. •battery is a source of voltage. •current may be used up or conserved in a circuit. •current takes the path of least resistance. •resistance restricts current. •resistance affects voltage. •resistance is the dissipation of energy. •resistance is additive across a series circuit.

Subject JF

Subject JF began with a high score on his initial survey. His prior experiences in construction had given him a strong background in simple circuits, and he understood how light bulbs behaved when wired in parallel versus bulbs wired in series. He even explained that he'd wired lighting in a loft once and found out for himself that wiring the lights in series was not a good idea, because each light was much dimmer than he'd

expected. From this practical experience, JF correctly predicted that bulbs wired in series would be equally bright, but less bright than a single bulb, and that bulbs wired in parallel would be as bright as a single bulb. However, when it came to explaining why this happened, JF ran into difficulties, and his explanations revealed some alternative views around electrical concepts. The highest level of math that JF had taken was MTH 105, Introduction to Contemporary Mathematics, a course which precedes MTH 111, College Algebra.

In the initial interview (Figure 25), JF's ideas centered around his concept of current, which was an implicitly material view. He had little concept of voltage, though he'd heard the term, and seldom used voltage in his explanations during the interview. When asked about voltage, JF stated that he didn't really understand what it was, and was working hard in the class to try to form an understanding.

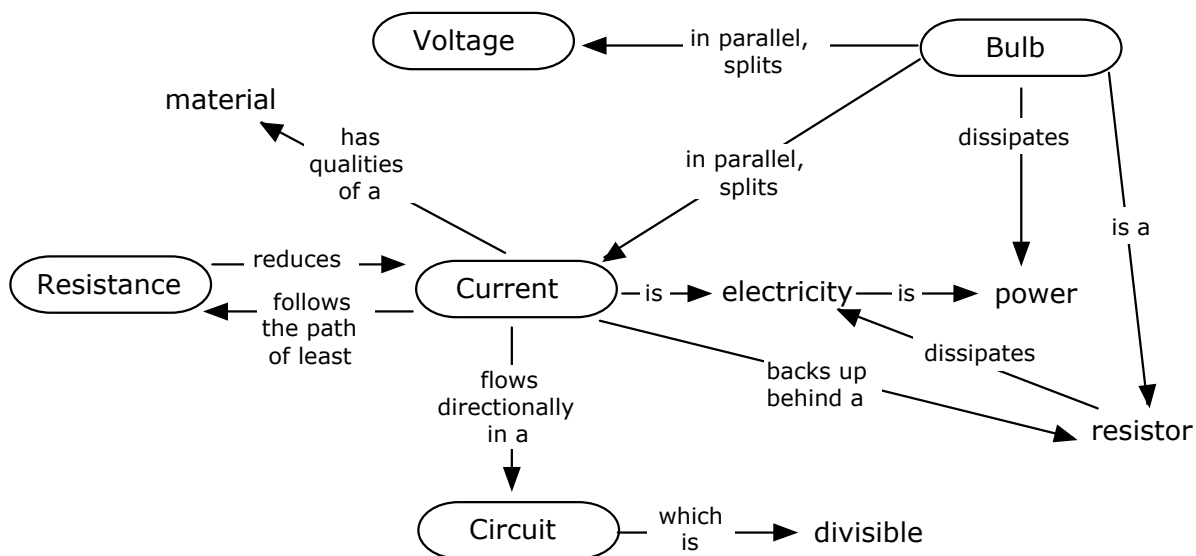

Figure 25: Concept map for JF, initial interview.

JF used the terms current, electricity, and power interchangeably, referring to current as “power or electricity or whatever.” One unique feature of JF’s views about current arose from his predictions on Question 5 of the survey form. JF believed that the bulb would be dimmer if R1 were increased, but brighter if R2 were increased. This he explained as a view that current was like water and resistors were like dams; therefore, current should accumulate behind the resistor:

If you — if this is dammed up, if you dam before the light bulb it’s going to get less, if you dam after it’s going to get more water.” (JF, initial interview).

This understanding implied a highly material view of current, with a strong sense of current flowing in a particular direction. By the time of the interview, JF had changed his viewpoint, and predicted that a resistor would have the same effect regardless of which side of the bulb it was on. He also recognized that bulbs themselves are resistors, and thus problem five depicts three resistors in series.

JF described both current and voltage being split between circuit elements such as bulbs, which seemed to be another aspect of a material view of current, and possibly an early development of a concept of voltage as being something like current. The term “voltage divider” was used in lecture, and students learned to wire resistors as voltage dividers in lab. It was not unusual for students to form ideas around voltage as something that flowed and was thus divided into different paths in the circuit.

At the first observation (Figure 26), JF was just beginning the third lab. He began the lab by measuring current in a circuit that included the motor, then wired a resistor into the circuit and measured voltage across it and used the measure of voltage and the size of the resistor to calculate current.

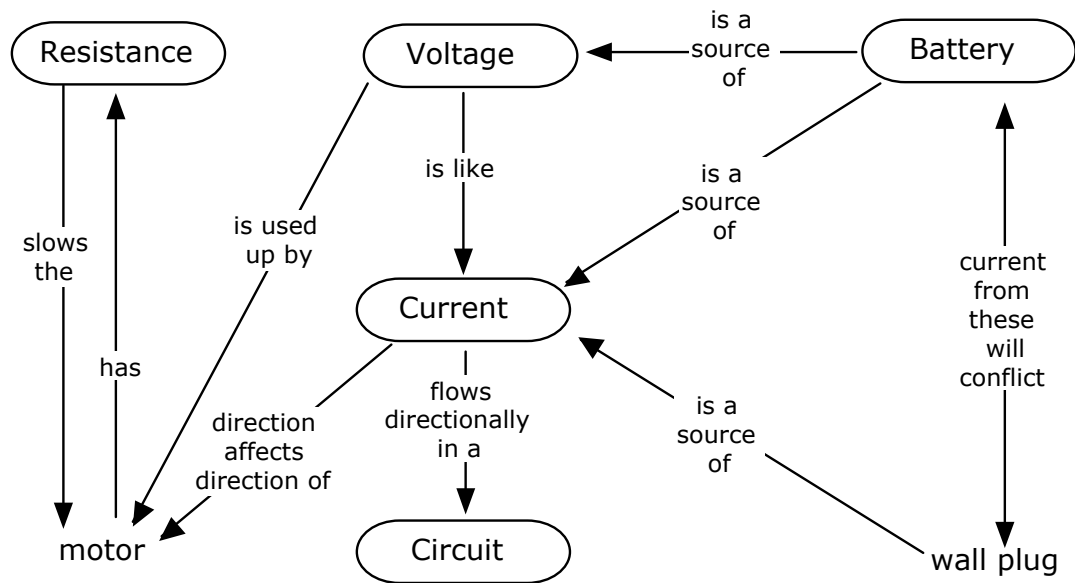

Figure 26: Concept map of JF, first observation

This was an introductory exercise into the relationships between current, voltage, and resistance. Students also had to think about which was the most accurate way to measure current. JF, on looking at the schematics, thought that the idea was to measure voltage to the motor with and without resistance, and expected the motor to slow down when the resistor was wired into the circuit. He did not figure in the internal resistance of the ammeter, which he measured just before. His alternate view of the activity's purpose left him confused when the lab sheet asked him to calculate the motor current, until his lab partner coached him:

JF: "But I don't know what the motor current is."

P: "Motor current? Well, you know the voltage. You know the resistance. You're good to go."

JF: "I don't know the voltage, though."

P: "You don't?"

JF: "That right there? [pointing to meter] That's my batteries. That's just —"

P: "No, it looks like it. Yeah, it's the voltage from the batteries."

Once coached, JF recognized that this was an Ohm's Law problem and carried out the required calculations. However, JF was showing a new concept of voltage in which voltage resembled current: that is, voltage was something that was used up by the motor. His expectation was that the measured voltage in the circuit should drop when the motor was running. Current, too, was expressed in terms of something that flowed. In the next exercise, students were to wire a circuit that used a switch to allow the wall plug to charge the batteries or the batteries to discharge. In both cases, the wheels of the robot turned. JF first believed that current from the wall plug and current from the battery would conflict with one another, like two streams of water colliding. The teaching assistant explained how this would work in terms of differences in voltage: that the wall plug had higher voltage, and that current would flow from higher to lower voltage, which made sense to JF and he proceeded with the exercise. He predicted that the direction of

the current would affect the direction of the motor, and found this was correct. He struggled to understand the difference between power generation and power dissipation in the exercise.

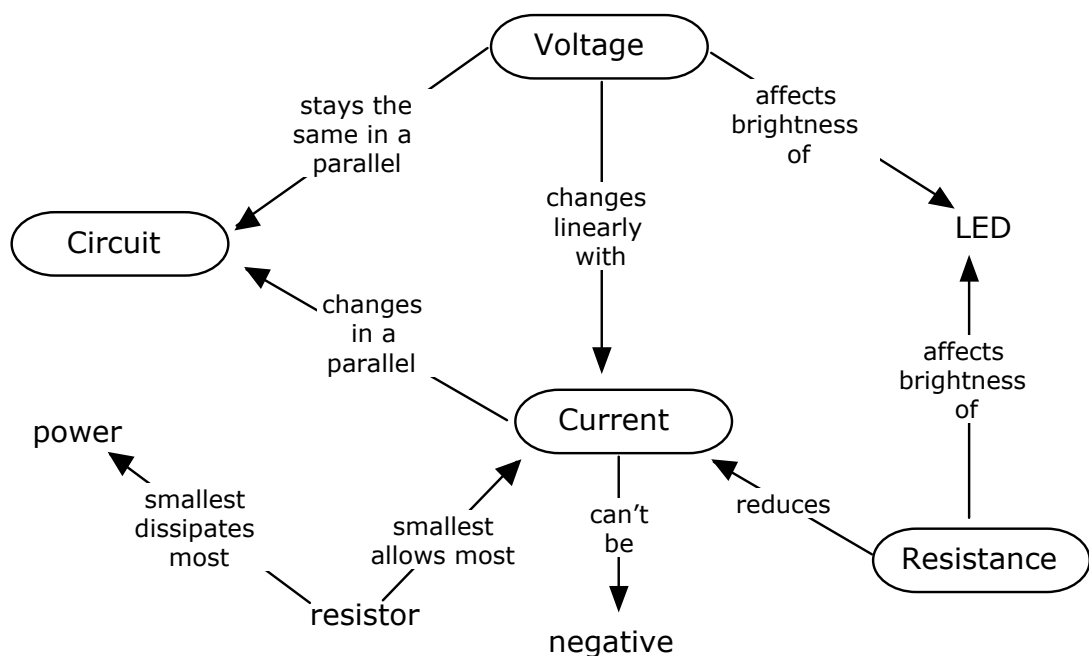

Figure 27: Concept map for JF, second observation

At the second observation (Figure 27), JF was beginning work on Lab 4, in which students were learning about the properties of transistors and diodes. While current was still central to his discussions about the circuits, by this lab JF was using the concept of voltage more in his conversations with his lab partner, though he still found it difficult to define. In the prior lab, during a session that was not videotaped, JF had completed an exercise in which he had measured voltage across and current through a set of resistors wired in parallel and in series. JF applied concepts he had learned in this exercise to the task at hand, and stated aloud to his partner that voltage would be the same across

resistors wired in parallel, but the current would change, that resistors dissipate power, and that the smallest resistors allowed the most current to flow. He knew that voltage, resistance, and current were related to one another, and that changes in voltage corresponded to changes in current and to resistance in many cases. This initially led him to predict that when measuring voltage and current across a diode as resistance was adjusted using a potentiometer, that voltage and current should both increase linearly. However, the transistor served as a switch, allowing no current through until the voltage reached a particular level, and JF's lab partner reminded him of this before they began the exercise. He predicted that changes in resistance and voltage should affect the brightness of the LED, until reminded again by his partner that the diode simply came on and there was little change in its brightness, unlike an incandescent bulb. JF spent some time turning the knob of the potentiometer up and down, observing the effects on the LED, until he developed an understanding that satisfied him. This demonstrated JF's preferred mode of learning: hands-on activity, observing the results, and then forming a concept. Briefly as JF was wiring the circuit and predicting the outcome, he declared that current could not be negative. This again was corrected by his lab partner, who helped tutor JF in the required concepts and mentored him in the class.

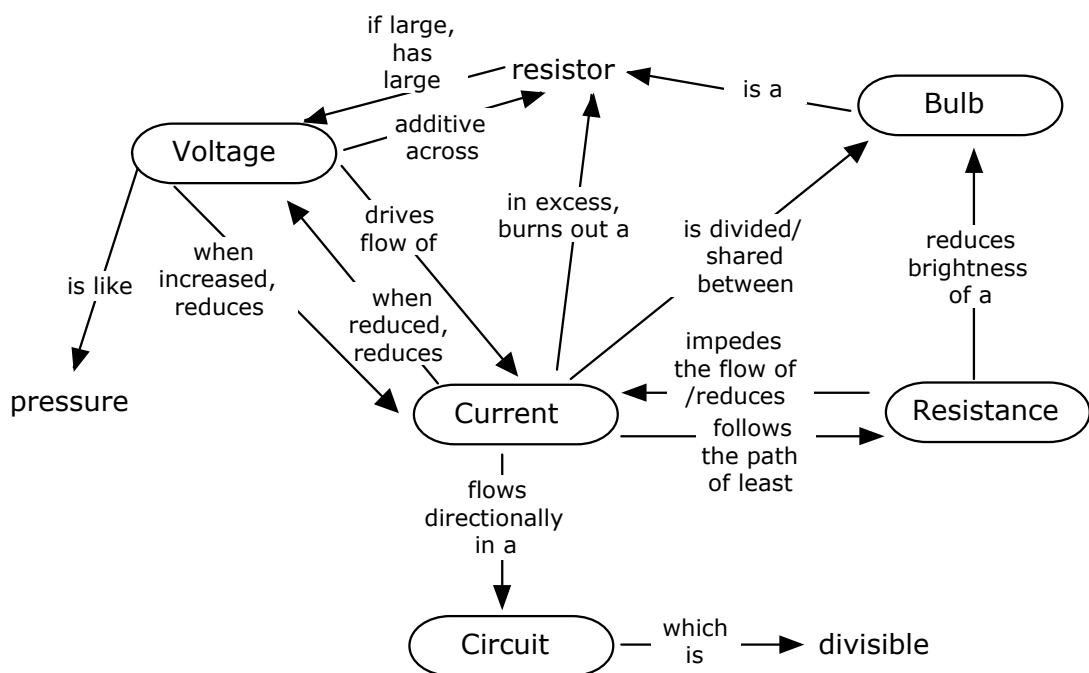

Figure 28: Concept map for JF, exit interview

By the final interview (Figure 28), JF's concept of voltage had grown more sophisticated. He recognized that voltage drives the flow of current, but pondered why high voltage, such as measured across a resistor, decreased current and when current was reduced, so was voltage. He used resistance in explaining why bulbs dim when wired in series, and again recognized that a bulb is a resistor. The influence of resistors, in his view, was additive in a circuit, and the voltages of a resistor were additive, at least in a series circuit. JF's views of current still had a material flavor, though the model was functional for him, as it allowed him to make correct predictions about the circuits that he wired during the interview. Resistance he now saw as something that impeded or reduced the flow of current, which he saw as something that flowed directionally in a circuit.

During the exit interview, JF expressed doubts about his choice of electrical engineering as a major, feeling that he hadn't been able to keep up with the course. His preferred mode of learning through direct experience was supported to some degree in the lab, but he found that to keep up with lecture, he needed to improve his math skills. He still had to pass college algebra before he could take the calculus series, which the other subjects were either enrolled in or had passed. He stated that he intended to take some more math classes in hopes that it would help him understand the engineering classes.

Table 16 summarizes JF's changing knowledge and meaningful knowledge across the term.

Table 16: *Summary of JF's knowledge about the target electrical concepts (circuits, voltage, current, resistance) across the term.*

Knowledge stated at the start	Meaningful knowledge: observation 1	Meaningful knowledge: observation 2	Knowledge stated at end
<ul style="list-style-type: none"> •current is electricity or power (terms used interchangeably) •current is quasi-material •current flows directionally in a circuit •current takes the path of least resistance. •resistance reduces current •voltage and current can be split by circuit elements, such as bulbs. •bulbs dissipate power •bulbs are resistors 	<p>From interview</p> <ul style="list-style-type: none"> •current flows directionally in a circuit <p>From other sources</p> <ul style="list-style-type: none"> •motor has resistance •resistance slows the motor •voltage is like current •voltage is used up by the motor •battery is a source of current •battery is a source of voltage •current from two sources may conflict. 	<p>From prior lab and interview</p> <ul style="list-style-type: none"> •resistors dissipate power •resistance reduces current (and thus smaller resistors allow more current) <p>From other sources</p> <ul style="list-style-type: none"> •voltage is equal across resistors in a parallel circuit •current changes across resistors in a parallel circuit •voltage changes with the current 	<ul style="list-style-type: none"> •voltage is like pressure •voltage drives the flow of current •when current is reduced, voltage is reduced •when voltage is increased, current is decreased •resistance reduces the flow of current •current takes the path of least resistance •current is divided or shared between circuit elements •bulbs are resistors

Subject AK

Subject AK came to the class with some background in electrical concepts from prior coursework in physics, including Advanced Placement Physics in high school. He had some background in electronics from building computers. The highest math level he had achieved was MTH 255, Vector Calculus.

During the initial interview (Figure 29), many of AK's ideas about electricity centered around moving electrons. AK used the term "push" to describe the action of voltage on electrons. The electrons, he believed, were contained in the battery, emitted from one pole, and attracted to the other. Current he described as the flow of electrons, while resistance was the constriction of the flow of electrons. He recognized the bulb as a resistor, and noted that flow of electrons through the bulb created heat and light.

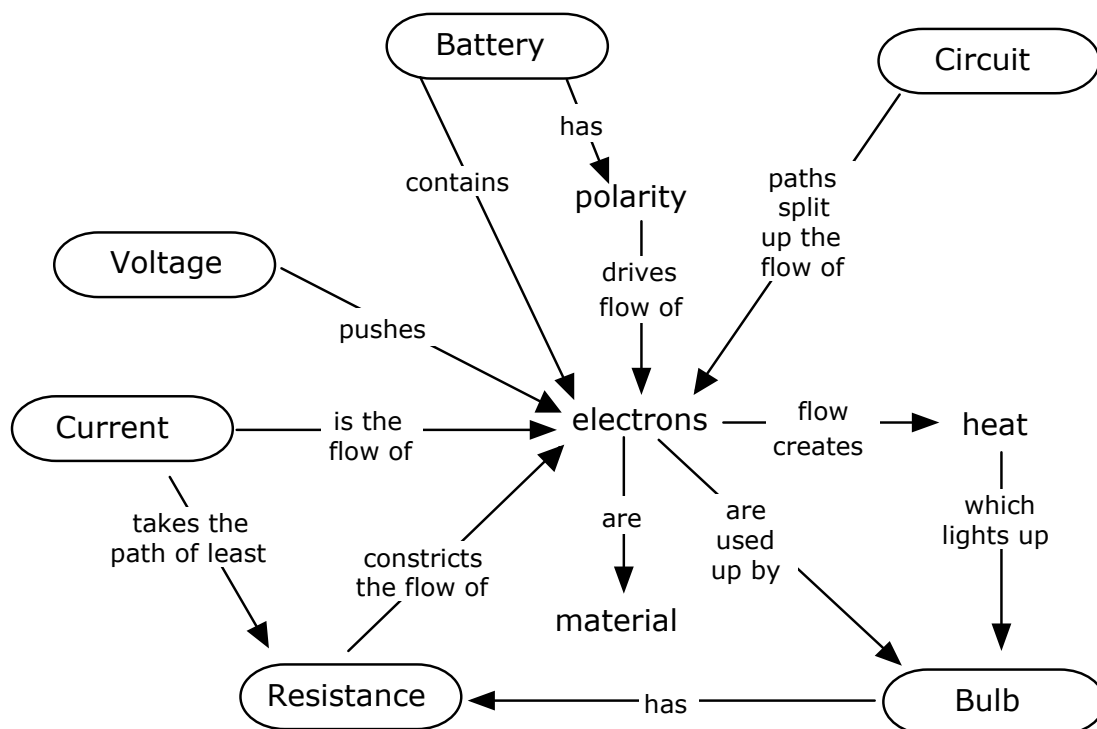

Figure 29: Concept map for AK, initial interview

His explanations were highly anthropomorphic, but he had been asked to explain electricity in simple terms, as though explaining it to a ten-year-old, so his anthropomorphizing was not taken literally. His view of electrons appeared to be material: he described them flowing in a stream, that the stream could be divided between branches of a circuit, and that the electrons were used up by the bulbs. The latter concept troubled him, because he could not reconcile the idea of electrons being used up with the idea that electrons must return to the battery to complete the circuit.

I: Okay, so why is that? Why are the two in series less bright than the single one?

AK: Ah — let's see — um, because — (long pause) the electrons are used up here and here (B and C). Um, wait. That doesn't quite make sense with my analogy of the electrons going through. Yeah, I'll stick with that. The electrons are used up here and here (B and C) instead of all here (A). So, um, that's why these are half as bright, or less bright.

I: Okay, so there's something flowing — let me make sure I've got this right — there's something flowing through here and you're saying that's electrons.

AK: Um, hm.

I: And they're being consumed by those?

AK: Um, they're being — let's see. Yeah. Yeah. I'll go with that. Half the electrons are being used by that one (C) and the other half are being used by that one (B).

I: Okay.

AK: Which doesn't quite make sense, because what goes back to here? (Pointing to battery) Um, but, ah, so — hm. See half of them are being used, and um, I don't know how they get back to here. They're being used to heat that up, but uh, and make it bright. And then they go through the circuit and through this one as well. Um, as to why they're dimmer than that one, let's — hm. Hm. Well. yeah.

I: So something about the idea of them getting used up isn't satisfying you?

AK: Oh, yeah. It's not. [laughs] But, I mean, they're going, running through that, but only half of them are — it's half as bright, because less electrons are going through there. I'm just trying to figure out why there would be less with two, instead of just the same amount going through — um, I mean, I could always just say less volts across, but that's just, like, a complicated term, volts. (AK, initial interview)

On the initial survey form, AK had written for Question 2, “same voltage drop” when explaining why any two bulbs should be the same brightness. He did not use voltage to explain the brightness until asked, and then explained that voltage was like pressure: it

pushed electrons around the circuit. What exactly voltage was did not seem to be clear in his mind; nevertheless, his concept of voltage as “push” and current a stream of particles, if not precisely scientifically correct, were nonetheless useful models that led him to correct predictions on the pre- and post-surveys. Prior experience in physics classes had shown him that two bulbs in series should be equally bright, and he knew to use the term “voltage drop” in connection with the phenomenon. Yet while he was not led astray by the idea that electrons should be used up by the bulbs, he had not yet found a way to use that model to explain his observations, and in fact found that the idea contradicted several of his other concepts around current.

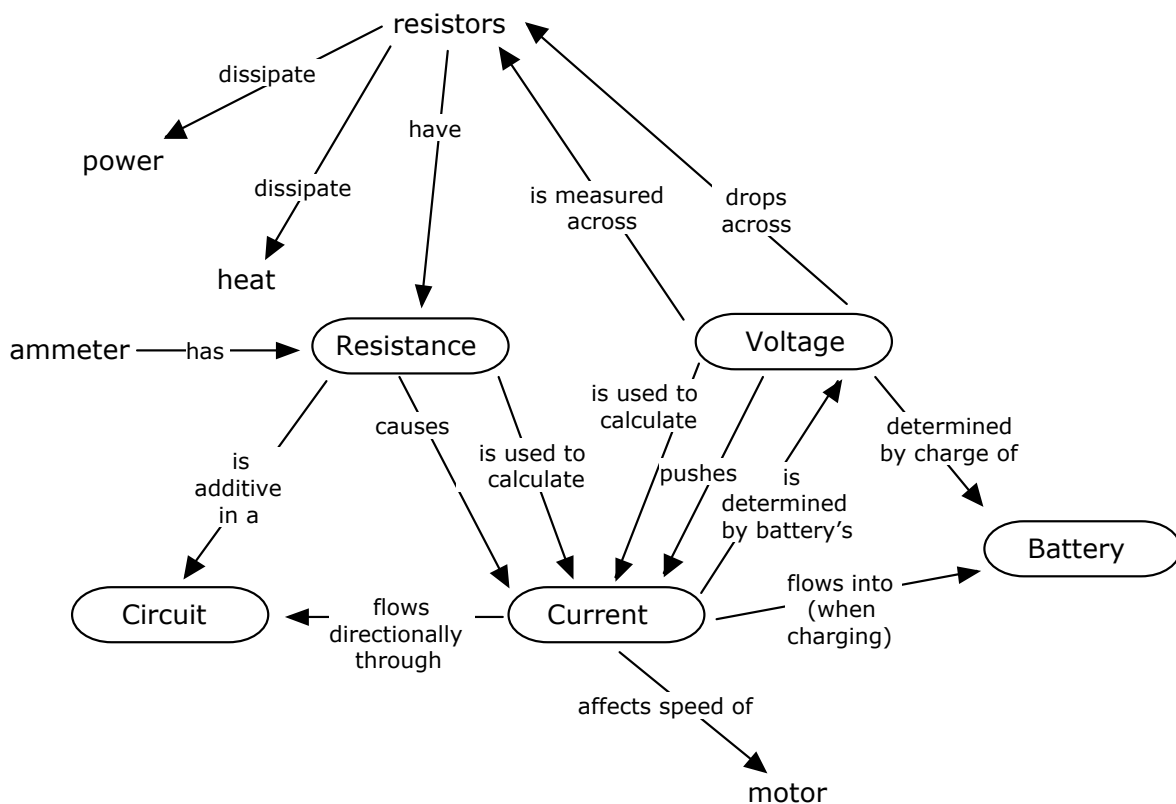

Figure 30: Concept map for AK, Observation 1

During the first observation (Figure 30), AK was working with subject MJ on the third lab. Most of their activities centered around a lab activity in which they arranged resistors in parallel and series, measured the voltage and current across them, and calculated the power dissipated. A great deal of their conversation centered around interpreting the schematics and building the circuits. As part of the exercise, they were to touch the resistors and feel the dissipation of heat, sensing directly how much energy each resistor dissipated relative to the others.

Much of the conversation centered around resistance, current, and voltage in relation to the lab exercises. Students were to use Ohm's Law and similar equations to understand the relationships between current, voltage, and resistance.

AK noted that resistors dissipated heat and power. Resistance itself he recognized as additive throughout a circuit: that is, any one resistor affected the performance of the entire circuit, and multiple resistors had a cumulative effect. Resistance he described as causing current to flow. The amount of current affected the speed of the motor: the more current, the faster the motor turned. Voltage supplied the "push" to make current flow, and current in a circuit was determined by the voltage of the battery. As a practical matter, he quickly learned that voltage must be measured across a resistor, as wiring the voltmeter in series as one would an ammeter could break the fuse.

A second observation was done on AK two weeks later (Figure 31), when he was working with Subject KR on the fourth lab exercise. In the exercise, the students were to measure voltage across and current through a diode that would act as a switch. AK had little trouble interpreting the schematic and building the circuit, and he stated explicitly

that current should be measured through the device, and current should be measured across. He explained the problem with breaking the fuse on the multimeter if it was wired incorrectly, and stated that a broken fuse would break the circuit, giving an incorrect reading. A broken circuit, in turn, would not allow current to flow, and thus the LED in the circuit would not light up. AK completed his circuit and was able to make the LED light up. He also stated that circuit elements with polarity, if installed incorrectly, could affect the measure of voltage in the circuit.

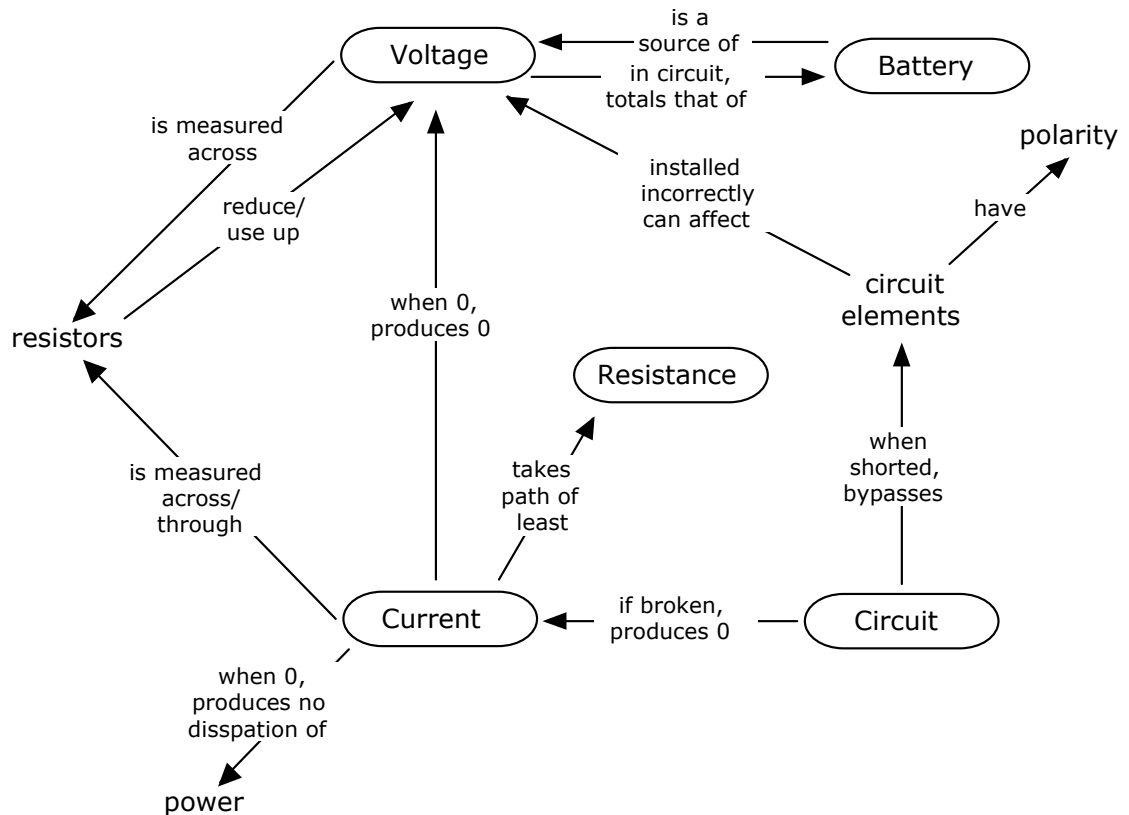

Figure 31: Concept map for AK, Observation 2

However, the purpose of the exercise was not just to make the LED light, but to use the diode as a switch. A potentiometer in the circuit acted as an adjustable resistor,

changing the voltage across and current through the diode. The LED remained unlit and current did not flow through the diode until the voltage reached a particular level, then the diode allowed current through and the LED lit.

The graph that AK produced showed voltage and current increasing linearly, rather than no current until a given voltage was reached. This was not corrected until the next class, when a teaching assistant asked to see AK's lab paper. It is probable that the circuit was wired incorrectly, perhaps bypassing the diode. This was a common error among other students who had not made the connection between a prior lecture on diodes and the lab exercise, so either did not have prior expectations regarding the outcome, or expected current and voltage to increase proportionally to one another.

In another instance, however, AK drew on the lecture topics to correct measurements that KR was obtaining. He knew that the voltage at that point of the exercise should be small, but KR had measured something larger than both of them expected. AK stated: "I'm getting .11. I thought it was supposed to be 0.2. Remember how they were supposed to work? 0.1 and 0.7? So 3 is huge." He suggested that perhaps the LED was installed backwards, stating that a polar component that was installed incorrectly could affect the measured voltage. At that point, AK was wondering why his own measure of voltage was 0, until he discovered that one wire that his multimeter was connected to had become disconnected with the circuit. "That might be why I was getting 0," he stated, noting that when the circuit was broken, there would be 0 current and 0 voltage. There was also a point of confusion when AK began to measure current across one of the resistors in a circuit, forgetting for the moment that current must be measured through. KR interrupted

him to point out that the multimeter would have to be wired in series in order to measure current. A teaching assistant came by and confirmed that current should be measured through the element. AK knew this piece of information in prior lab work, but the knowledge did not seem to be available at that moment.

AK's concept of voltage still involved the idea of "push," but another view became evident as he described voltage as being both reduced by and used up by resistors. AK appeared to be forming a new mental construct around voltage in which he saw voltage as being something like current. Here again his initial concept of current as something that was used up by circuit elements colored his thinking. He stated that the total voltage of the circuit should be that of the battery that was connected to it, and it is possible that the knowledge that batteries grew weaker over time led to the idea that some kind of electrical material in the battery was being consumed.

In the exit interview (Figure 32), AK's concepts around electricity centered more on voltage than on electrons and current flow. Here his concept of voltage as "push" was even more developed, but there was indication of a growing sense that voltage was something that flowed like current and was used up by circuit elements, and that batteries were the source not only of voltage, but of "push" supplied to the voltage to make it "go." AK saw voltage, however, as something supplying "push" to current, making it evident that his concept of voltage was still under development, composed as it was of fragments that he had not yet formed into a substantial model.

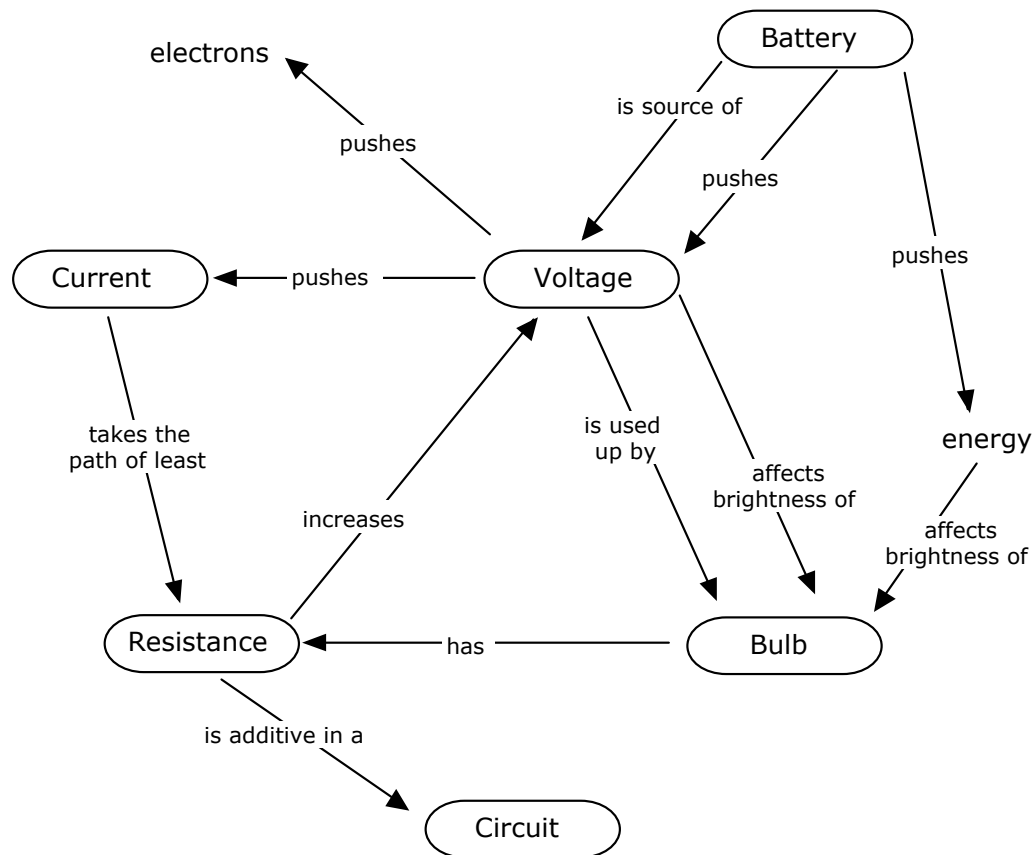

Figure 32: Concept map for AK, exit interview

The bulb he viewed as a resistor, a concept he had also demonstrated in lab. He also discussed the additivity of resistance in the circuit, noting that one resistor affected the entire circuit, a position he had started the term with. He connected resistance with an increase in voltage, which he had experienced directly with measuring voltage across various resistors in series.

Table 17 summarizes AK's changing knowledge and meaningful knowledge across the term.

Table 17: Summary of AK's knowledge about the target electrical concepts (circuits, voltage, current, resistance) across the term.

Knowledge stated at the start	Meaningful knowledge: observation 1	Meaningful knowledge: observation 2	Knowledge stated at end
<ul style="list-style-type: none"> •current is electron flow •battery contains electrons •polarity of battery drives electron flow •flow of electrons creates heat and light in the bulb •electrons are used up by the bulb •voltage is pressure •resistance constricts the flow of electrons •bulbs are resistors •current takes the path of least resistance •current is split between different paths of a circuit •current flow directionally 	<p>From interview</p> <ul style="list-style-type: none"> •polarity of battery drives current •current flows directionally <p>From other sources</p> <ul style="list-style-type: none"> •current is determined by voltage of battery •resistance must be present for there to be current •resistance is additive •resistors dissipate heat and power •current flows into a battery to charge it •voltage is measured across a resistor; current is measured through •speed of motor depends on amount of current 	<p>From prior lab and interview</p> <ul style="list-style-type: none"> •voltage is measured across a resistor; current is measured through •resistance is additive <p>From other sources</p> <ul style="list-style-type: none"> •broken fuse breaks a circuit, so current cannot flow •voltage is affected by resistance •no power is dissipated if the current is 0 •battery is the source of voltage •voltage is used up or reduced by resistors •when current is 0, there is no voltage 	<ul style="list-style-type: none"> •bulbs have resistance •voltage affects bulb brightness •greater resistance creates larger voltage drop which dims bulbs •voltage is used up by bulbs •voltage pushes current •voltage pushes electrons •voltage drives current •battery is a voltage source •battery can push volts •battery pushes energy •current takes the path of least resistance. •resistance is additive in a circuit. •if no voltage, then no current

Subject TA

Subject TA was a non-traditional student with prior experience in the U.S. Navy, where he had taken electronics courses for several months. Though it had been ten years since this experience, TA nevertheless arrived with strong knowledge about basic electrical concepts, as shown on the first survey. TA was also an electronics hobbyist, and indicated on his first survey form, “When devices stop performing as they should, I take them apart & try to understand how they work, such as a VCR, DVD player,

telephone, etc.” The highest math class he had taken was MTH 256, Applied Differential Equations.

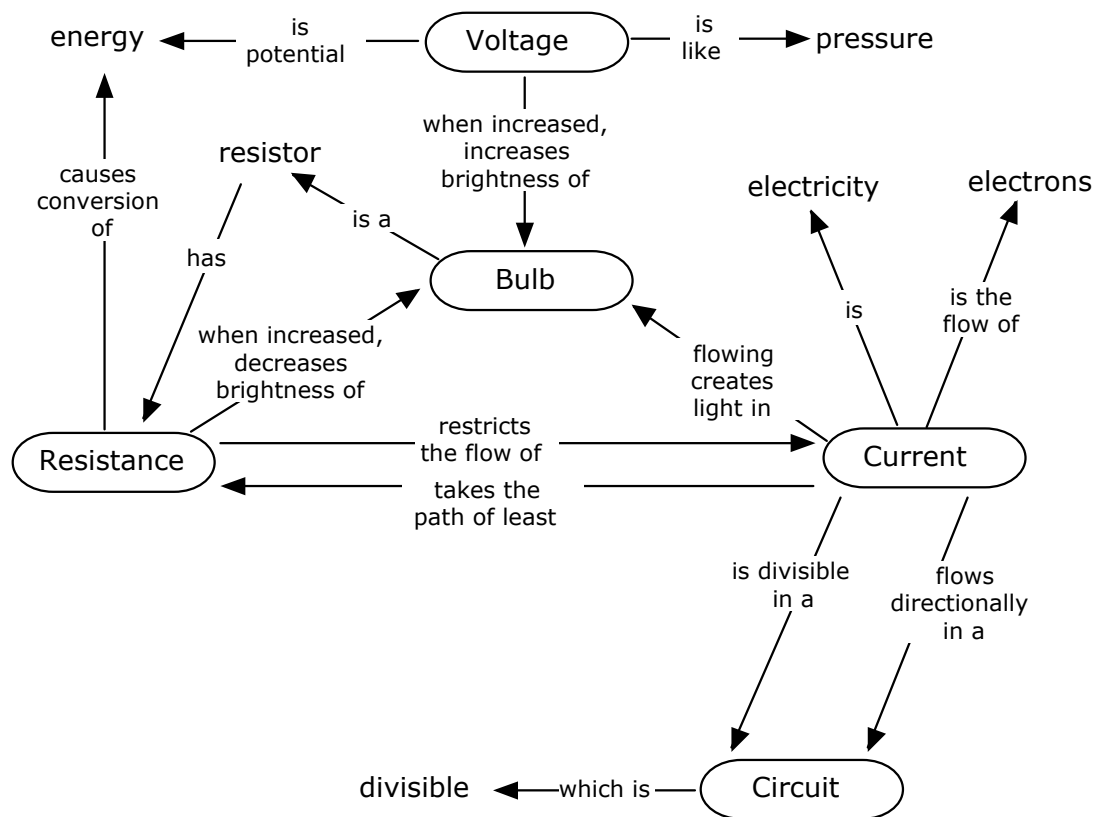

Figure 33: Concept map for TA, initial interview

During the initial interview (Figure 33), much of the discussion was about how voltage, resistance, and current all affect bulb brightness. TA was able to describe connections between the three concepts, though he expressed some doubt about his understanding of them, voltage in particular:

I: Okay. So what exactly is voltage? You're saying there's voltage around the battery. What exactly is it?

TA: Voltage —

I: How do you picture it working?

TA: Well, I guess voltage is, it's kind of potential energy. It's always measured at a reference. But I guess I don't have a really clear concept of, okay, this — wait, voltage is supposed to be, like if you compare it with water, like in a hose, the pressure. So— (laughs) so I don't know, I guess the change in pressure across here (pointing to lamp terminals) is the same as the change in pressure across here (pointing to other lamp terminals). (TA, initial interview)

Here TA was drawing on the water pressure metaphor used in lecture and on the lecture notes to help students understand voltage. He also understood voltage to be potential energy, though he did not quite understand how to employ the concept in his explanations.

TA stated that increasing the voltage in the circuit would increase bulb brightness, as would decreasing the resistance or increasing the current. Descriptions of what makes a bulb bright or dim were the center of his explanations of these concepts, and the primary tie between them. However, TA also described the effects of resistance on current, stating that resistance restricts the flow of current. Current itself he described both as the flow of electricity and the flow of electrons. Resistance he described as causing a conversion of energy, such as in the bulb where it converts electrical energy to light and heat.

Though TA struggled to recall vocabulary that he had forgotten, his basic understanding of these concepts was strong, and had a strong mathematical component, in that he was describing proportional relationships. Even though he could not describe what voltage *was* to his own satisfaction, he could describe what it *did*, often in abstract or mathematical terms:

I: Okay, then. Why are those two (B and C) the same, and then why are they less bright than this one (A)?

TA: Um, it's because they, they both are the same. They have the same current going through them, but obviously this circuit also has the same current, so it has to be due to the, um, voltage.

I: So what does voltage mean for you in that situation? Where is the voltage?

TA: We're going to have, like this is what? (pointing to battery) 3 volts total on the circuit here. So each one's going to have, the change in voltage is going to be one and a half volts across each one. Um, I guess it's because the voltage drop is equal and the way they're made up the resistance should be about equal. Um, the (laughs) all that's saying is the current's going to be the same, which I already said. (TA, initial interview, Question 2)

TA was observed in lab four times. The first lab he was working alone and finished assembling his robot early, then began work on an extra project. The conversations there were too scant to yield sufficient data for a concept map. In the fourth observation, TA and his lab partner were finishing the final lab in preparation for testing their “bump-bots,” and most of the conversation was around assembling the circuitry. During the second and third observations, however, TA was working with a lab partner who needed help with the activities, and the conversations uncovered a great deal of useful information about TA’s concepts.

Observation 2 (Figure 34) took place during the third lab, while TA and his lab partner were working with activities involving the passive sign convention and power dissipation in resistors.

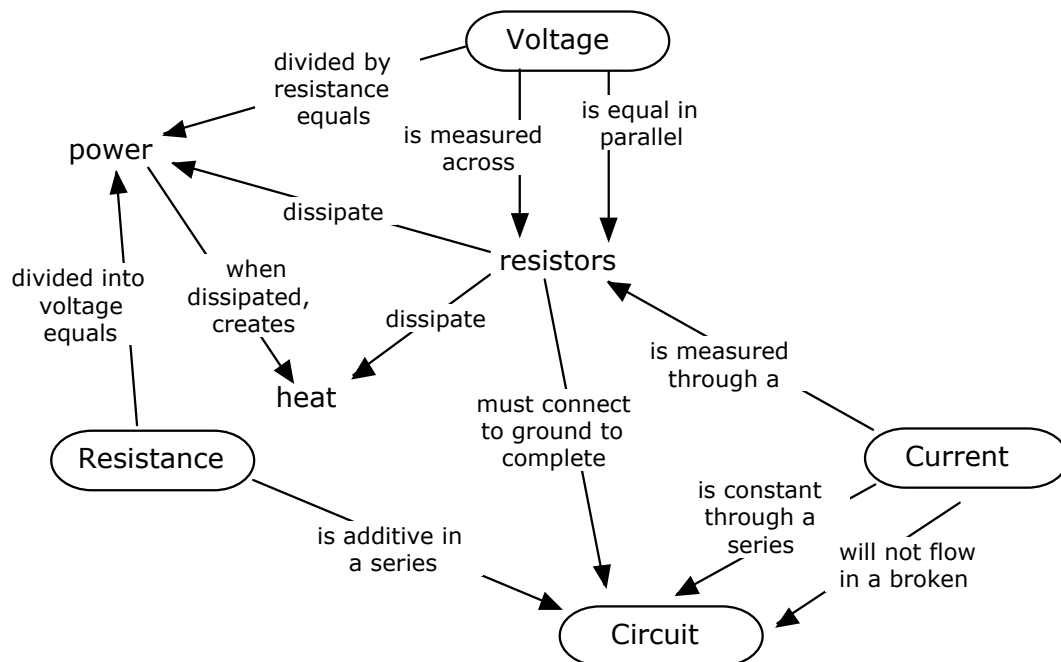

Figure 34: Concept map for TA, Observation 2

The explanations that TA used while conversing with his lab partner both related to the lab exercises themselves and reflected his mathematical and practical view of electrical concepts. TA measured voltage and current in order to calculate power dissipated, and used the results to frame his understanding of the circuits. For example, as part of the lab exercise, TA and his partner ran current through a single large resistor and found that it got very hot, then arranged several resistors in series that equaled in total the resistance of the large resistor. Even before applying current to the circuit, TA correctly predicted, “Because this was the overloaded resistor. I bet by using the same amount of resistance but spreading it over five resistors, that the power dissipated by each one will be within the range.”

As TA and his partner discussed the results, their conversation included statements regarding how resistors dissipate heat and power, and that the dissipation of power produces heat. TA also recalled from lecture that the voltage should be equal across resistors wired in parallel, and predicted this outcome before taking measurements.

TA’s statements were also around the practical aspects of working with electrical circuitry. He noted that voltage must be measured across resistors, while current is measured through. He noted that to complete the circuits the resistors must connect to ground on the protoboard, and that if the circuit was not complete, then current wouldn’t flow, noting, “If you don't complete to ground, you're going to have an open circuit.” While a linear model of electricity was rare among the students in the class, as shown on

the initial survey, not all students could successfully create a complete circuit on the protoboard without some instruction from the teaching assistants or lab partners.

During the third observation (Figure 35), TA and his partner were in the second week of Lab 4. They completed the required exercises to design a motor control board, and began an optional challenge project to create an amplifier. As in the prior lab, TA's partner had difficulty in creating a circuit, causing TA to note that without connecting back to ground, the circuit is incomplete and current will not flow. The circuit they were working with also included digital logic gates that controlled whether current flowed or not, and TA described how the completed circuit allowed current to reach the motor. Further, TA understood from the lab that the direction of current determined the direction in which the motor turned, allowing the robot to move forward or backwards.

TA noted that high resistance in the circuit through the motor controller effectively cut off current. He also stated that where there was 0 voltage, there would be no current. As in the prior lab, TA repeated his instructions to his partner to measure voltage across a resistor. He also noted that any one resistor in the circuit would affect the entire circuit, not simply those components that appeared to be "downstream," and that current takes the path of least resistance.

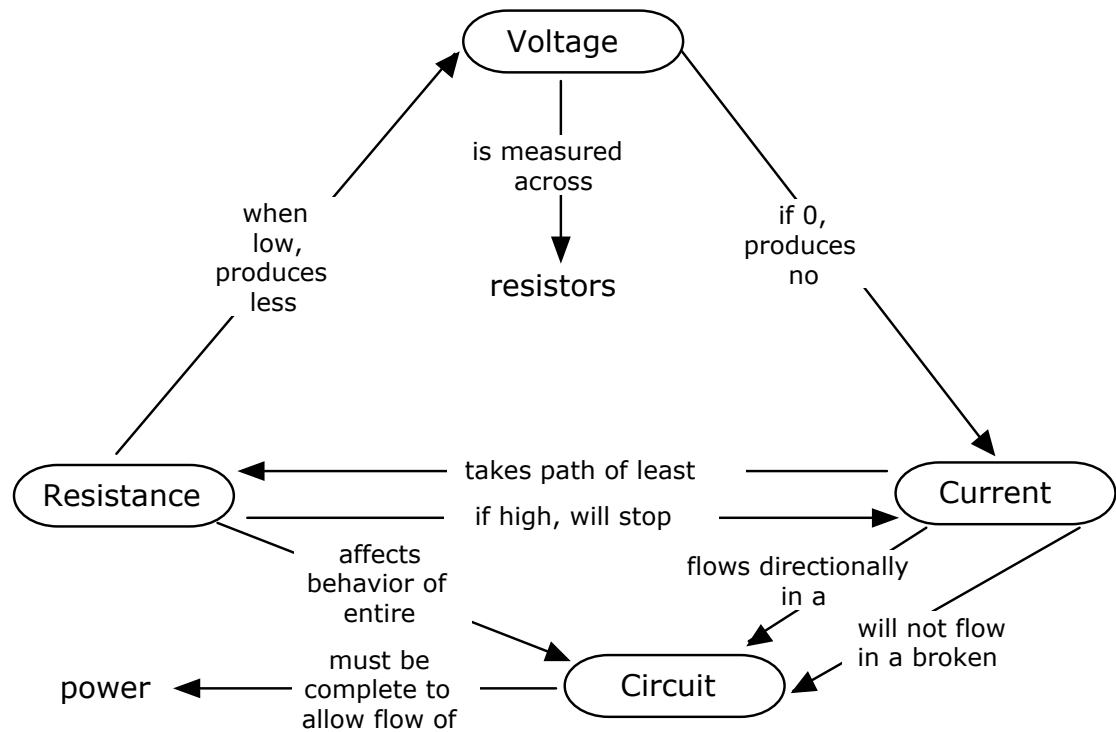

Figure 35: Concept map for TA, Observation 3

An interesting event occurred during this lab that illustrated a changing relationship between TA and his partner and may reveal one avenue by which TA achieved success in the lab. At one point, TA indicated a schematic in the lab, then handed the circuit board over to his lab partner and instructed his partner to build it. The lab partner asked if TA knew how to build it, and TA responded, “Yes, but I want to see if you can do it.” His partner did so as TA supervised. The relationship at that point had moved from equal lab partners to an instructor-protégé relationship, as TA had been taking the lead in the activities and giving instruction to his partner. By teaching aspects of the lab to his partner, TA may have been reinforcing his own knowledge as well as increasing his confidence in his knowledge.

Interestingly, the concept map for TA's exit interview (Figure 36) was initially simpler than that of the initial interview. The interview was shorter, and TA gave briefer explanations to each of the problems. While the outcomes of his lab assignments and conversations in lab revealed far more information, TA's responses during the exit interview were more focused than they had been in the initial interview, revealing only a portion of the knowledge needed to respond to, what may have seemed to him, simple problems. His written responses on the exit survey, however, were more complete than those of other subjects, and again reflected his mathematical approach to understanding electrical problems, which added further links to the concept map. For example, in response to 2d, which asked about the relative brightness of a single bulb vs. that of a bulb in a parallel circuit, TA predicted both would be equally bright, and wrote, "Given that the bulbs are made identically, they will have equal internal resistance. Given voltage V , and resistance R , the current through A will be V/R . The current through D will be V/R also."

His verbal response to the problem during the interview was similar:

Now that they're in parallel, um, you've got, well it's like two isolated circuits here. You've got one like — the voltage is the same across both of these, so you've got the full, your source voltage. The resistance in each of these loops is just the one, the light bulb's internal resistance, so it's identical to this, so since V equals I times R and it's the same as in this one, it's the same current. (TA, exit interview, Question 2)

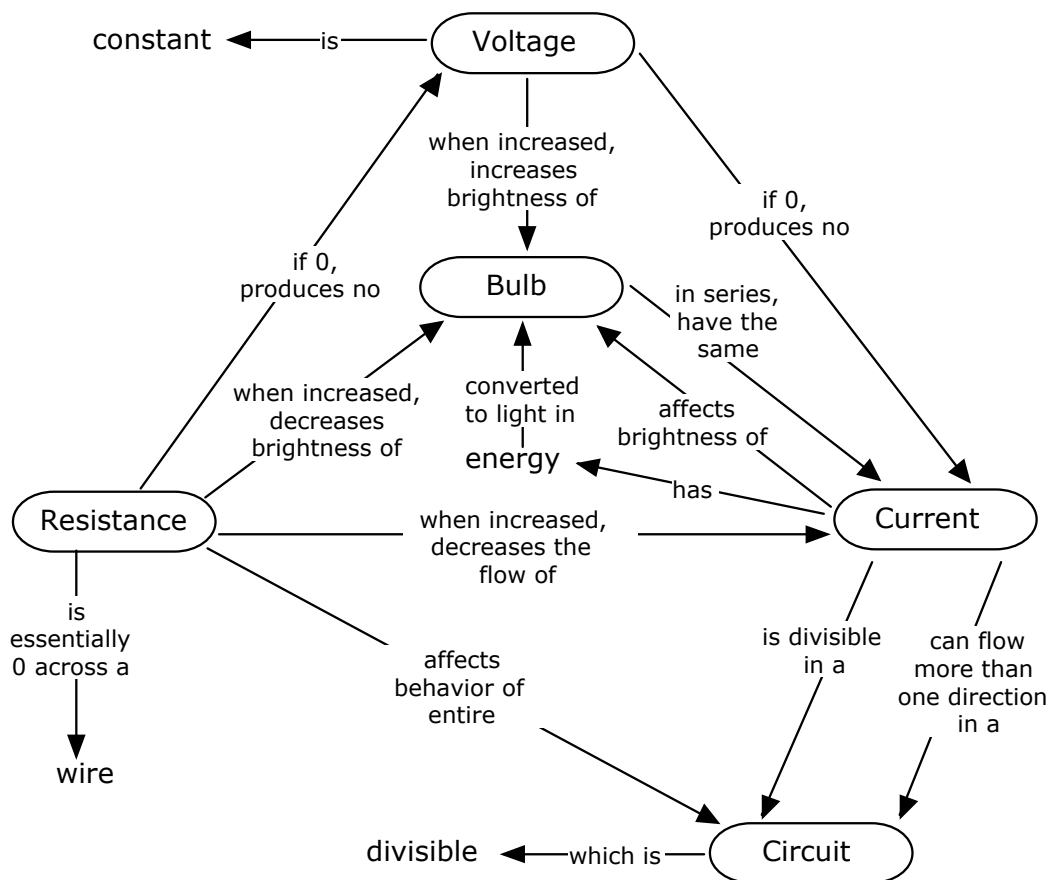

Figure 36: Concept map for TA, exit interview

His response to Question 3, in which two bulbs wired in parallel connect to single bulb, was also largely mathematical. TA predicted that bulb C would be brighter than A and B, and stated, “Since $I_T = I_A + I_B = I_C$, bulb C has twice the current and will be brighter than the other two.” His verbal response to the same question was less mathematical and more conceptual:

It’s got the full, um, current of this circuit. And these are parallel, you have, the full current is coming along through here, and then you’ve got a

current divider here. So it's being divided over these two. So they each have half the current, but then they're tied here, so then you have the full current that can go through C. (TA, exit interview, Question 3)

TA seemed comfortable with reasoning using resistance, voltage, current, and the relationships between all three. He did not seem to favor any one concept in his explanations, in contrast with those subjects who relied almost entirely on current in their initial interview, and some of whom moved to voltage as a preferred explanation in the exit interview. TA recognized the interrelatedness of all of these concepts and employed them all and the relationships between them in his explanations.

TA did run into difficulties explaining Problem 6, where two bulbs and two batteries were wired in series, but a switch was wired across the circuit in such a way that most subjects believed that it separated the circuit into two separate circuits. He gave the correct response on the survey, but in explaining his response, he first indicated the direction of current in the two circuits to flow in opposite directions across the switch. When asked what the voltage drop across the switch would be, TA stated it would be 0, but then noted that even so, current might flow across as it would across a wire that shorts a circuit. He could not, however, reconcile the idea that current could flow two directions at once, or clash across the switch, and decided that there would be no current across the switch.

Table 18 summarizes TA's changing knowledge and meaningful knowledge across the term.

Table 18: *Summary of TA's knowledge about the target electrical concepts (circuits, voltage, current, resistance) across the term.*

Knowledge stated at the start	Meaningful knowledge: observation 2	Meaningful knowledge: observation 3	Knowledge stated at end
<ul style="list-style-type: none"> •current is electron flow •current flowing through a bulb causes it to light. •Energy of current is converted to light energy •resistance restricts the flow of current •resistance created light and heat •bulbs are resistors •greater resistance reduces bulb brightness •voltage is potential energy •voltage is like a change in pressure •resistance affects the whole circuit •current takes the path of least resistance •current is divisible •circuit is divisible 	<p>From interview</p> <ul style="list-style-type: none"> •resistance affects the whole circuit <p>From other sources</p> <ul style="list-style-type: none"> •circuit must be complete to allow current to flow. •voltage is measured across a resistor •current is measured through a resistor •resistors dissipate heat •resistance is additive in series •current is constant in series •wire has 0 resistance •voltage is equal across resistors in parallel •resistors dissipate power •resistors dissipate heat 	<p>From prior lab and interview</p> <ul style="list-style-type: none"> •voltage is measured across a resistor •current is measured through a resistor •resistance affects the whole circuit •resistance is additive in series •circuit must be complete to allow current to flow •current takes the path of least resistance •resistance restricts the flow of current <p>From other sources</p> <ul style="list-style-type: none"> •where there is 0 voltage there is 0 current •current flows directionally •high resistance will stop current 	<ul style="list-style-type: none"> •high resistance reduces bulb brightness •same voltage in bulb produces same brightness •current is divisible •high resistance reduces current •if 0 resistance, then 0 voltage •resistance affects entire circuit •as resistance increases, current decreases •bulbs in series have the same current through them •bulbs in parallel have the same voltage across them •current has energy •a bulb lights when it converts electrical energy to light. •resistance of a wire is 0

Summary

A comparison of concept maps drawn for each observation suggests that body of knowledge expressed by each subject changed considerably with each changing context. All concepts of interest were expressed in the initial and final interviews, as subjects were questioned about these concepts during the interviews. Not all concepts came up during the labs, however, particularly concepts around the function of a bulb, since the labs did

not involve any incandescent bulbs. The exception was when JF predicted that an LED should dim or grow brighter when a potentiometer was adjusted. Here JF was drawing on his prior knowledge of incandescent bulbs, and expecting an LED to behave in a similar manner, which he learned by experience was not the case. Batteries were used in the labs, but students did not often talk about how the batteries themselves functioned, except to wonder, if a circuit was not working in the way they expected, whether the batteries were charged or not. Conversation during the labs centered around practical aspects, such as how to assemble the circuits from schematics. Subjects were also more concerned with the application of concepts to the lab than with the actual concepts themselves; that is, they were more likely to talk about what voltage *did* than what it *was*.

All subjects increased their knowledge over the course of the term, as was expected. The concept maps from the initial to the final interviews became more complex as subjects used more concepts in their explanations and reasoning. Even when subjects held alternative conceptions at the end of the term, their links between concepts had increased. In many instances, subjects were observed using concepts from lecture and applying them to lab, either remembering what the instructor had taught or referring to their notes to find something that related to the problem at hand. This was the expectation of the instructor and teaching assistants: that the students would apply knowledge learned in class to the lab tasks.

The lab tasks themselves were complex, and required that students remember multiple abstract concepts as well as a great deal of procedural knowledge and apply them simultaneously. The cognitive load that this created could be overwhelming at

times. Many students in lab worked in pairs in order to have someone else to consult with, or relied on the teaching assistants for help. Subjects were as likely to run into trouble by misremembering procedural knowledge, such as how to wire a multimeter to measure volts versus current, as they were by using alternative conceptions around the expected content knowledge. Mathematical ability emerged as a possible factor that might have affected student performance; subjects in this study were taking math classes ranging from basic algebra to advanced calculus, and showed varying levels of confidence with the calculations required in lab, though none of the calculations required mathematics beyond algebra. Data regarding mathematics level had not been collected at the start of the study. Instead, after observing how some subjects struggled more with both calculations and understanding, the researcher began asking the subjects about the math they were taking, and added a question about current math coursework to the final survey. While any conclusions drawn about the connections between math experience and student performance are highly tentative, they were interesting enough to document suggest further study may be needed.

Content knowledge did have an effect on student reasoning during performance of the lab tasks, as prior knowledge created a set of expectations that subjects had regarding the outcomes of the tasks. In many cases this was as simple as recognizing that a circuit that didn't work might not be a complete circuit, since current cannot flow if the current was complete. Both TA and AK made explicit comments about lack of current or voltage in an incomplete circuit. Current directionality was a concept that highly influenced subject expectations. For example, subject YZ had a highly directional concept of current, and

based on this, developed an expectation that the direction of the current affected the direction that the motor would turn, and thus alter the direction of the robot's wheels. His expectations were confirmed by his observations. The same concept of directionality in current and polarity in circuit components led MJ to always double-check her components before installing them, for fear of installing them backwards and causing something to malfunction. KR asked a teaching assistant which side of a resistor he should measure current on, expecting that there would be a difference on one side versus the other. YZ also had an expectation that where there was high resistance there should be low voltage due to his conceptual understanding of voltage as being something like current. This changed after he measured voltage across many different resistors, and was forced to rethink his ideas about voltage. TA's understanding of the additivity of resistance was expressed in the expectation that several resistors in series, with the same resistance as a single resistor, would dissipate as much power, but would not get as hot, because the dissipation was spread out over multiple resistors.

However, prior expectations, even when correct, could lead subject astray. MJ, AK, and KR all had an expectation that voltage and current should increase proportionally. During a lab exercise in which they measured voltage across and current through a diode, all three had somehow mis-wired the circuit and rather than creating a graph that showed the diode functioning as a switch, allowing current through only after voltage reached a certain level, their graphs showed a steady linear increase in both current and voltage, fitting their expectations, but not depicting the actual performance of the diode, which had been discussed in lecture. JF made the same prediction, but had wired the circuit

correctly and obtained the correct results. Both JF and KR, when looking at the schematics of the first exercise in Lab 3, in which they were to measure current through the robot motor directly, then measure voltage across a resistor in the circuit and use that to calculate current, observed one circuit with a small resistor and one without and predicted that the purpose of the exercise was to notice how the motor slowed down with the resistor in the circuit. This caused them both confusion as they tried to interpret the results and calculate current.

Subjects learned from their errors in lab, and this became part of their meaningful knowledge that they carried from one lab to the next. For example, YZ used a multimeter incorrectly when he was using it as a voltmeter but wired it into the circuit as he would have if it were an ammeter, and thus blew the fuse. In the subsequent lab, he repeated this bit of practical knowledge several times, careful not to make the same mistake again. KR, when shown how to correctly use the multimeter to measure current and voltage, self-corrected later when he nearly used the meter incorrectly, and repeated this knowledge several times in a later lab. However, comparison of the bodies of meaningful knowledge expressed by the subjects across the labs showed that their body of meaningful knowledge changed for each task not by growing larger as expected at the beginning of the study and suggested by Bransford et al.'s (1993) model, but by changing to fit the content of the lab and the subjects' interpretation of the lab.

Quality of Student Reasoning

Discerning the effects of student knowledge on their reasoning when seeking to describe model-based reasoning required an analysis of student prior knowledge, then looking for instances of that prior knowledge coming out in student remarks about the tasks, or demonstrated by student actions and choices. Without a complete running account of a student's entire train of thought, only a partial description is possible. However, student remarks and actions do give a revealing glimpse into the effects of knowledge on reasoning.

Subject AM

AM began the term with low prior knowledge (initial survey score: 6) and his explanations of current in the initial interview carried strongly material view with a view that current should flow in a particular direction, such that components "upstream" should only affect those that are "downstream."

In some instances, this material model proved useful in making predictions. In Lab 2, as AM was building the required circuits for the lab tasks, he observed that no current was flowing in one circuit and stated that there must be a break in the circuit. His explanation was that current will not flow in an open circuit. By tracing the expected path of current, AM and his partner were able to correct the circuit without help and produced a working circuit. Yet AM's reasoning in this instance was largely descriptive: he knew that current would not flow in an open circuit, and could describe flowing current, but could not explain it in terms of causative agents.

By the time AM began work on the Lab 2, he had developed an idea that resistance is additive; that is, the resistance in a series circuit equals the sum of all resistors in that circuit. This allowed him to correctly predict the outcome of a task involving the construction of a series of resistors. AM predicted that the resistance in the entire circuit would be similar to the resistance in a circuit that contained a single, large resistor. His concept of resistance as “holding back” a material flow of current was consistent with and supported by his observations: if one large resistor “holds back” a lot of current, a series of small resistors should “hold back” just as much current. Though his model lacked scientific accuracy, AM was reaching for a relation-based explanation based in causation.

AM noted several times during observations that voltage may be either positive or negative, and that installing a circuit component the wrong way will give an incorrect voltage reading, as well as possibly damaging the circuit. AM developed this idea from experience: he had in fact installed a diode backwards in his TekBot, and the diode heated to the point of smoking. However, though AM could make correct predictions based on this description of his observations, his explanations were incomplete. One partial explanation he offered was based in his model of directional current flow. If components are designed for current to flow through them one way, then current flowing the opposite way will somehow damage them. However, this again is more description than explanation. Without a strong idea of what voltage is, AM could not take the explanation any further.

AM's lack of a strong distinction between voltage and current led to confusion over how to measure voltage and current. AM had considerable difficulty in the second lab distinguishing between measuring voltage across a resistor and measuring current through a resistor. Partially this was a matter of understanding how to wire the multimeter correctly to obtain these measurements. Partially it was a lack of understanding that the multimeter becomes a part of the circuit that it is measuring. But a contributing factor to his confusion was his lack of distinction between voltage and current. If voltage is like current, as he initially thought, or if it is a measure of current, as he later thought, there was no logical reason why the two should be measured any differently. AM struggled to carry out the procedures correctly, but had no supporting mental model to help him remember how to measure each.

Subject YZ

YZ began the term with low knowledge of electrical concepts (initial survey score: 6). Like AM, YZ had an implicitly material view of current, in spite of stating that current was energy, and believed that current mixed with chemicals in a light bulb caused the bulb to emit light. YZ believed that current flowed directionally, and this expectation that the "stuff" of current should flow one way or another led YZ to correctly surmise that changing its direction would affect the direction in which the wheels turned on the TekBot.

YZ's biggest problem in the lab was translating from schematic to actual circuit, which was perhaps less an error of reasoning than of spatial understanding. He

understood the difference between parallel and series circuits on paper, but this understanding was not enough to allow him to build the circuits without help. His tendency was to wire everything in series, particularly during the first observation.

In the first observation, when YZ was working on Lab 2, he had difficulty in wiring the multimeter into circuit properly in order to measure voltage and current. Like AM, this related to his incomplete understanding of voltage and a failure to recognize that the meter becomes a circuit element. YZ confounded voltage and current, and consequently had difficulty remembering how to measure each. A stronger conceptual knowledge of what voltage is, as well as a better understanding of how the meter works, might have helped reinforce his memory.

During the lab, YZ expressed an expectation that a higher resistance should result in a lower measurement of voltage, because the resistor should “remove a portion of the voltage.” Though the surmise was incorrect, YZ was reaching for a causative explanation. If, as he assumed, voltage was like current, and resistance held back or removed current, then it should do the same for voltage.

By the second observation, YZ was able to recognize the difference between measuring voltage across and current through a resistor, partially through extensive coaching by the teaching assistant, and partly by hard experience after he burned out the fuse in his multimeter. As he worked with a partner on the third lab, YZ repeatedly stressed the importance of measuring the two properly. He could not form a coherent explanation as to why, but he could explain what would happen if one did not wire the circuit correctly. YZ also expressed correlational reasoning in his predictions as he

carried out the lab tasks. He predicted that where there was no current, there should be no voltage, and vice versa. He also predicted that voltage should be higher around larger resistors, a reverse of what he had predicted in the prior lab, showing a change in understanding due to experience.

Subject MJ

MJ began the term with low prior knowledge (initial survey score: 8), but a high mathematics ability. MJ described current as energy and as the flow of electrons in her initial interview. Her descriptions of current in her explanations of how circuits worked were implicitly material. She referred to current being “used up” by circuit elements, and described how the flow of electrons could be affected like resistance just like the flow of water is affected by a narrow hose. Her implicitly material view of current led to puzzlement about direction of current vs. direction of electron flow. She stated several times in the interviews and observations that she was confused about this issue, that it didn’t seem to make sense that something was flowing in both directions.

However, MJ also described current as energy, and noted that energy can be converted to other forms. Though her views carried a material implication, she was clearly trying to assimilate a scientific view. As she tried to understand voltage, she again reverted to the idea of water flowing: if current is like water, voltage is the pressure that moves it.

During the second lab, when working on series and parallel circuits with multiple resistors, MJ again referred back to the concept of voltage as pressure. Here the fluid

model served as a useful model to predict the outcome of each circuit. But in addition to a material, fluid model, MJ made frequent references to Ohm's Law, noting the mathematical relationships that existed between voltage. As she worked through the labs, MJ relied more and more on mathematical relationships than analogies. The mathematical relationships made more sense to her than trying to resolve the perceived conflict between the direction of electron flow and the direction of current flow. Thus MJ's reasoning was moving from analogic reasoning to use of abstract, theoretical models.

Before MJ's reasoning could be considered model-based, however, her use of Ohm's Law and other mathematical relationships used in the class, such as Kirchoff's Voltage Law and Kirchoff's Current Law, had to be thoroughly examined. Though Ohm's Law is a mathematical model describing the relationship between voltage, current, and resistance in a circuit, it is, of course, entirely possible that a student might memorize an equation such as Ohm's Law and use it routinely and automatically whenever voltage, current, or resistance are measured with no model-based understanding behind it. MJ's statements and actions in lab were analyzed to look for times when she used mathematical relationships in a routine way and when she used them as the basis for reasoning.

It was evident, for example, that in a lab exercise in which MJ, working with AK, built a circuit that included the TekBot motor and measured current directly and indirectly, that MJ was aware that this was an Ohm's Law problem. She and AK collected the measurements as instructed in the lab, filling in blanks in a table that

required the Internal Ammeter resistance, the motor current, voltage across the 1 ohm resistor, and the calculated motor current. Next to the table, MJ wrote:

$$V=IR$$

$$.1 = I(1)$$

$$I=.1A$$

$$=100 \text{ mA}$$

In several other places in the same lab, MJ wrote “ $V=IR$ ” and manipulated the equation as necessary for the current problem.

MJ, however, also incorporated mathematical laws into her reasoning and her perceptions of how circuits functioned. As such, she used equations such as Ohm’s Law as models and began her reasoning about a given circuit with the set of relationships described in these laws. For example, in the exit interview, MJ began an explanation about why the bulb in Problem 5 of the survey dims when resistance in the circuit is changed with these statements:

“...since $V=IR$, if you increase the resistance, then the current has to go down. And if you decrease the resistance, the current has to go up. So we increased the resistance and the current went down, so now there’s a dimmer light bulb.” (MJ, exit interview)

Thus MJ used Ohm's Law as a model to explain multiple phenomena. She used mathematical laws such as this to make predictions about circuits, and also used them as explanations of why bulbs, resistors, and other circuit elements performed as they did.

One place where this led her astray was when she was measuring voltage and current around a diode which acted as a switch. MJ expected a linear relationship between voltage and current, and because the circuit was mis-wired, observed what she expected and was satisfied with it.

Subject KR

Subject KR began the term with a relatively high level of knowledge (initial survey score: 14), and had some prior experience with electrical circuits through coursework and a summer workshop while he was in high school. In the initial interview, KR described current as the flow of electrons, using a pool-ball model that was used in lecture. This model was presented as a tube filled with pool balls. If one ball was pushed into one end of the tube, a ball would fall out of the other end. While KR described current as energy, he also talked about how current was used up by circuit elements. Thus in his thinking, current was a kind of fuel that was consumed, a view that implies a quasi-material quality. The concepts of current as a material-like fuel and current as something that flows emerged as KR was trying to understand a circuit in the first observation. In this exercise, students wired a circuit with a switch in such a way that when the switch was set in one position, current from a wall plug charged the batteries, and when the switch was moved, the batteries discharged. KR predicted that when the switch was moved, the

direction of current should also change, reasoning that if current were flowing into the batteries from the wall plug, then it should flow out of the batteries again in the reverse direction. In fact, the circuit was wired such that current as measured continued in the same direction.

As did other students, KR failed to consider the multimeter as part of a circuit when it was used to measure voltage and current. This, coupled with a hazy distinction between current and voltage, made it difficult for KR to distinguish between measuring across and through a resistor as he attempted to measure voltage and current. By the end of the first observation, KR had memorized how to measure voltage and current, but could not explain why they should be measured as he was shown. Here KR's reasoning was focused on the phenomenon, primarily due to lack of knowledge with which to reason about the phenomenon.

By the next observation, however, KR had added to his knowledge of and stated that when the meter was measuring amps, it had no resistance, whereas when it was measuring voltage it had essentially infinite resistance. This more fully developed understanding of the relationship allowed KR to view the meter as a circuit element, not a measuring device somehow separate from the circuit. Here KR was not simply generalizing based on empirical knowledge, but applying a model of the multimeter to the circuits in the exercise.

In the second observation, KR was employing a circular sequential model of the circuit, a model he only partially let go of by the end of the term. When preparing to measure current through a resistor during the second observation, KR consulted with the

teaching assistant to check his wiring, and stated the belief that measuring current “before” and “after” the resistor should produce different measurements. His sequential model led him to reason that current would be affected “downstream” of the resistor, and he wanted to know which side of the resistor he should take a measurement on. Yet in the same observation, KR noted that the voltage of the entire circuit should equal that of the batteries, indicating that in some instances he was able to apply a systemic understanding of the circuit. In both instances, however, his predictions were of a hypothetico-deductive nature, beginning with a general model and applying the model to the specific situation.

Subject JF

JF began the term with relatively strong knowledge of basic electrical concepts (initial survey score: 15). He had considerable direct experience of electrical circuits from his work in construction, which had given him an intuitive understanding of circuits that allowed him to make many correct predictions on the survey. JF’s understanding of the causes behind his predictions and observations, however, was weak. He could predict that the bulbs in a series circuit would be equally bright, but dimmer than a single bulb, because he had seen this effect before; he could not adequately explain why it happened. Nevertheless, JF’s intuitive models were useful.

JF’s views of current were implicitly material, and he generally used a circular sequential model of circuits. His prediction that a bulb “behind” a resistor would be brighter because the current would pool behind the resistor demonstrates both of these

views. Current, electricity, power, and electron flow were equivalent terms for the “stuff” that flowed through the wires. Voltage he had difficulty explaining.

JF’s quasi-material views of current came into play in his reasoning during the first observation. Noticing that the circuit he was building had both the wall plug and the batteries in it, he pointed this out to his lab partner and stated, “Wouldn’t these compete with each other if this [a diode] wasn’t here?” His expectation was that current emitted from both sources would clash in the wires. Later he noted the fuse in his multimeter and commented that the purpose of the fuse was to prevent too much current from getting into the circuit.

Current, for JF, was the primary force in the circuit. Resistance only slowed or held back current. The relationship between voltage and current still was unclear, and JF appeared to view voltage as something that flowed as well. As he built the circuits to measure voltage and current in a circuit which included the TekBot motor and batteries, JF strongly expected the voltage to diminish when a resistor was added, and was surprised when wiring the ammeter into the circuit to measure current and using the voltmeter to measure across a resistor produced similar effects on the motor.

Throughout this first exercise, JF was focused primarily on the immediate phenomena: the effects of adding or removing various resistors to the circuit. With coaching from his partner and the teaching assistant he was able to carry out the calculations involving Ohm’s Law, but did not step back from the activities and view them all as Ohm’s Law problems. JF’s discourse during the activities indicated that his focus was on following instructions, completing the circuits, and checking to see that the

circuits “worked.” In the second observation as well, JF’s attention was on carrying out the lab activities as directed and observing the resulting circuits to see if they “worked.” Generalizing to principles learned in class was difficult, and JF often asked for help from his partner and the teaching assistants to understand what the activity was about and how to carry out the calculations. In later conversations, JF noted that this, too, had been his focus when working on electrical circuits as a construction worker: wiring a given structure for a desired effect. While his final survey score showed excellent knowledge of electrical concepts, JF’s reasoning with these concepts did not progress significantly. Of all the subjects in this study, JF was in the lowest level math class. He noted in the final interview that a better understanding of math might have helped him understand and reason with the concepts learned in class.

Subject AK

AK began the term with a strong knowledge of electrical concepts (initial survey score: 20), and in the first interview, demonstrated well-developed models of electrical circuits which he used successfully to reason about and make predictions about the circuits presented in the interview. Much of AK’s discussion centered around electrons: current as electrons in motion, voltage as “push” or pressure applied to electrons, resistance as the restriction of the flow of electrons. There was an implicit use of current as material, though AK was not satisfied with this concept, as he thought it unlikely that electrons could be used up by the bulb in the circuit and yet flow back to the battery.

During the first observation, AK's model of voltage as "push" emerged as he predicted that a larger voltage from the wall plug would push current in the direction of the smaller voltage, the batteries. Current, he believed should flow into the battery to charge it. AK also used the relationships expressed in Ohm's Law to make predictions about voltage, current, and resistance in the circuits, making such statements as, "if you know voltage and current, you can calculate resistance." As with MJ, it was necessary to separate the routine use of Ohm's Law and other mathematical models as an equation into which a student might plug numbers, and use of the expressed relationships as a mental model of the way in which circuits function. AK used mathematical models in both ways, and in multiple instances expressed the relationships between voltage, current, and resistance as a functional and predictive model of the way in which circuits behave.

Voltage and current were distinct concepts that AK expressed, and he noted explicitly that the voltmeter should never be used to complete a circuit. He also noted that the multimeter itself had internal resistance which should be taken into account. However, in the second observation the material view manifested itself not in AK's concept of current, but of voltage, as he thought that a resistor would "use up" voltage.

Like MJ, AK's strongly mathematical understanding of the relationships between voltage, current, and resistance led him astray in the fourth lab, when he and his partner were assembling a circuit to measure voltage and current across a diode that was intended to act as a switch. Expecting voltage and current to change proportionately, AK was not surprised when the graph showed a linear relationship between the two, as this fit his model. However, the result should have been that no current passed through the diode

until the voltage reached a particular level. In spite of errors, however, AK demonstrated model-based thinking extensively throughout the observations.

Subject TA

TA began the term with a strong understanding of basic electrical concepts (initial survey score: 23). While TA was not confident in his ability to define voltage and current, he had a strong intuitive understanding of the relationships between voltage, current, and resistance, and approached the problems in the initial interview with a well-developed model of these mathematical relationships. TA stated, for example, that current would remain the same as it traveled through a series circuit, but different voltages in circuit elements, such as bulbs would result in different resistances, and therefore different brightness in the bulbs. With more bulbs, he predicted, there would be more resistance, and therefore the bulbs would be less bright. As with MJ and AK, TA did use mathematical models routinely, but also used them as a starting point for reasoning. It was evident very early in the study that TA used mathematical relationships between electrical phenomena as a mental model for predicting and explaining circuits.

During the second observation, as TA worked with and guided his lab partner, TA's model-based thinking emerged strongly. Much of the conversation revolved around resistors, as the primary exercise that TA was completing was wiring resistors in series and parallel. TA discussed the lab and made correct predictions for the outcomes by applying Ohm's Law before wiring and taking measurements for each circuit. He also correctly applied his non-sequential interrelational model of a circuit in predicting that a

series of resistors would have the same effect as a single resistor, but the heat dissipation across multiple resistors would not cause the overload noted in a single large resistor:

“No wonder they don't want us to do this very long, they're afraid we'll burn it up...

Because this was the overloaded resistor. I bet by using the same amount of resistance but spreading it over five resistors, that the power dissipated by each one will be within the range.”

Similar reasoning about resistance emerged in the next observation, where TA and his partner were working on a challenge problem. The circuit TA was designing involved using a transistor as a switch, and much of the conversation was around voltage, current, and resistance associated with the transistor. TA noted that high resistance in the transistor “stopped” current, and later that low voltage, and therefore low resistance, allowed current through. Several times he noted that the effects of resistance from any one element affected the entire circuit, demonstrating a non-sequential interrelational model of the circuit.

Table 19 summarizes the types of reasoning most often employed by the seven subjects.

Summary

The level of reasoning seen in the seven subjects varied considerably. While in general relation-based reasoning was seen in those subjects who entered the course with low knowledge and model-based reasoning was noted in those who came in with high knowledge, there were exceptions. JF, for example, began and ended the term using primarily phenomenon-based reasoning. MJ, who entered with low prior knowledge, quickly moved from relation-based reasoning to model-based reasoning.

While it had been expected at the beginning that subjects with high prior knowledge would show better reasoning skills, after the data were analyzed it became evident that prior knowledge alone was insufficient to explain the types of reasoning employed. However, when considering a third dimension, the level of mathematical experience in each of these subjects, a potential pattern of explanation emerged. JF was enrolled in Math 105, the lowest math class reported by any of the subjects, while MJ was enrolled in Math 256, the second term of second-year calculus, which was the highest math level reported by any of the subjects. Further evaluation of this relationship will be carried out in the Discussion section.

Table 19: *Summary of the reasoning employed by subjects during lab activities.*

Subject	Pre- survey score	Post-survey score	Reasoning: Nature of Explanation
AM	6	15	Phenomenon-based (explanation as description), to relation-based (empirical generalization)
YZ	6	11	Phenomenon-based (explanation as description), to relation-based (empirical generalization)
MJ	8	16	Relation-based (empirical generalization) to model-based (theoretical modeling)
KR	14	14	Relation-based (empirical generalization) to model-based (theoretical modeling)
JF	15	24	Phenomenon-based (explanation as description)
AK	20	21	Model-based (theoretical modeling)
TA	23	24	Model-based (theoretical modeling)

Chapter 5: Discussion and Limitations

Introduction

In this chapter, the findings in Chapter 4 will be discussed and connections drawn between student knowledge and use of knowledge during reasoning, and the current research literature on student knowledge and reasoning around electrical concepts. The discussion is organized around the guiding themes of the research. The model of task-based learning proposed in Chapter 1 will be examined in light of the findings, and the model modified to better describe student learning within this context.

Overall, student learning did increase during the term, and some of the knowledge gains that were documented related to the tasks that subjects worked on in lab. Subjects drew on their past knowledge and knowledge learned in lecture and lab to address new lab problems. The body of meaningful knowledge that was expressed during the lab tasks was highly situational, revolving around the task at hand, and had a highly practical aspect: students were more interested in how current, voltage, and resistance would affect the outcomes than what current, voltage, and resistance actually were. The body of meaningful knowledge changed for each lab activity according to how each subject interpreted the lab task and how much knowledge each subject could reason with at one time. Thus the body of meaningful knowledge that each student expressed was not a

single entity that grew in size; rather, it seemed to be a subset of a larger body of knowledge that was accessible to the students as they worked at the lab tasks.

Guiding and Emergent Themes

In this section, each of the three guiding themes of the research will be specifically addressed and emergent themes noted.

Phenomenological categories of knowledge

The concepts of interest in this study were current, voltage, and resistance, and the subjects' overall model of how circuits function. In addition, students expressed concepts around the functioning of batteries and bulbs that reflected their understanding of these components as well as their understanding of the concepts of interest. Their expressed knowledge was recorded and analyzed to develop phenomenological categories of knowledge: categories that described how students viewed circuit functions.

The concepts of current, voltage, and resistance were defined and taught in the first week of the term. After that, it appeared that students were expected to know and understand the concepts according to the target definitions that had been presented in the class notes. Many, but not all students, had taken ECE 111 in the fall before taking the current course, ECE 112, so would have had an introduction to these concepts. Yet it was evident from the initial surveys that a large number of students did not understand these basic concepts, and from the initial interviews with the seven subjects, it was clear that even after the first week of instruction, students held many alternate conceptions around

these concepts. At the end of the term, the survey and interviews showed that while some students were using the target concepts that had been taught, many others held various alternate conceptions, either the ones they'd held at the start of the term, or a different alternate conception that they had formed during the term.

The phenomenological categories defined for these undergraduate engineering majors closely resemble alternate conceptions defined in the literature on electrical concepts among elementary, secondary, and college-level students, suggesting that their ideas are widespread conceptions and not unique to this group of students. It would be reasonable, then, to predict that future classes might hold the same body of alternate conceptions and in response create assessment tools and methods of instruction to directly address these common categories of knowledge.

The phenomenological categories of knowledge uncovered in this study were as follows:

Batteries

Three categories of knowledge around the function of batteries were defined:

- Battery is a repository of current
- Battery is a voltage source
- Battery supplies voltage which causes current

“Battery as a repository of current” was a commonly held view by subjects at the beginning who expressed the battery function in terms of supplying current or energy to the circuit. In conversations about recharging batteries, it became evident that subjects

were under the impression that something went into the battery, filling it up, and that this “something” then circulated around the circuit and was used up by the components of the circuit. This understanding implies a material view of this “something,” be it current or voltage.

The model is a logical conclusion from common experience with batteries: a battery, connected to an electronic device, gets “used up” after a time and must be recharged or replaced. This also corresponds to Watts’ (1983) depository model of energy, in which energy is deposited in a battery and used by a bulb, which “needs” it. Cohen, Eylon, and Ganiel (1983) also found that high school students thought of current as a material substance that was stored in the battery and then supplied to a circuit. Pardhan and Bano (2000) uncovered the same model in physics teachers who thought that the battery stored up electrons and delivered them to the circuit, which used up electrons over time.

Through instruction and practice, several of the subjects moved from a depository model to a voltage model, in which the battery supplies voltage. Students who thought of voltage as something material that filled the battery was depleted were judged as having a depository model. The major indication that students had abandoned a depository model was that they saw the battery as creating voltage rather than expelling “voltage.” Nevertheless, students with this model did not always know why the battery supplied voltage. They recognized that the batteries in their robots were rated at a particular voltage. The voltage of the battery figured into many of their calculations in lab. It is probable that subjects made this transition because they measured voltage from the battery and discussed it the batteries and the wall plug as voltage sources rather than

current sources in the lab and lecture. So long as students held a vague notion of what voltage was, their knowledge remained in this category. When they formed a mental connection between voltage and current, they were able to state that the voltage of the battery was the causative factor behind current.

Bulbs

Two categories of knowledge around the function of light bulbs were uncovered:

- Light is the result of a chemical reaction between electricity and chemicals in the bulb.
- Light is the result of a conversion of electrical energy to light (and heat) energy. Bulb is a resistor.

While the first category may be describing knowledge created at the moment during the interview, the idea of light as an interaction between electricity and something in the bulb relates to Watts' (1983) "energy as ingredient" model, in which energy (including electricity) is seen as a substance that is necessary to mix with other substances and cause a reaction. Most subjects, however, entered the course with an understanding that the production of light is the result of a conversion of energy in the bulb. Most were also able to describe the bulb as a resistor, and by the end of the term they had directly experienced energy conversion and power dissipation in resistors and were able to provide explanations that tied together energy, dissipation, and resistance.

Current

Two categories of knowledge around the concept of current were described:

- Current is material or quasi-material; thus current can be “held back” or can “pool behind” resistors.
- Current is energy or power

A material view of current emerged as a critical factor influencing student understanding of other electrical concepts, their models of circuits, and their reasoning about electrical circuits. So long as they believed current was some kind of “stuff” that flowed through the wires, students had difficulty assimilating other target concepts in the course.

Many studies on electrical concepts in students have described student concepts of current. Current is the primary concept taught in elementary and secondary physical science electrical units, and most students view current as the primary factor in describing how circuits work. The subjects in this study were no exception. All of them in the initial interview used current or electron flow as their means of describing how circuits worked, and only through instruction and lab experience did they use voltage and resistance as critical factors in their explanations.

The subjects, like students in other studies, were unclear about just what current was, and used terms such as “current,” “electricity,” “energy,” “power,” and “force” interchangeably (Watts & Gilbert, 1983; Shipstone, 1985; Trumper, et. al., 2000). All subjects could describe current as the flow of electrons. However, this did not prove to be a useful descriptive category of knowledge by itself, since students seemed to have

different ideas about what exactly that meant. Their understanding of the nature of electrons appeared to be important, and should be explored further in studies of student concepts around current.

Many of their explanations implied, consciously or unconsciously, that current was a material substance or was the flow of a material substance. Hence though they used electron flow in their explanations, students seemed to think in terms of electrons as material particles moving like molecules of water in a hose, rather than thinking in terms of charges.

The hose analogy is widespread, used almost universally in textbooks to explain how current and voltage work. This often leads students to a model that Watts (1983) describes as a flow-transfer model, in which energy, including electricity, is seen as a kind of liquid. The model is strongly supported by the language of textbooks that talk about current flowing, having a source and a sink, being transported, conducted, the battery being drained, etc. Watts also described an “ingredients” model, in which the substance, energy, is used up by elements of a circuit. Trumper (1989) noted the same “energy as material” models in preservice teachers, and Osborne (1981) found the model in young children who believed that electricity could “leak” out of bare wires. The flow-transfer model is highly predictive, in that students can use it to correctly predict the outcomes of simple circuits, which is one reason it is so widely taught: it is a useful metaphor that helps students grasp relationships between basic electrical concepts. However, as a model for teaching future electrical engineers, it may actually limit some

areas of understanding that become important as students advance through their coursework.

Shipstone (1985) notes that electrical engineers that were interviewed in a study found the electron flow model to be too confusing to describe current in complex circuits. Their preferred model was “a field-like phenomenon, formed of endless loops.” Two of the subjects, MJ and TA, let go of the idea of current or electrons flowing and described events in circuits in terms of mathematical relationships between current, voltage, and resistance. For them this was a necessary step to work successfully with complex circuits, as it eliminated the apparent contradiction between the direction that current was depicted as moving and the direction in which electrons were shown, in the lectures, to move. The utility of the fluid-transfer model for electrical engineering students should be explored further to determine if it is a useful model or if it actually interferes with understanding at an advanced level.

Voltage

Five categories of knowledge around the concept of voltage were described:

- No concept
- Voltage is current or is like current; voltage flows or moves
- Voltage is a measure of the strength, size, or force of current.
- Voltage is pressure or push, which moves electrons.
- Voltage is potential energy.

Psillos and Koumaras (1988) and Shipstone (1984; 1985) note that in most school curricula involving electricity, current is introduced first as a primary concept, using the fluid model of electricity. Voltage is introduced later in relation to current. Because the current flow model is highly concrete, learners tend to remember it better and forget what they have learned about voltage, which is often presented as an abstract concept. In the interviews with the seven subjects, two had no concept at all of voltage, while others described it as potential energy, but did not know what it did. Only after instruction did they describe voltage as potential energy that drives current. One student, AK, entered the course with a concept of voltage as “push” that moved electrons, and retained this model throughout the term. It served as a functional model that helped AK solve problems involving voltage.

Even after exposure to voltage concepts in lab and lecture, and after measuring voltage frequently, several of the subjects ended the term with alternative conceptions about voltage, such as voltage as a type of current, or voltage as a measure of current. These findings align with Shipstone (1984; 1985), who found that most students often confused voltage and current, or thought that voltage was a measure of current. They also viewed voltage as something “extra” and not as important as current, or thought that current caused voltage.

Perhaps the same view is held among researchers investigating student concepts around electricity; far fewer research papers were found that included voltage as a concept as there were investigations of current, circuits, and electricity. One useful avenue of study might be to develop curricular units for physical science, physics, and

electrical courses that introduce voltage as a primary concept to discover if this is a more fruitful approach to instruction than a current-first approach, as suggested by Härtel (1985) and Psillos & Koumaras (1988);

Resistance

Three categories of knowledge about resistance were described:

- Resistance is holding back current
- Resistance is a restriction of current flow
- Resistance is the dissipation of energy

The subjects' concepts of resistance are related to their concepts of current. Subjects with a material view saw current as a fluid that could be held back by physical barriers or various forces, or could be restricted, like water flowing through a narrow pipe. Subjects who developed a more energy-related concept of current were more likely to discuss resistance in terms of dissipation of energy, though students with an energetic view also used the idea of restriction. The term was used in the fluid model of current, and students were shown diagrams of narrowing pipes, a concrete model that tended to stay with them. Dissipation was experienced in lab as students touched resistors to see how hot they became, and then calculated the power dissipated. It was surprising that this concept, though experienced in a concrete way, was not used more in the final interviews.

Resistance is another electrical concept that has received little attention from researchers. Pardhan and Bano (2001), when interviewing physics teachers, found that many teachers thought that resistance meant that electrons were being slowed down or

that some opposing force had been applied in the opposite direction. The class notes that the subjects read contained a kinetic molecular model of resistance in which electrons were described as flowing through the substance of the resistor and colliding with atoms, with subsequent loss of energy. While this provides a scientific explanation, students might draw conclusions similar to those in the Pardhan and Bano study.

Models of circuits

Four models of circuits were uncovered among the seven subjects in this study:

- Linear model
- Circular, sequential model
- Transitional model
- Non-sequential Interrelational model

The linear model, equivalent to Osborne's (1981) unipolar model, appeared only briefly in one student, MJ, who was not satisfied with the model and tried it out at home, quickly discovering that it didn't work. In the entire class, only one other person drew a unipolar model on the initial survey, suggesting that by the time they reach college, most students have rejected the linear model for a circular model.

Osborne and Freyberg (1985) describe a model that did not appear in this study: the clashing currents model. In this model, students believe that two wires are required to light a bulb with a battery because current comes out of both ends of the battery and meets in the bulb, making it light. A variation on this is an essentially linear, or unipolar, model in which it is acknowledged that the second wire is necessary, but it's only there as

some sort of safety feature. All subjects in this study who described loop-shaped circuits indicated current flowing in one direction.

A circular model, however, was not necessarily a scientific model. Several subjects held a circular sequential model, in which current flows in one particular direction around the circuit, and affects circuit elements differently depending on their order. Subjects may believe that the current is “used up” by one element, leaving less for the next, and thus the first bulb in a series would be brighter than the second. This corresponds to the attenuation model described to Osborne and Freyberg (1985). Dupin and Johsua (1987) found this model to be highly persistent. It was strongest in elementary students, and about one-third of college students in their study held this model.

Some subjects were explicit about the attenuation aspect, stating that one bulb would use up more electricity than the other. However, subjects also expressed a sequential model that did not include attenuation, and it was often difficult to decide whether the sequential model used by the subject included attenuation or not. For example, several subjects predicted that a resistor wired in series “before” a bulb would cause the bulb to dim, but one “after” the bulb would have no effect. There was no implication, however, that either resistor was “using up” current. The circular sequential model may need to be divided into sub categories of attenuation and no attenuation, but further study would be needed with careful attention to student ideas about what happens to current in the circuit.

By the end of the term, subjects had either developed a non-sequential interrelational view of circuits, in which each component affected the whole, or were in a transitional state, where they used an interrelational model for some problems on the interview but a

sequential model for others, or began with a holistic view but fell back on a sequential view when pressed for an explanation. When beginning with a sequential view, further questioning could lead a student to recall knowledge learned in class and set the sequential model aside for a non-sequential interrelational model.

Branching circuits

Three categories of explanations were described around the branching circuit problem on the survey:

- Brightness should change because one bulb gets both batteries and the other does not.
- Brightness should not change because the switch creates two separate, independent circuits.
- Brightness should not change because there is essentially no current across the switch.

The most common mode of explanation was to see the switch across the circuit as a divider that split the circuit into two independent circuits. Subjects did not consider the problem of clashing currents across the switch until it was pointed out to them. The conflict that this created led to either confusion and no further explanation, or a conclusion that current would not flow across the switch at all. The strong view that the separate loops of the circuit were separate circuits themselves deserves more study, since the subjects worked extensively with branching circuits in class, and had to design complex circuits for the final “bump-bot” project.

Shipstone (1984) notes that when studying complex circuits, the attenuation model remains a strong model. Students tend to analyze circuits in terms of separate components in sequence, and expect the sequence to matter. This fragmented view of circuits may help explain why subjects had a strong tendency to see the circuit as divided. Schauble, Glaser, Raghavan, and Reiner (1991) in a study described earlier used “black box” components to have student create circuits, then try to determine, by its effects, the identity of each of the “black box” components. From this study, the authors developed four levels of explanations about circuits. In Level 1, a simple local model, subjects described how each component worked or did not work. In Level 2, a main and additive model, subject described some components as “working” and some as “helping.” In Level 3, additive plus negation, subjects recognized that some components worked when they increased bulb brightness, and others worked when they decreased bulb brightness (whereas students in Levels 1 and 2 saw the latter as “not working”). In Level 4, causal system, subjects recognized that any outcome depends on the interaction of all circuit components. Experience and instruction are necessary to raise student thinking to Level 4, which is comparable to the whole systems model described in this study. The Schauble, et al. model deserves more attention in its relation to the models described in this study and in Osborne and Freyberg (1985) to create a more comprehensive description of student views of the behavior of components in complex circuits.

Factors related to student reasoning

As noted in the Results section, and summarized in Table 19, there was some relationship between level of knowledge and the type of reasoning employed by the subjects as they carried out the lab tasks. However, the dimension of mathematical experience emerged late in the study and provided what might be a stronger explanation.

It must be noted that mathematical experience was not a factor the researcher thought to pursue at the beginning of the study. During the course of the observations, however, several of the subjects commented on the difficulty of the mathematics that were used in the labs and even more so in the lecture, where the instructor often put a difficult problem on the overhead and had students work in groups to solve it. This led the researcher to ask the subjects what mathematics courses they were taking, and a question about mathematics courses was added to the final survey to further document the level of mathematics coursework students were enrolled in. The only data collected in regards to mathematics were the course numbers of the classes in which the students were currently enrolled, or had been most recently enrolled if they were not taking a math course that term. The university catalog supplied the name of each course, a general description of the topics covered, and where each course was in the hierarchy of mathematical coursework. There was no attempt during this study to document the actual content of the mathematics courses, nor to find correlations between the mathematics course content and the mathematical problems encountered in ECE 112. This would be fruitful grounds for future research.

Table 20 shows the relationship between level of mathematical coursework as reported by the subjects, electrical knowledge, and reasoning among the seven subjects.

JF, who came in with high prior knowledge, gained his knowledge in hands-on situations encountered in the construction business and did not have a strong grasp of mathematical relationships between concepts. JF was strongly aware that his lower mathematics experience put him at a disadvantage. He was not yet enrolled in calculus, and in the final interview, noted that he thought needed to take more math in order to better understand what was going on in the electrical engineering courses.

AM and YZ, who came in with low prior knowledge, were in their first year of calculus and were able to move from phenomenon-based reasoning to relation-based reasoning. Both still struggled with concepts in the course and did not achieve model-based reasoning during the ten weeks of the class.

KR, who came in with high prior knowledge, was also in first-year calculus and used relation-based thinking near the beginning of the term and was able to move to model-based thinking as he applied the concepts to the lab tasks.

MJ, who had low prior knowledge to begin with, was enrolled in second-year calculus. Like KR, she began the term using relation-based reasoning but soon employed model-based reasoning, as well as strong study skills to bring her knowledge up to the level she believed was required by the course.

TA and AK, who came in with high prior knowledge, were also in second-year calculus, and both used model-based reasoning from the beginning of the term.

Table 20: *Summary of level of reasoning related to mathematical experience and prior knowledge among the seven subjects.*

	Low prior knowledge	High prior knowledge
Below calculus	—	phenomenon-based (JF)
First year calculus	phenomenon-based to relation-based (AM, YZ)	relation-based to model-based (KR)
Second year calculus	relation-based to model-based (MJ)	model-based (AK, TA)

Gauging success of the subjects was more difficult, as the electrical knowledge survey was not a good measure of the subjects' ability to perform in class. However, based on the subjects' own verbal assessment of their success during observations and the final interview, their success at finishing the lab tasks, and their scores on the labs, the students could be tentatively sorted into three relative groups of low, moderate, and high success, as show in Table 21.

Subjects experiencing the highest self-perceived success were those with the highest math ability, regardless of prior knowledge. For those enrolled in first-year calculus, prior knowledge appeared to be the distinguishing factor between low and moderate success. For the one subject who had not yet reached the level of calculus, high prior knowledge was insufficient to help this subject achieve what he felt would be high success in the class.

Table 21: *Summary of success at lab tasks related to math ability and prior knowledge among the seven subjects.*

	Low prior knowledge	High prior knowledge
Below calculus	—	low success
First year calculus	low success	moderate success
Second year calculus	high success	high success

For these seven subjects, then, the tentative conclusions is that mathematical experience appeared to be as important as, or perhaps more important than, prior knowledge of electrical systems in promoting success in class. More work with a larger sample group, and use of a more definitive measure of “success,” would be necessary to state any further claims, but a prediction that could be derived from this might be that success in electrical engineering tasks requires the logic and mathematical ability that a student acquires in advanced calculus and higher mathematics courses.

Meaningful learning

At the start of the study, the researcher understood “meaningful learning” to be a body of knowledge that learners apply to a task spontaneously, and that as learners work on further related tasks, the body of meaningful knowledge grows. However, results emerging from this study suggest a different model.

Meaningful learning appeared to be highly situational. For each of the subjects in this study, the body of meaningful knowledge changed with the nature of each task and with the subjects' interpretation of the task. The body of meaningful knowledge could, in fact, change mid-task as the subject's understanding of the task changed, triggering the recall of some piece of knowledge that had not yet been employed. Meaningful learning, then, emerged among the seven subjects as that learning which is believed to be related to the task at hand, and appeared to be a flexible body of knowledge that changed in content rather than in size according to the demands of the task, though the size and appropriateness of each subject's meaningful knowledge may have been related to the extent of their prior knowledge. What triggers the movement of knowledge from the inert body to the meaningful body cannot be fully explained by this study, but the subjects in this study appeared to take cues from the lab instructions, the schematics, the teaching assistants, and each other.

The direct instruction that the students received during lecture appeared in their conversations about the lab tasks, either overtly as a student suddenly recalled a particular lecture point or consulted the class notes, or less obviously as the students applied Ohm's Law or other equations to the lab tasks. Prior knowledge also emerged during lab observations, sometimes in the form of "One time I..." stories about prior experiences with electrical circuits. For example, during a conversation that arose about the fuse in the multimeter, MJ related an experience with changing the fuses in her car and related the car's fuses to fuses in the circuit. JF drew on his experience in construction and

related stories about wiring that he had done that he thought had a relation to what he was doing in lab.

However, the body of meaningful learning that was applied was not always appropriate to the task, which highlighted the importance of student interpretation of the task. The first task in Section 2 of the lab manual (Lab 3) had subjects construct a circuit in which they measured the current and voltage in circuits that included the TekBot motor (Figure 37). Students were to measure current directly by using the multimeter as an ammeter and wiring it directly into the circuit in the first instance, then measure voltage by using the multimeter as a voltmeter and measuring voltage across a resistor in the second circuit, then use Ohm's Law to calculate current.

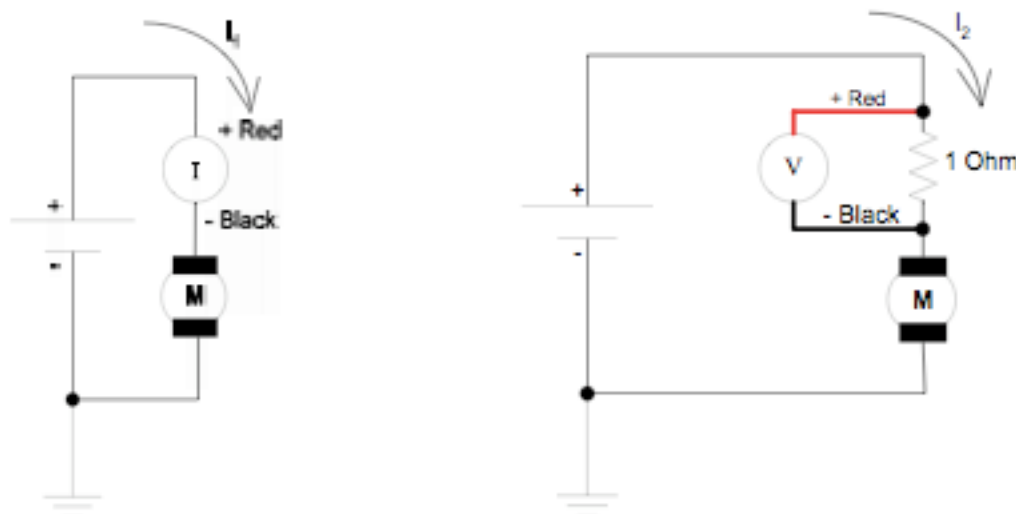

Figure 37: Schematics from Section 2 of the ECE 112 lab manual for an exercise in measuring current directly and indirectly.

When first encountering this problem, both JF and KR believed that the purpose of the exercise was to measure current with and without the load of the resistor, and both

applied prior knowledge of electrical circuits to predict that in the circuit with the resistor, the motor should slow down because of what they perceived as the extra load. Both discounted the resistance of the ammeter in the first circuit, and it wasn't until they read beyond the instructions for setting up the circuit that they realized that the problem was about something other than what they anticipated. Both required assistance from lab partners and the teaching assistants to understand the purpose of the exercise. Only when they understood the purpose were they able to draw on the necessary knowledge to complete the calculations associated with the exercise.

Revised model of task-based learning

As predicted in the proposed model, subjects in this study entered the class with a body of prior knowledge and continued to acquire knowledge during the lecture portion of the course. Some of that knowledge expressed initially, and some of the knowledge that was delivered in the lecture, emerged in discussions during lab as the students worked to solve the problems presented.

However, bodies of meaningful and inert knowledge do not remain static. At the same time that the subjects learned new knowledge in lecture, their knowledge changed during lab as they worked through problems and observed the effects of voltage, current, and resistance on various circuits. What knowledge emerged as meaningful changed as the context of each lab changed. Meaningful knowledge appeared to be highly situational,

and tied not only to the problems presented in the lab, but to the subjects' interpretation of those problems.

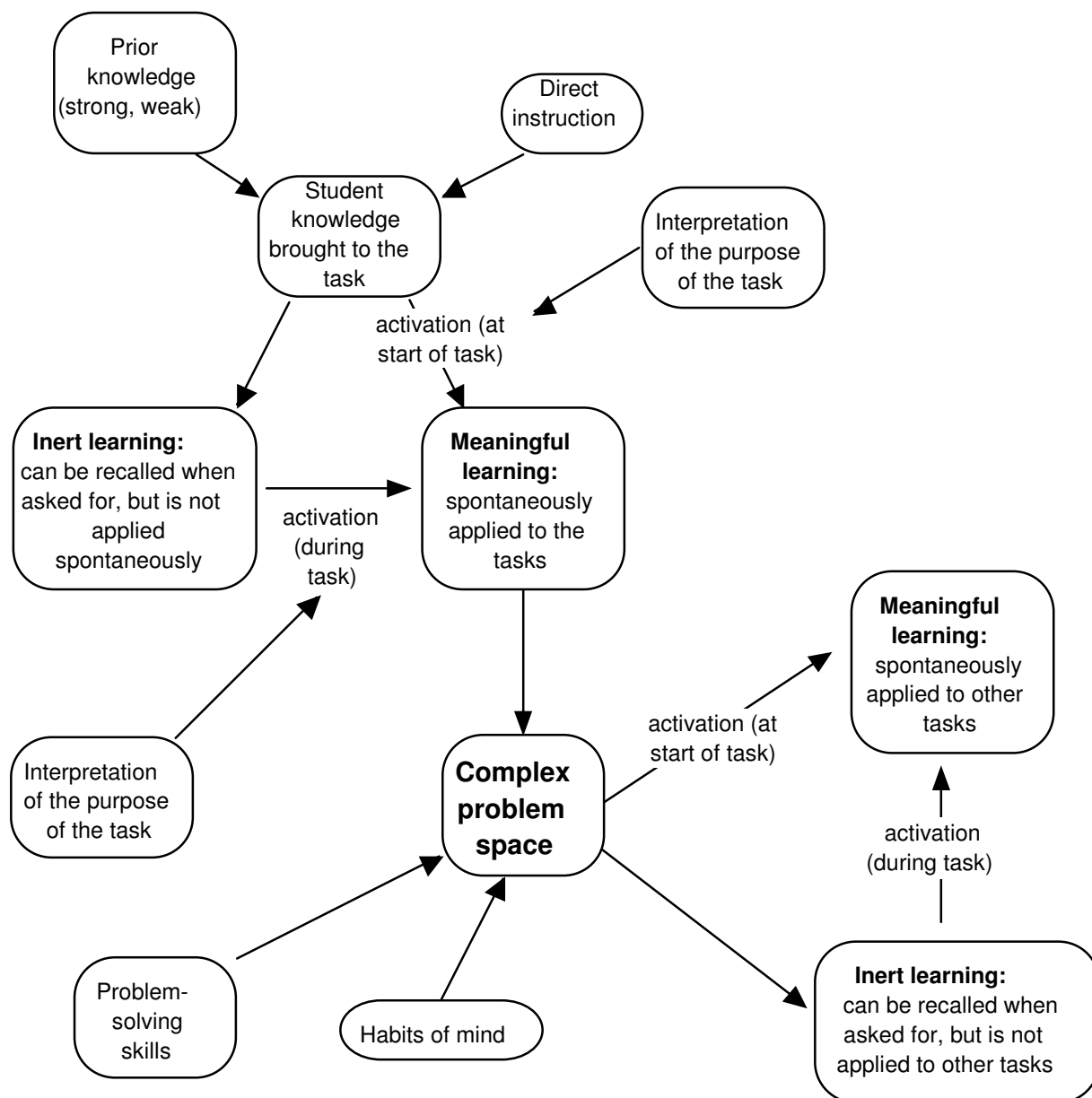

Figure 38: Revised model of task-based learning

One revision to the model is the influence of each student's idiosyncratic interpretation of the task. This appears to be the first cue that students draw up on when moving knowledge into a working set of facts and models that makes up meaningful knowledge. Interpretation also appears to be one trigger that activates inert knowledge during the task, if the student's interpretation of the task changes.

Also revised is an area that needs more work: the interface between meaningful and inert knowledge. Besides the student's interpretation of the task, what other triggers activate inert knowledge? How is further inert knowledge activated and made meaningful during the task, as a student suddenly recalls a key piece of information that he or she had not considered before? Why is knowledge that is meaningful in one setting left inert in a different yet similar setting? The considerable body of literature on transfer of knowledge will no doubt shed some light on this, yet it would be useful to consider this question in the context of task-based learning where students are presented with a series of different yet related tasks. It is probable that the students' interpretation of the purpose of the task enters into the activation process as the student decides, "What is to be done here, and what do I need to know in order to do it?"

Habits of mind emerged as students revealed their attitudes toward the course and approaches to learning. To reiterate earlier statements, habits of mind was not operationalized for this study. However, certain factors emerged in discussions with students that suggested this term needs to be unpacked and examined further. For example, both AM and MJ entered the course with little prior knowledge, but relatively high math ability. MJ was about a year ahead of AM in her math coursework, but AM

had more prior experience with electricity and electronics. Thus both appeared to be on equal footing as they began the course. Both spent the majority of their lab time on-task, working steadily on their lab assignments. However, conversations between the researcher and the subjects and conversations that the subjects held with their lab partners revealed some striking differences.

MJ's conversations were largely around the lab topics. She tended to work with a lab partner, and both she and her partner worked together as a team, rather than working on the same task side-by-side, to understand the concepts in lab and to apply concepts learned in class to lab. MJ frequently asked the teaching assistants for help or for confirmation of her ideas, and would continue the conversation with the teaching assistants, asking pertinent questions, until she was satisfied with her understanding. At the start of the term, feeling herself at a disadvantage because she had not taken ECE 111, MJ on her own volition purchased a kit for a circuit-building project that constituted the major project of the ECE 111 lab and carried out the activity on her own time. She used some of the time during the first observation to finish the project. She described re-doing some of the lab activities at home if she felt she had not fully understood them. In most cases when a lab offered optional activities for extra points, MJ completed these as time allowed, stating that she might as well to understand the concepts better. MJ appeared to be a highly motivated, highly self-directed learner with strong metacognitive skills that allowed her to assess herself for areas of self-perceived weakness. Her self-motivation led her to pursue activities that would correct her perceived weaknesses. In the end,

though MJ had not mastered all concepts that were assessed on the survey form, her score on the survey had improved, and she felt she had made significant progress.

AM's demonstrated a different set of attitudes and behaviors. AM and his partner worked together when the activities required them to, but separately when they did not, tending to work on the same task side-by-side while engaging in conversations about topics other than the task at hand. While AM asked the teaching assistants for help, he did so less frequently than MJ. Talk about the class that went on between AM and his partner was frequently negative, and AM appeared discouraged by the rigor of the course and his performance on exams. He did not discuss how he studied for the exams, so it was not possible to assess his study skills outside of class. In class, however, AM did no more than was required and left when he was finished. Each of the labs ended with an optional activity designed to reinforce learned concepts and to provide an opportunity to earn extra points. AM elected to do none of these, completing only the required tasks. At the end of the term, AM expressed a negative view of the class, but cited external factors, such as his views of the instructor's performance, as the cause of his difficulties.

The self-perceived success of these two students may have been related to their differing levels of math, but part may be attributable to their attitudes toward the course, the student skills demonstrated during the course, their locus of control, and their self-efficacy as engineering students. These factors were not measured directly during the course of the research, so conclusions around this must remain tentative, but these factors deserve more study as they be important factors to consider when planning task-based learning and evaluating its success.

Implications for future research

The results of this study have implications for future research related the learning of electrical concepts by engineering students, as well as research around task-based learning in general. This study uncovered possible links between reasoning, math ability, and success in a task-based electrical engineering course. It also contributed to an overall model of learning in a task-based setting.

Electrical engineering students who took part in this study demonstrated a wide range of prior knowledge, alternative conceptions, and mental models of circuit function. Though many of the students had been exposed to electrical concepts in prior courses, this was not universal, and therefore it cannot be assumed that students entering such courses will have a reasonably scientific understanding of voltage, current, resistance, and circuits. Furthermore, students entered with a wide range of prior mathematics experience, from algebra to advanced calculus, and while the mathematics required of students in the course were not above the algebraic level, those students who had higher mathematics ability, particularly those in second year calculus, appeared to be able to grapple with and reason about the course tasks with greater facility. Why that should be cannot be determined from the data in this study. More work will be necessary to determine the extent of the influence of prior math coursework and student success in first-year electrical engineering courses, and the interaction between prior knowledge,

mathematics ability, and reasoning. The results of such studies can inform instructors as they design activities and curriculum and determine prerequisites for their courses.

At a broader level, the model for task-based learning suggested in this study will need further work and refinement. The model forwarded in this study must, of necessity given the size of the study, be tentative. Factors entering the complex task space need to be examined in multiple settings to determine the full extent of interactions between them, particularly the interactions that produce the body of meaningful knowledge that a student applies to a task. The interaction between inert knowledge and meaningful knowledge is of particular interest: how is inert knowledge spontaneously activated? When a student has an incorrect understanding of a task, what is it that leads a student, without guidance from an instructor, to determine the actual intent of the task and to spontaneously form a new body of meaningful knowledge? What cues can an instructor provide to steer a student in the direction of the task's intent without providing a complete set of cookbook-like instructions?

Limitations

No research is ever perfect, and research that relies on subject's responses and researcher interpretation of those responses will have its limitations in terms of rigor of method and trustworthiness of the findings. This section discusses the limitations in this study and measures taken to constrain limitations.

Padgett (1998) describes six strategies for enhancing the rigor of a qualitative study: 1) prolonged engagement, 2) triangulation, 3) peer debriefing and support, 4) member

check, 5) negative case analysis, and 6) auditing. Four of these strategies were employed in this study.

The in-depth examination of the seven subjects allowed for prolonged engagement over the course of one term. A longer period of observation would have allowed for more description of the changing conceptions among the students, but would not have enhanced descriptions of the students' concepts during those ten weeks and their use of the concepts. Multiple observations that spanned lab time allowed for a multiple opportunities to observe students using their observations. One enhancement to prolonged engagement would have been to schedule more observations during the term. Another would have been to schedule post-observation interviews, which was among the original research plans. Neither of these proved to be practical for the researcher or the seven students. Furthermore, the quantity of data that could be extracted from the observations was uneven. Some observations were short, as the students finished their tasks early and left. Some students were more talkative and demonstrative than others, making interpretations of the less vocal students more difficult. Nor was it supposed that the students revealed their thinking completely through their thoughts and actions. As incomplete and uneven as the data sources must necessarily be, they still supplied a quantity of material for analysis and comparison with the interview data.

Triangulation was addressed through the use of multiple data sources, which were compared with one another while making interpretations regarding student concepts and reasoning. Multiple iterations through the data were also used as a form of triangulation by holding the prior interpretations in abeyance while making another pass through the

data, then comparing the results. After the data had been analyzed, the results were compared to existing literature on student concepts and reasoning with electrical circuits to find areas of agreement and negation. Post-observation interviews would have been useful here as well in providing another data source for comparison, particularly if students could have observed their own tapes and commented on their ideas and actions.

Negative case analysis is important when searching for patterns and trends. In this study, it was important to search for evidence that disconfirmed cases as well as that which confirmed cases. In searching for data indicating the quality of student reasoning, for example, it was critical to analyze all statements that aligned with the three levels of reasoning in order to determine each student's preferential mode of reasoning. Even after determining a preferential mode, it was necessary to review evidence for other types of reasoning and reanalyze the findings. There are few guidelines for this process in this type of study, and a more systematic method might have been devised and followed.

It was also critical to organizing the study and making the analysis transparent to readers to leave an audit trail. Every attempt was made in writing this report to describe the research methodology thoroughly and to give examples of student statements that support the findings. Nevertheless a single written report cannot describe every moment of the process, and choices had to be made about how to present the methods of analysis and how much of the data to present.

Peer debriefing and member checks were lacking from this study, and might have enhanced the analysis. The researcher had some opportunities to discuss the methods of the project with colleagues, but did not have a methodical plan for employing the support

and feedback of colleagues while carrying out the analysis. Therefore researcher bias could be a factor that affects the results of the study in spite of the researcher's efforts to remain objective. Member checks were planned initially, but did not prove practical, as the subjects in the study were less available by the time the data were analyzed. Had initial analysis taken place soon after the data collection concluded, it might have been possible to have the students comment on the initial interpretations, thus providing another check to researcher bias. During the study, demands of the subjects' academic schedules made post-observation interviews to much of a burden, and these were discarded from the research plans. Because member checks were not carried out, the conclusions in this study must be taken as the researcher's interpretation of the students' perspective. While every effort was made to allow the students' voices to prevail, it must be acknowledged that the researcher, too, has a perspective on the study that colors the findings.

Denzin and Lincoln (1994), in discussing trustworthiness of qualitative data, describe four factors to consider: credibility, transferability, dependability, and confirmability. All of these factors were taken into consideration to the degree possible within the framework of the study.

Credibility, or the confidence a reader may place in the findings, is established through multiple means. In this study, the primary means of establishing credibility were through triangulation, negative case analysis, and transparency of the analytical process. Transcription of the interviews and critical portions of the observations was time-consuming, as were the multiple reviews of the transcribed data and the videos

themselves. The degree to which the analysis can be presented in a written study limits the credibility, though ever effort was made to thoroughly document the analysis. One enhancement to credibility would have been member checks, which would have helped reduce the possibility of researcher bias in the interpretations of student statements.

Transferability refers to the degree to which other researchers can apply the findings of this study to their own. Here a thick description of the data, analysis, and findings are critical, and every attempt was made to provide sufficient description within the constraints of the report. Nevertheless, transferability relies in large part on the degree of congruence between the contexts being compared.

Dependability is determined by the stability of the findings over time and the internal coherence of the data relative to the findings and interpretations drawn in the study. A rich description of the data and analysis, providing an audit trail, was used to address dependability. A comparison of the findings in this study to existing literature provided a small measure of dependability. Peer evaluation would have enhanced this process by providing one or more external auditors to follow the analysis process and determine if they reached the same or similar conclusions. The thick descriptions within the study do provide the reader with an audit trail such that the reader may judge the dependability of the findings in this study.

References

- Albanese, M.A. & Mitchell, S. (1993) Problem-based learning: a review of literature on its outcomes and implementation issues. *Academic medicine*, 68(1), 52-81.
- Anderson, J.R. (1987). Skill acquisition: Compilation of weak-method problem solutions. *Psychological Review*, 94, 192-210.
- Bédard, D., Tardif, J., & Meilleur, L. (1996). *Evolution of students' reasoning skills on a two year basis in a PBL curriculum in medicine*. Paper presented at the Annual Meeting of the American Educational Research Association (New York, NY, April 8-12).
- Bliss, J., & Ogborn, J. (1985). Children's choices of uses of energy. *European Journal of Science Education*, 7(2), 195-203.
- Bransford, J.D., Goldman, S.R., Hasselbring, T.S., Pellegrino, J.W., Williams, S.M., & Vye, N. (1993). The Jasper Series: theoretical foundations and data on problem solving and transfer. In: Penner, L.A., Batsche, G.M., Knoff, H.W., & Nelson, D.L., eds. *The challenge in mathematics and science education: psychology's response*. Washington, D.C.: American Psychological Association.
- Breton, G. (1999). Some empirical evidence on the superiority of the problem-based learning (PBL) method. *Accounting Education*, 8(1), 1-12.
- Butts, W. (1985). Children's understanding of electric current in three countries. *Research in Science Education*, 15, 127-30.
- Chi, M.T.H. (1992). Conceptual change within and across ontological categories: Examples from learning and discovery in science. In Giere, R.N., ed. *Cognitive Models of Science: Minnesota studies in the philosophy of science* (pp. 129 - 186). Minneapolis: University of Minnesota Press.
- Chi, M.T.H., Bassok, M., Lewis, M.W., Reimann, P., & Glaser, R. (1989). Self-explanations: How students study and use examples in learning to solve problems. *Cognitive Science*, 13, 145-182.
- Cohen, R., Eylon, B., & Ganiel, G. (1983). Potential difference and current in simple electric circuits: A study of students' concepts. *American Journal of Physics*, 51(5), 407-412.
- Craik, K. (1943). *The Nature of Explanation*. Cambridge, MA: Cambridge University Press.

- Denzin, N.K. & Lincoln, Y.S. (1994). Entering the field of qualitative research. In N.K. Denzin & Y.S. Lincoln (Eds.), *Handbook of qualitative research* (pp. 1-17). Thousand Oaks, CA: Sage.
- diSessa, A. A. (1982). Unlearning Aristotelian physics: A study of knowledge-based learning. *Cognitive Science*, 6, 37-75.
- diSessa, A., Sherin, B. (1998). What changes in conceptual change? *International Journal of Science Education*, 20, 1155-1191.
- Driver, R., Leach, J., Millar, R., Mortimer, E., & Scott, P. (1996). *Young People's Images of Science*. Buckingham; Open University Press.
- Dupin, J. & Johsua, S. (1987). Conceptions of French pupils concerning electric circuits: structure and evolution. *Journal of Research in Science Education*, 24(9), 791-806.
- Ebenezer, J.V., & Fraser, D.M. (2001). First year chemical engineering students' conceptions of energy in solution processes: Phenomenographic categories for common knowledge construction. *Science Education*, 85, 509-535.
- Enarson, C., & Cariaga-Lo, L. (2001). Influence of curriculum type on student performance in the United States Medical Licensing Examination Step 1 and Step 2 exams: Problem-based learning vs. lecture-based curriculum. *Medical Education*, 35, 1050-1055.
- Gunstone, R.F., Gray, C.M.R., Searle, P. (1992). Some long-term effects of uninformed conceptual change. *Science Education*, 76(2), 175-197.
- Härtel, H. (1985). The electric voltage. In Walters, R.D. & Rhöneck, C. (eds), *Aspects of Understanding electricity: Proceedings of an International Workshop*. Ludwigsburg: Institut für der Naturwissenschaften and der Universität Kiel.
- Hmelo, C.E. (1998) Problem-based learning: Effects on the early acquisition of cognitive skill in medicine. *The Journal of the Learning Sciences*, 7, 173-208.
- Husserl, E. (1913). *Ideas: general introduction to pure phenomenology*. Translated 1958 by W.R. Gibson. London: George Aleln and Unwin.
- Johnson-Laird, P.N. (1983). *Mental Models*. Cambridge, MA: Harvard University Press.
- Kawasaki, K., Herrenkohl, L.R., & Yeary, S.A. (2004). Theory building and modeling in a sinking and floating unit: a case study of third and fourth grade students' developing epistemologies of science. *International Journal of Science Education*, 26(11), 1299-1324.

- Lawson, A.E., Baker, W.P., DiDonato, L., & Verdi, M.P. (1993). The role of hypothetico-deductive reasoning and physical analogues of molecular interactions in conceptual change. *Journal of Research in Science Teaching*, 30(9), 1073-1085.
- Lee, M.H. (1999). On models, modeling, and the distinctive nature of model-based reasoning. *AI Communications*, 12, 127-137.
- Leite, L., & Afonso, A. (2004). Forms of reasoning used by prospective physical science teachers when explaining and predicting natural phenomena: The case of air pressure. *Canadian Journal of Science, Mathematics, and Technology Education*, 4(2), 169-191.
- Lincoln, Y. (1990). Toward a categorical imperative for qualitative research. In Eisner, E.W. & Peshkin, A. (Eds). *Qualitative Inquiry in Education: The Continuing Debate*. New York and London: Teachers College Press.
- Linder C.J. (1993). A challenge to conceptual change. *Science Education*, 77(3), 293-300.
- Liu, X., & Tang, L. (2004). The progression of students' conceptions of energy: A cross-grade, cross-cultural study. *Canadian Journal of Science, Mathematics, & Teaching Education*, 4(1), 43-57.
- Liu, X., Ebenezer, J., & Fraser, D.M. (2002). Structural characteristics of university engineering students' conceptions of energy. *Journal of Research in Science Teaching*, 39(5), 423-441.
- Marton, F. (1981). Phenomenography — describing conceptions of the world around us. *Instructional Science*, 10, 177-200.
- Marton, F., & Booth, S. (1997). *Learning and awareness*. Mahwah, NJ: Erlbaum.
- Mazur, E. (1997). *Peer Instruction: A User's Manual*. Upper Saddle River, N.J.: Prentice Hall.
- McCloskey, M.E. & Glucksberg, S. (1978). Natural categories: Well defined or fuzzy sets? *Memory & Cognition*, 6(4), 462-472.
- McDermott, L.C. & van Zee, E.H. (1985). Identifying and addressing student difficulties with electric circuits. In Walters, R.D. & Rhöneck, C. (eds), *Aspects of Understanding electricity: Proceedings of an International Workshop*. Ludwigsburg: Institut für der Naturwissenschaften and der Universität Kiel.

- Moustakas, C (1994). *Phenomenological Research Methods*. Thousand Oaks, CA. : Sage Publishing.
- Nersessian, N.J. (1998). Model-based reasoning in conceptual change. In Magnani, L. & Nersessian (ed.), N.J. *Model-Based Reasoning in Scientific Discovery* (pp. 5-22). New York: Kluwer Academic.
- Nersessian, N.J. (1992). How do scientists think? Capturing the dynamics of conceptual change in science. In Giere, R. (ed.), *Cognitive Models of Science, Minnesota Studies in the Philosophy of Science, 15* (pp. 3-44). Minneapolis: University of Minnesota Press.
- Osborne, R. (1981). Children's ideas about electrical current. *New Zealand Science Teacher*, 29(1), 12-19.
- Osborne, R., & Freyberg, P. (1985). *Learning in science: the implications of children's science*. Auckland and London: Heinemann.
- Padgett D.K. (1998). *Qualitative methods in social work research: challenges and rewards*. Thousand Oaks, CA: Sage.
- Pardhan, H. & Bano, Y. (2001). Science teachers' alternate conceptions about direct-currents. *International Journal of Science Education*, 23(3), 301-318.
- Patton, M.Q. (2002). *Qualitative Research & Evaluation Methods*, 3rd edition. Thousand Oaks, CA: Sage Publications.
- Posner, G.J., Strike, K.A., Hewson, P.W., Gertzog, W.A. (1982). Accomodation of a scientific conception: Toward a theory of conceptual change. *Science Education*, 66(2), 211-227.
- Psillos, D. Koumaras, P., & Tiberghien, A. (1988). Voltage presented as a primary concept in an introductory teaching sequence on DC circuits. *International Journal of Science Education*, 10(1), 29-43.
- Rosch, E.H. (1973). Natural categories. *Cognitive Psychology*, 4, 328-350.
- Roth, W.M. 2005. *Doing Qualitative Research: Praxis of Method*. Rotterdam & Taipei: Sense Publishers.
- Samarapungavan, A., & Wiers, R. (1997). Children's thoughts on the origin of species: a study of explanatory coherence. *Cognitive Science*, 21(2), 147-178.

- Saunders, K., McIntosh, J., McPherson, J., & Engel, C.E. (1990). A comparison between University of Newcastle and University of Sydney final-year students: Knowledge and competence. In Noonan, Z.M., Schmidt, H.G., & Ezzat, E.S. (eds), *Innovation in medical education: An evaluation of its present status*. New York: Springer Publishing Company.
- Schauble, L., Glaser, R., Raghavan, K., & Reiner, M. (1991). Causal models and experimentation strategies in scientific reasoning. *The Journal of the Learning Sciences*, 1(2), 201-238.
- Sherin, B., Edelson, D., & Brown, M. (2004). On the content of task-structured science curricula. In: Flick, L.B. & Lederman, N.L. *Scientific Inquiry and Nature of Science: Implications for Teaching, Learning, and Teacher Education*. Dordrecht, the Netherlands: Kluwer Academic Publishers
- Shipstone, D (1985). *Electricity in simple circuits*. In Driver, R., Guesne, E., & Tiberghien, A. (eds), *Children's Ideas in Science*, Milton Keynes: Open University Press, pp 33-51.
- Stockmayer, S.M. & Treagust, D.F. (1996). Images of electricity: how do novices and experts model electric current? *International Journal of Science Education*, 18(2), 163-178.
- Trumper, R. (1998). A longitudinal study of physics students' conceptions on energy in pre-service training for high school teachers. *Journal of Science Education and Technology*, 7(4), 311-318.
- Trumper, R. Raviolo, A., & Shnersch, A.M. (2000). A cross-cultural survey of conceptions of energy among elementary school teachers in training — empirical results from Israel and Argentina. *Teaching and Teacher Education*, 16, 697-714.
- Vandierendonck, A. & de Vooght, G. (1996). Evidence for mental-model-based reasoning: A comparison of reasoning with time and space concepts. *Thinking and Reasoning*, 2(4), 249-272.
- Vernon, D.T.A. & Blake, R.L. (1993) Does problem-based learning work? A meta-analysis of evaluative research. *Academic Medicine* 68(7)550-563.
- Vosniadu, S., & Brewer, W.F. (1992). Mental models of the earth: A study of conceptual change in childhood. *Cognitive Psychology*, 24, 535-585.
- Vygotsky, L. (1968). *Mind in society: The development of higher psychological processes*. Cambridge, MA: Harvard University Press.

- Wandersee, J.H., Mintzes, J., & Novak, J. (1994). Research on alternative conceptions in science. In D. Gabel (Ed.), *Handbook of research on science teaching and learning*. New York: MacMillan.
- Watts, D.M. (1983). Some alternative views of energy. *Physics Education*, 18, 213-217.
- Westbrook, S., Rogers, L.N., & Marek, E.A. (1990). *An analysis of the relationships of formal reasoning, science process skills, gender, and instructional treatment to conceptual shifts in tenth grade biology students*. Paper presented at the National Association for Research in Science Teaching conference, Atlanta, GA, April 11, 1990.
- Weinstein, M. (2005) TAMS Analyzer (Version 3.3) [Computer software and manual]. Retrieved from <http://tamsys.sourceforge.net>
- Whitehead, A.N. (1929). *The aims of education & other essays*. New York: MacMillan.

Appendix: Electrical Concepts Inventory

This survey was developed by the author as a means of establishing the overall range of knowledge of basic electrical concepts among electrical engineering students. Students from the class who volunteered for the study were sorted according to whether they fell at the high end or low end of the range. The same survey was administered with a different cover sheet at the end of the term. The cover sheet on the post survey omitted the demographic questions and asked about the highest level of math that the students had taken, as the researcher and the instructor suspected that math ability may have an influence on student performance in the course.

Name: _____

Electrical Concepts Survey

Instructions:

Please read each of the questions carefully. Choose the response that you believe is the best answer, then use the space provided to write why you believe this is the best answer. The purpose of this survey is to discover what you understand right now about electrical concepts, so please choose the answer that fits best with your understanding.

This inventory will take approximately 30 minutes to complete.

Section 1: Personal data

What is your age? _____

Male or female? _____

How would you describe your race/ethnic group? _____

To the best of your knowledge, list classes (if any) that you took in middle school (or junior high), high school, and college, in which you learned about electrical concepts:

Do you “tinker” with electronics at home, such as building computers or pulling electrical devices apart to see how they work? If so, please describe:

Section 2: Electrical concepts

1. Suppose you were given the following items:

a small light bulb 

a dry cell (battery) 

some wire 

In the space below, sketch how you could use these items to make the light bulb light up. Assume you can use as many of the items above as are necessary.

Explain how your the arrangement in your diagram works, including what it is that makes the light bulb light up.

2. Observe the three diagrams of electrical circuits below. Each circuit contains a dry cell and one or more bulbs:

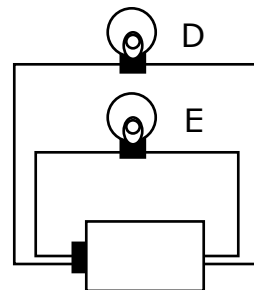
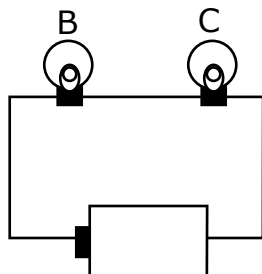
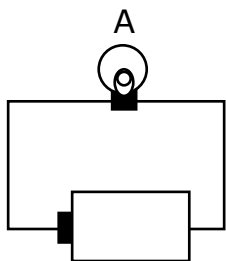

In each set of statements below, circle the one that you think is true, and explain why in the space beneath. If none of the statements seem true to you, explain why.

a. B is brighter than C

C is brighter than B

B and C are equally bright

b. D is brighter than E

E is brighter than D

D and E are equally bright

c. A is brighter than B

B is brighter than A

A and B are equally bright

d. A is brighter than D

D is brighter than A

A and D are equally bright

3. Observe the circuit below, which contains a dry cell and three bulbs:

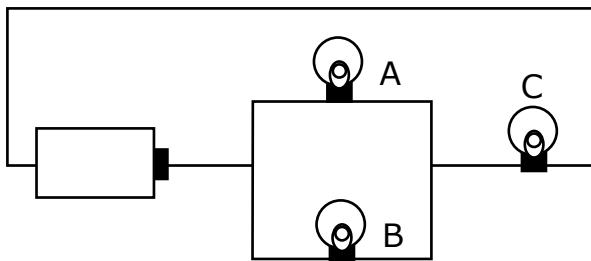

In each set of statements below, circle the one that you think is true, and explain why in the space beneath. If none of the statements seem true to you, explain why.

a. A is brighter than B B is brighter than A both A and B are equally bright

b. A is brighter than C C is brighter than A both A and C are equally bright

4. Observe the circuit below, which includes a dry cell, two bulbs, and a switch:

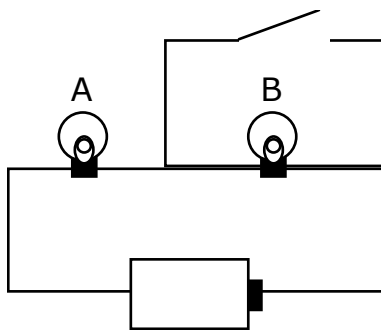

Circle as many of the following that will happen when the switch is closed, and explain in the space below:

A will get brighter A will get dimmer or go out B will get brighter B will get dimmer or go out

5. Observe the circuit below. This circuit contains a dry cell, a bulb, and two resistors (R_1 and R_2).

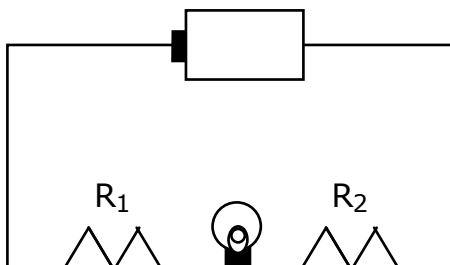

Predict and explain the change in brightness, if any, of the bulb in each of these situations:

a. If R_1 is increased the bulb will:
 get brighter get dimmer stay the same

c. If R_2 is increased the bulb will:
 get brighter get dimmer stay the same

6. Observe the circuit below. This circuit contains two bulbs, two dry cells, and a switch.

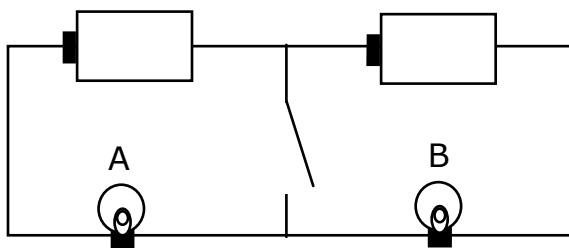

Check off the most accurate prediction what will happen when the switch is closed (choose 1), and in the space at the right, explain your choice:

- both bulbs go out
- A becomes brighter
- B becomes brighter
- B becomes dimmer
- A becomes dimmer
- Some combination of the the above
- Nothing will change

7. Observe the circuit below, which contains a dry cell, two resistors (R_1 and R_2) and two voltmeters (V_1 and V_2):

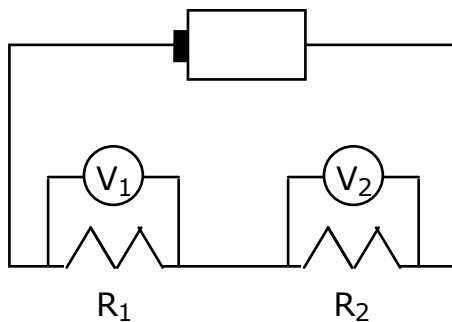

If R_2 is increased, which of the following will happen? Circle the statements that best describe what will happen to V_1 and V_2 .

V_1 will increase

V_1 will decrease

V_1 will stay the same

V_2 will increase

V_2 will decrease

V_2 will stay the same

In the space below, explain your answer: